



HUMAN CAPITAL  
NATIONAL COHESION STRATEGY



Wrocław University of Technology

EUROPEAN UNION  
EUROPEAN  
SOCIAL FUND



THE DEVELOPMENT OF THE POTENTIAL AND ACADEMIC PROGRAMMES OF WROCLAW UNIVERSITY OF TECHNOLOGY

BOGDAN MIEDZIŃSKI,  
GRZEGORZ WIŚNIEWSKI, MARCIN HABRYCH

# FIBER OPTICS LAB

TEXT BOOK

WROCLAW UNIVERSITY OF TECHNOLOGY

WROCLAW, 2010

**THE DEVELOPMENT OF THE POTENTIAL AND ACADEMIC PROGRAMMES OF WROCLAW UNIVERSITY OF TECHNOLOGY**

**CONTENTS**

MEASUREMENT OF ATTENUATION OF A MULTISEGMENT FIBER OPTICS TRANSMISSION SYSTEM.....	4
1. Introduction.....	4
2. Measurement of attenuation.....	8
2.1. Investigations for different type of the fiber guide.....	8
2.2. Investigations of the attenuation value for the introduces connector .....	9
2.3. Measurement for different length of the fiber guide .....	10
2.4. Investigation of attenuation for the fixed multisegment system.....	12
2.5. Testing of variation of the fiber attenuation for simple and multisegment transmission path.....	14
ATTENUATION MEASUREMENT OF OPTICAL FIBER GUIDES .....	16
1. Introduction.....	16
2. Investigation of attenuation of the fiber guide .....	17
2.1. Measuring arrangement and procedure .....	18
2.1.1 Derivation of the light source characteristics.....	19
2.1.2 Frequency characteristic of the light detector .....	20
2.1.3 Derivation of the fiber guide characteristic .....	22
TESTING OF OPTICAL POLARIZER .....	25
1. Introduction.....	25
2. Testing stand and measuring procedure.....	27
2.1. Procedure of testing .....	29
3. Results of investigations- tables: .....	29
INVESTIGATION OF RADIATION ANGULAR CHARADCTERISTICS OF SEMICONDUCTOR LASERS.....	31
1. Introduction.....	31
2. Investigation of radiation characteristics of semiconductor laser.....	33
2.1. Testing procedure .....	34
INVESTIGATION OF OUTPUT SPECTRUM AND LIGHT-CURRENT CHARACTERISTICS OF OPTICAL LIGHT SOURCE.....	38
1. Introduction .....	38
2. Testing arrangement .....	42



**THE DEVELOPMENT OF THE POTENTIAL AND ACADEMIC PROGRAMMES OF WROCLAW UNIVERSITY OF TECHNOLOGY**

2.1. Testing procedure .....	43
INVESTIGATION OF MATCHING EFFICIENCY OF OPTICAL CONNECTORS.....	46
1. Introduction .....	46
2. Investigations of the matching efficiency .....	48
2.1. Testing procedure .....	48
References .....	51

## TASK No 1

# MEASUREMENT OF ATTENUATION OF A MULTISEGMENT FIBER OPTICS TRANSMISSION SYSTEM

Concise specification (manual)

## 1. Introduction

Due to numerous advantages like: immunity to interference and crosstalk, enormous potential bandwidth, electrical isolation, low transmission loss, high reliability and low cost the optical fiber communication replaces traditional coaxial cables, upgrade the data rate and save space at the same time.

The simple optical transmission path composed of a transmitter, receiver and fiber guide is presented in Fig. 1.1.

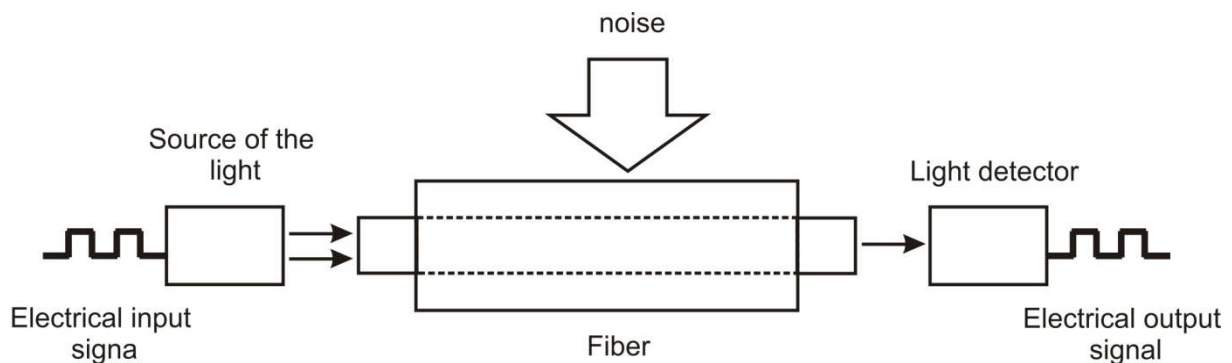

Fig.1.1 Simplified diagram of fiber transmission

However one has to know that the fiber transmission systems are not ideal and that both dispersion and power losses are unavoidable. The power losses are the most critical when launch the light ray into the fiber and at any other coupling elements being used. Therefore, they are increased with the fiber waveguide length as well as with number of various passive components being employed.

If about number of modes being conducted there are distinguished two basic types of fiber: single (SMF) and multimode (MMF) respectively. However when consider the refractive index distribution there are: step index fiber and graded index fiber.

Single-mode fiber provides much higher transmission bit rate due to decreased attenuation and dispersion values, therefore its bandwidth – length product is over 1GHz km.

**THE DEVELOPMENT OF THE POTENTIAL AND ACADEMIC PROGRAMMES OF WROCLAW UNIVERSITY OF TECHNOLOGY**

Its diameter is also smaller (even below 1  $\mu\text{m}$ ) therefore, due to decreased NA value (below 0.1) the application of channel couplers are necessary to decrease the coupling losses.

Multi-mode fiber conducts great amount of the modes simultaneously (number of modes can reach even a few thousands) what result in the basic mode distortion due to mutual transfer of energy from higher order modes to the fundamental one. Therefore, it is used for short haul with medium bit rate. The fiber size is much higher with compare to the SMF. However, the numerical aperture (NA) is increased what makes the coupling more effective. Comparison of size as well as distribution of the refraction index for different fiber guides are presented for example in Fig. 1.2.

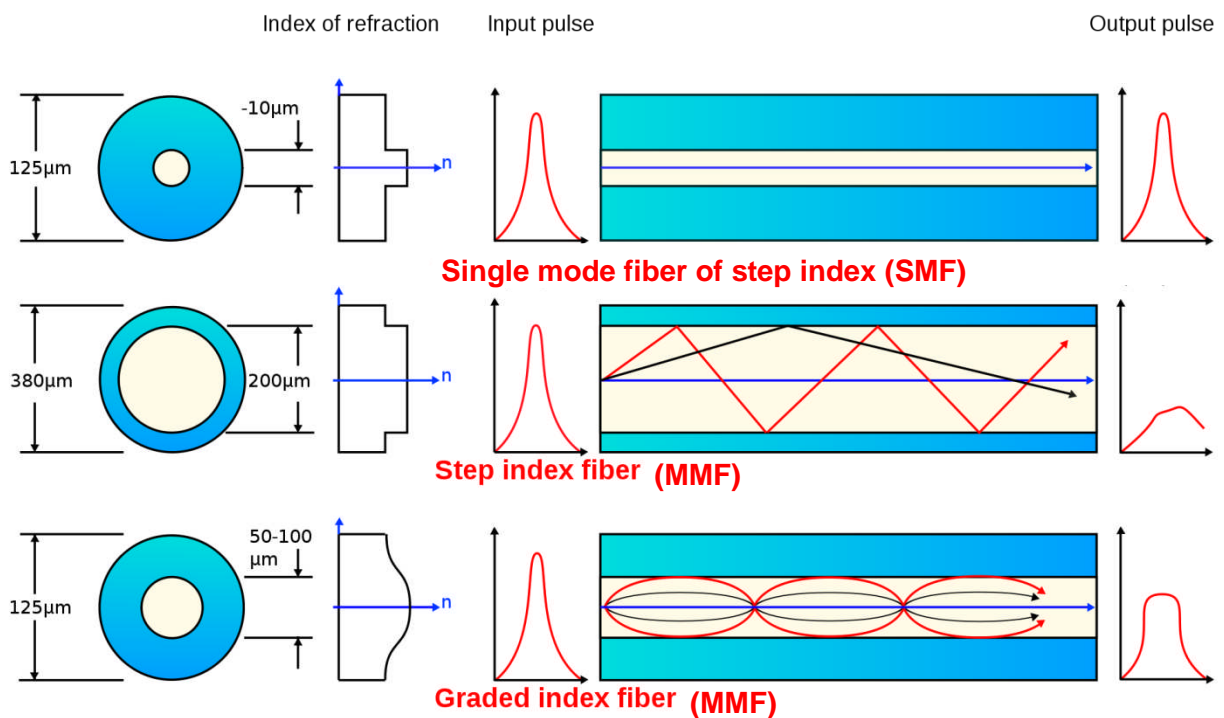

Fig. 1.2 Comparison of optical fiber guide types

Fiber loss is wavelength-dependent. It is divided into two basic groups: inherent (intrinsic) and induced (introduced) losses. These due to the intrinsic reasons are presented for example in Fig 1.3.



**THE DEVELOPMENT OF THE POTENTIAL AND ACADEMIC PROGRAMMES OF WROCLAW UNIVERSITY OF TECHNOLOGY**

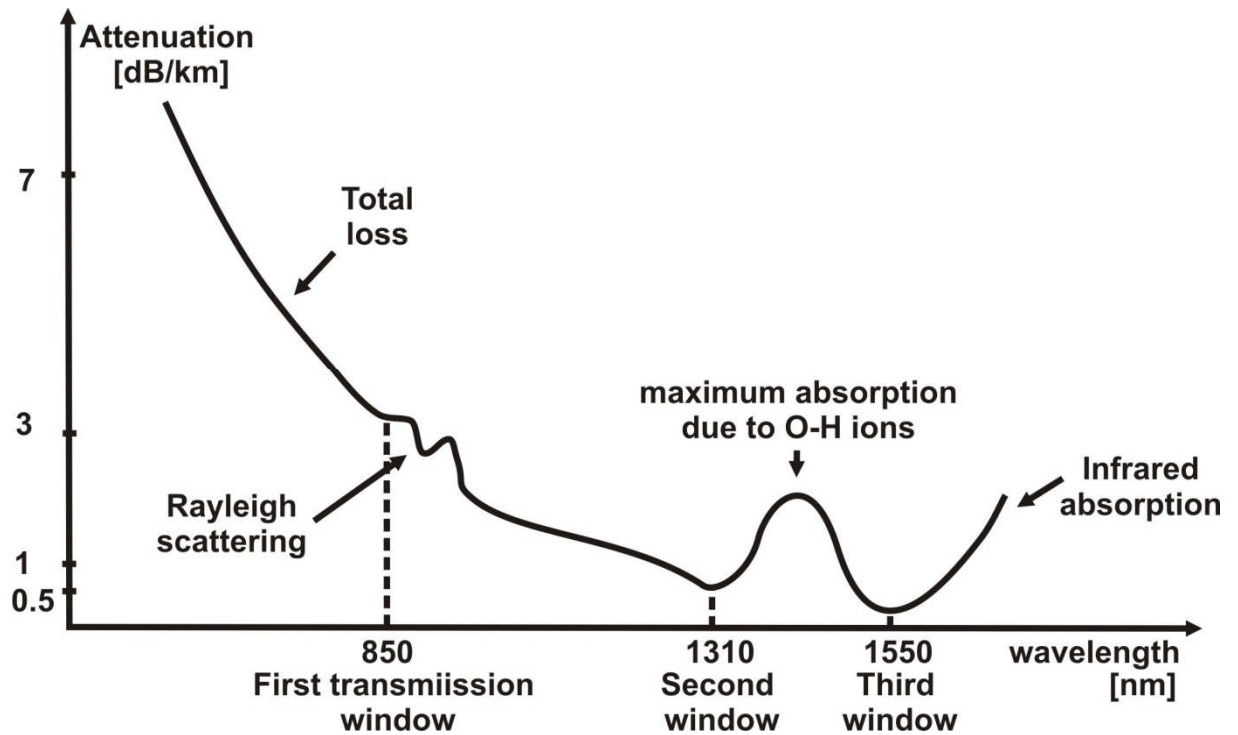

Fig. 1.3 The attenuation spectra for the intrinsic loss for selected fiber guide

Power losses are expressed in decibels as follows:

Number of decibels:

$$dB = 10 \log \frac{P_{out}}{P_{in}} \tag{1}$$

Where:

$P_{in}$  - optical power at input,

$P_{out}$  - optical power at output,

$P_{out}$  and  $P_{in}$  has to be expressed both at the same quantities like [mW], [W] etc.

3dB – corresponds to 50%,

20dB – to 1%,

30dB – to 0.1%,

40dB – to 0.01%, etc.



**THE DEVELOPMENT OF THE POTENTIAL AND ACADEMIC PROGRAMMES OF WROCLAW UNIVERSITY OF TECHNOLOGY**

However, attenuation for the fiber guide is expressed as losses per unit length of fiber:

$$\alpha = \frac{1}{L} 10 \log \frac{P_{out}}{P_{in}} \tag{2}$$

where:

L – fiber length.

Note that attenuation expressed in decibels per km is not absolute. The absolute value (expressed in [dBm]) is equal to the logarithm of the ratio of measure output power with respect to input reference, equal to 1 [mW].

$$\alpha [dBm] = 10 \log \frac{P_{out}}{1[mW]} \tag{3}$$

where:

10 [mW] corresponds to 10 [dBm];

1.0 [mW] corresponds to 0 [dBm];

0.1 [mW] corresponds to -10 [dBm].

Thus the output power of 100mW converted to dBm is equal:

$$\alpha [dBm] = 10 \log \frac{P_{out}}{1[mW]} = 10 \log \frac{100[mW]}{1[mW]} = 10 \cdot \log(100) = 10 \cdot 2 = 20 [dBm] \tag{4}$$

If about the induced fiber losses the geometrical effect and excessive bending of the fiber guide play important role. The bending losses principle is shown in Fig. 1.4

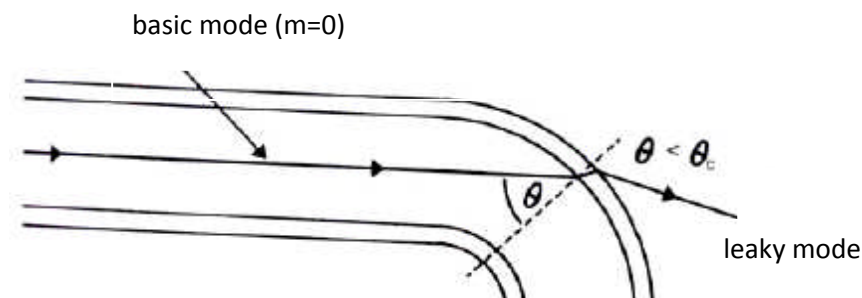

Fig. 1.4 Bending losses ( $\theta_c$  – critical angle)

**THE DEVELOPMENT OF THE POTENTIAL AND ACADEMIC PROGRAMMES OF WROCLAW UNIVERSITY OF TECHNOLOGY**

## 2. Measurement of attenuation

All investigations shall be carried out using the same testing arrangement as indicated in Fig 2.1 The test includes following attenuation measurements:

- simple transmission system for two selected different type of the fiber guide.
- system with introduced the fiber guides interconnector
- transmission system of different length for the fiber string
- multisegment transmission path.

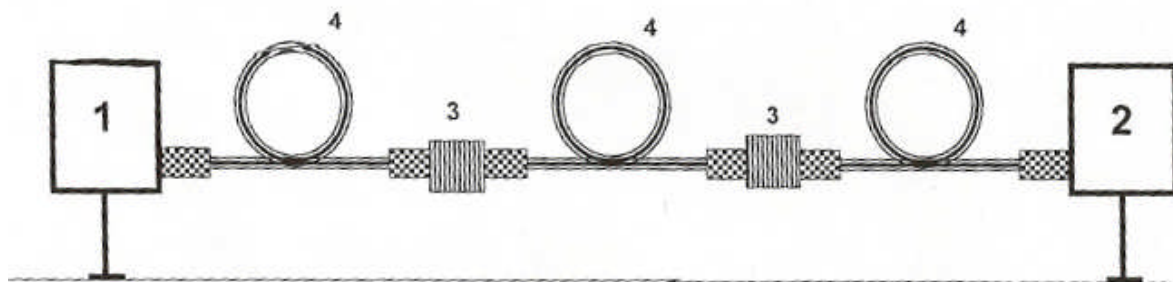

Fig. 2.1. Schematic diagram of the measuring arrangement (1. Light source / source of optical power (FLS-300); 2. Optical power detector (FPM-300) 3. Adapter ST/ST 4. Patchcord ST/ST (standard optical cable)

### 2.1. Investigations for different type of the fiber guide

The test performs for two selected fiber strings (denoted as blue and orange fiber respectively) using the wave-length equal to 850nm and 1300nm at different level of the input light power. Set-up the circuit as illustrated in Fig 2.2 using the light source (FLS – 300 type) and the power-meter (FPM-300 type) as the transmitter and receiver respectively.



**THE DEVELOPMENT OF THE POTENTIAL AND ACADEMIC PROGRAMMES OF WROCLAW UNIVERSITY OF TECHNOLOGY**

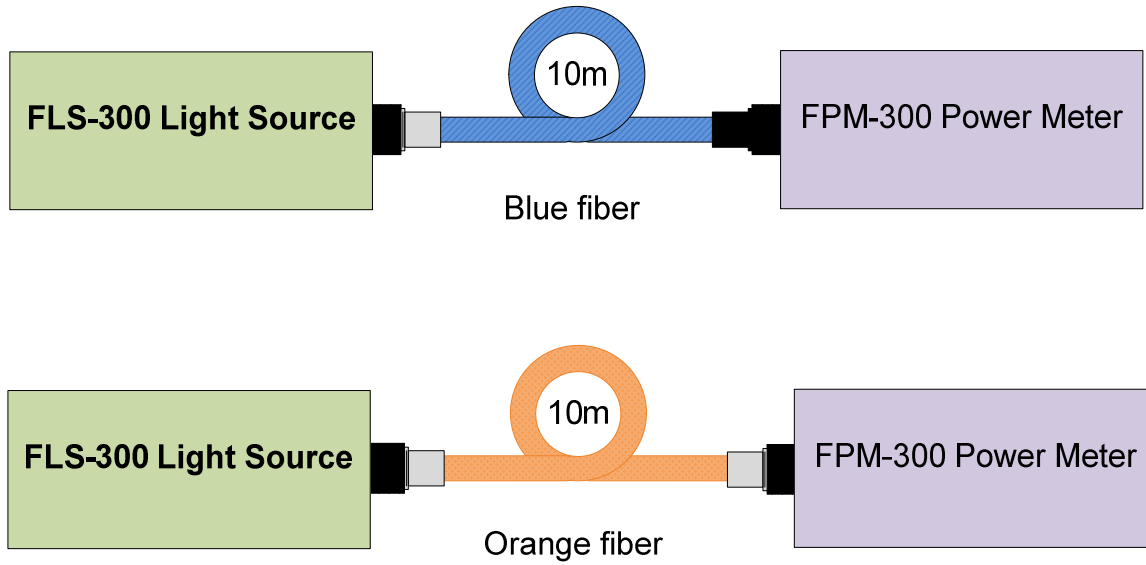

Fig. 2.2 Set-up for testing of the fiber string attenuation

Measure both the input and output power for different input level selected both automatically and manually and calculate the attenuation losses. All investigated results set-up in Table 2.1 and draw respective conclusions.

Table 2.1. Results of measurements of attenuation for different fiber guides (10m)

Lp.	Blue/Orange fiber					
	Wavelengths	Power (input) source	Power value	Power value	Loss in [dB], while reference power value from source in [dBm]	
	$\lambda$ [nm]	$P_{S1}$ [dBm]	$P_{dBm}$ [dBm]	$P_{nW}$ [nW]	$\alpha$ [dB]	$P_{S2}$ [dBm]
1	850					
2	1300					

**2.2. Investigations of the attenuation value for the introduces connector**

Perform testing for the transmission system with introduced connectors (ST/ST) in the circuit as shown in Fig. 2.3. Repeat measurements (5-times) after each connection and following disconnection of the two type connector equal to 850nm and 1300nm and list the results in Table 2.2. On the basis of the results formulate the conclusions.

**THE DEVELOPMENT OF THE POTENTIAL AND ACADEMIC PROGRAMMES OF WROCLAW UNIVERSITY OF TECHNOLOGY**

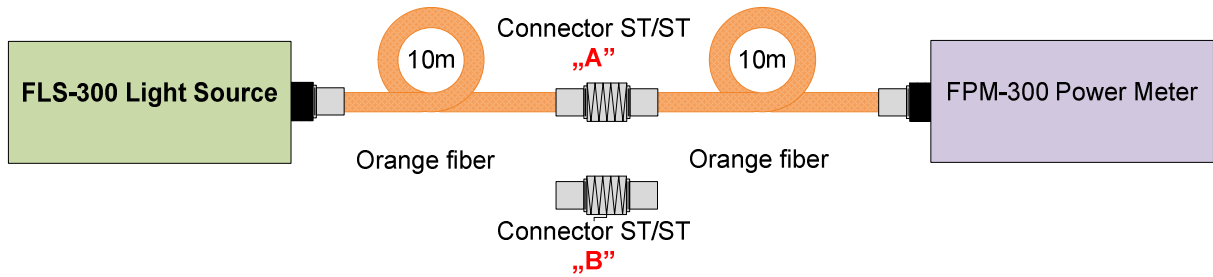

Fig.2.3 Set-up for testing of the influence of the connector

Table 2.2 Testing results of the influence of connector

Connector	Wavelength	Input power	Power value	Loss in [dB], while reference power value from source in [dBm]	
				$\alpha$ [dB]	$P_s$ [dBm]
Lp.	$\lambda$ [nm]	$P_{dBm}$ [dBm]	$P_{nW}$ [nW]		
1	850				
	1300				
2	850				
	1300				
3	850				
	1300				
4	850				
	1300				
5	850				
	1300				
	1300				
Average value	850				
	1300				

**2.3. Measurement for different length of the fiber guide**

Set-up the testing circuit as in Fig 2.4. Perform measurements for wavelength adjusted to 850nm and 1300nm while, changing the fiber length in the range 3, 5, 10, 15, 50 and 100 meters respectively. The results list into Table 2.3 and plot the power loss – length dependence. Compare the obtained results with the reference data (given in Fig 2.5 for blue fiber).



**THE DEVELOPMENT OF THE POTENTIAL AND ACADEMIC PROGRAMMES OF WROCLAW UNIVERSITY OF TECHNOLOGY**

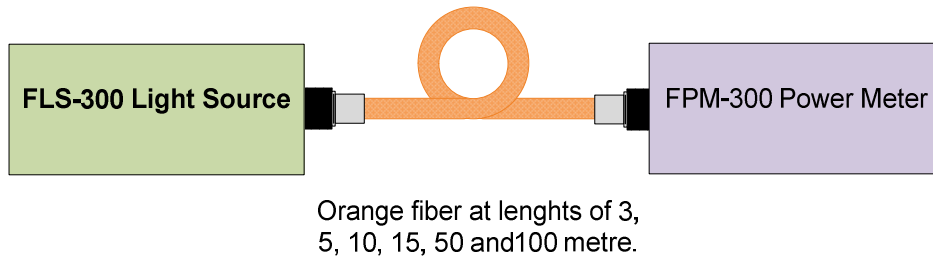

Fig 2.4 Set-up for testing the influence of the fiber length

Table 2.3 Testing result of the fiber length

Lp.	Lenght	Wavelength	Power value	Power value	Loss in [dB], with reference power value from source in -30 [dBm]
	[m]	$\lambda$ [nm]	$P_{dBm}$ [dBm]	$P_{nW}$ [nW]	$\alpha$ [dB]
1	3	850			
		1300			
2	5	850			
		1300			
3	10	850			
		1300			
4	15	850			
		1300			
5	50	850			
		1300			
6	100	850			
		1300			



**THE DEVELOPMENT OF THE POTENTIAL AND ACADEMIC PROGRAMMES OF WROCLAW UNIVERSITY OF TECHNOLOGY**

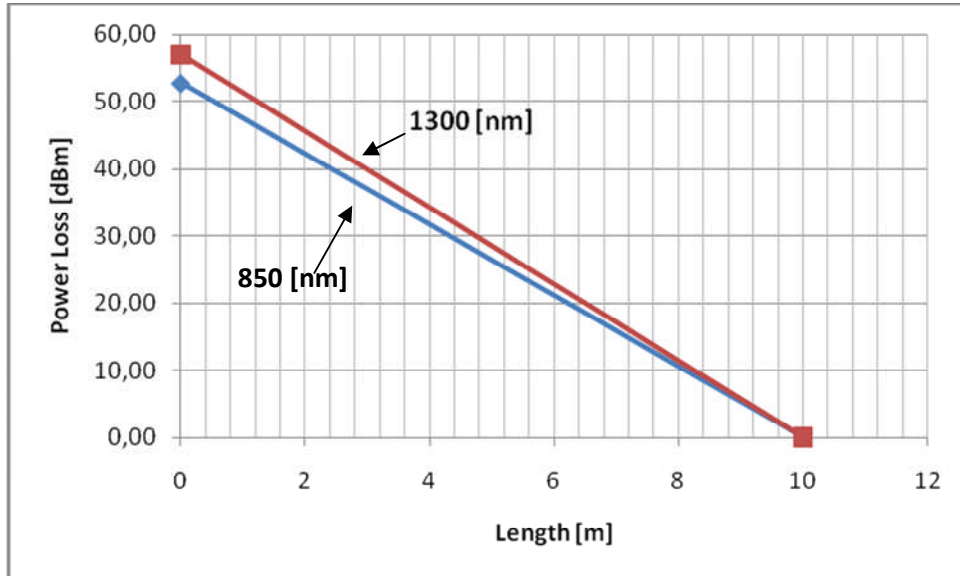

Fig. 2.5 Reference data for the blue fiber guide

**2.4. Investigation of attenuation for the fixed multisegment system**

Perform investigations in the circuit as shown in Fig 2.6 starting from 3m length and increasing gradually by 5m, 10m, 15m, 50m and terminating at the maximum total length equal to 183m. The results list in Table 2.4 and plot relationship  $P_{dBm}=f(d)$  and  $P_{nW}=f(d)$  and  $\alpha=f(d)$ . Specify conclusions. Next continue testing for the multicomponent system length equal to 100m and increase it by following (decreased in length) parts equal to 50m, 15m, 10m, 5m and terminating to 3m respectively. Follow specifying the calculations and conclusions in the way as before.

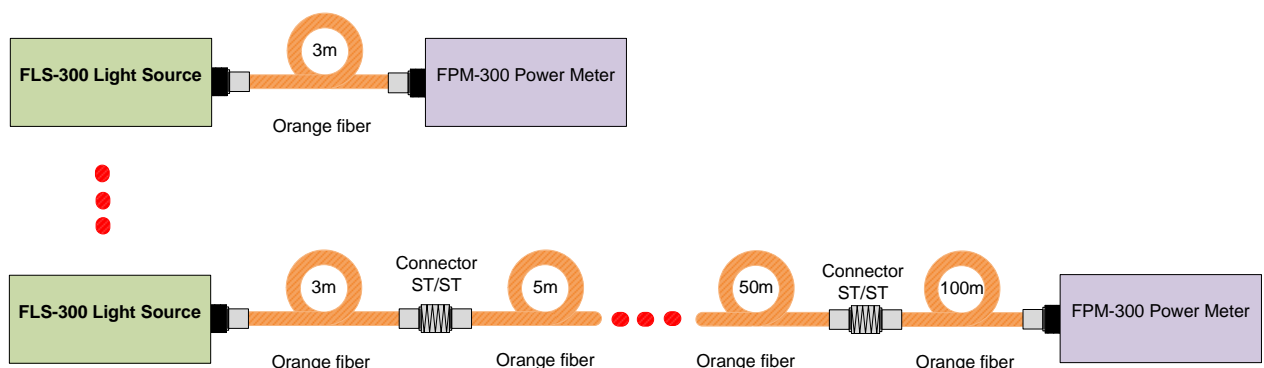

Fig 2.6 Set-up for testing the multisegment fiber system

**THE DEVELOPMENT OF THE POTENTIAL AND ACADEMIC PROGRAMMES OF WROCLAW UNIVERSITY OF TECHNOLOGY**

Table 2.4 Testing Results of multisegment transmission system

Lp.	Length of multisegment fiber path	d [m]	Wavelength	Power value	Power value	Loss in [dB], with reference power value from source in -30 [dBm]
			$\lambda$ [nm]	$P_{dBm}[dBm]$	$P_{nW}[nW]$	$\alpha[dB]$
1	3m =	3	850			
			1300			
2	3m + 5m =	8	850			
			1300			
3	3m + 5m +10m =	18	850			
			1300			
4	3m + 5m + 10m +15m =	33	850			
			1300			
5	3m + 5m +10m + 15m + 50m =	83	850			
			1300			
6	3m + 5m +10m + 15m + 50m +100m =	183	850			
			1300			

Lp.	Length of multisegment fiber path	d [m]	Wavelengths	Power value	Power value	Loss in [dB], with reference power value from source in -30 [dBm]
			$\lambda$ [nm]	$P_{dBm}[dBm]$	$\alpha[dB]$	$\alpha[dB]$
1	100m =	3	850			
			1300			
2	100m + 50m =	150	850			
			1300			
3	100m + 50m +15m =	165	850			
			1300			
4	100m + 50m +15m +10m =	175	850			
			1300			
5	100m + 50m +15m +10m +5m =	180	850			
			1300			
6	100m + 50m +15m +10m +5m +3m =	183	850			
			1300			

**THE DEVELOPMENT OF THE POTENTIAL AND ACADEMIC PROGRAMMES OF WROCLAW UNIVERSITY OF TECHNOLOGY**

**2.5. Testing of variation of the fiber attenuation for simple and multisegment transmission path**

Perform the test for fixed total length equal to 150m however, for simple as well as multisegment system as in Fig. 2.7. Follow it for two wavelength equal to 1300nm and 850nm respectively while, setting-up the results in Table 2.5. Plot the power loss – length dependence and compare it with the reference data presented in Fig 2.8 and Fig 2.9. Formulate conclusions.

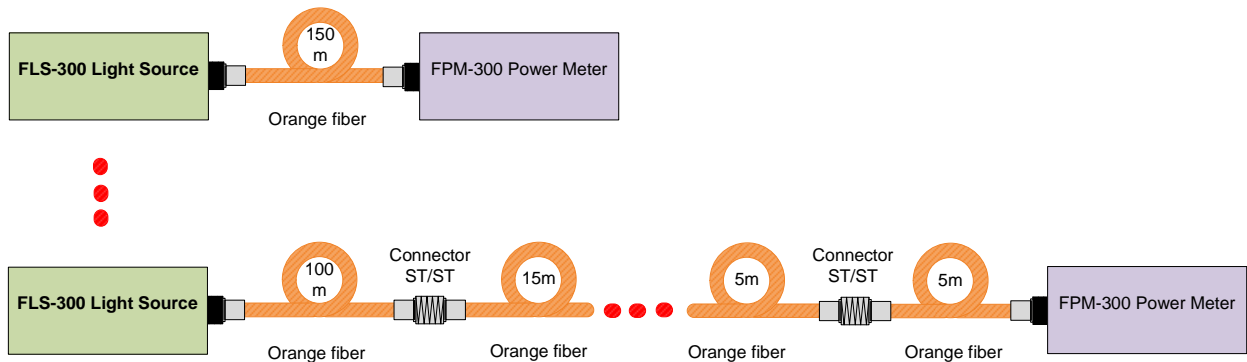

Fig. 2.7 Arrangements for testing attenuation versus on system complexity

Table 2.5 Result of comparison of the influence of system complexity

Lp.	Length of fiber	Wavelength		Power value		Loss in [dB], with reference power value from source in -30 [dBm]
		d [m]	$\lambda$ [nm]	$P_{dBm}$ [dBm]	$P_{nW}$ [nW]	$\alpha$ [dB]
1	150m =	150	850			
			1300			
6	100m+15m+15m+10m+5m+5m=	150	850			
			1300			

**THE DEVELOPMENT OF THE POTENTIAL AND ACADEMIC PROGRAMMES OF WROCLAW UNIVERSITY OF TECHNOLOGY**

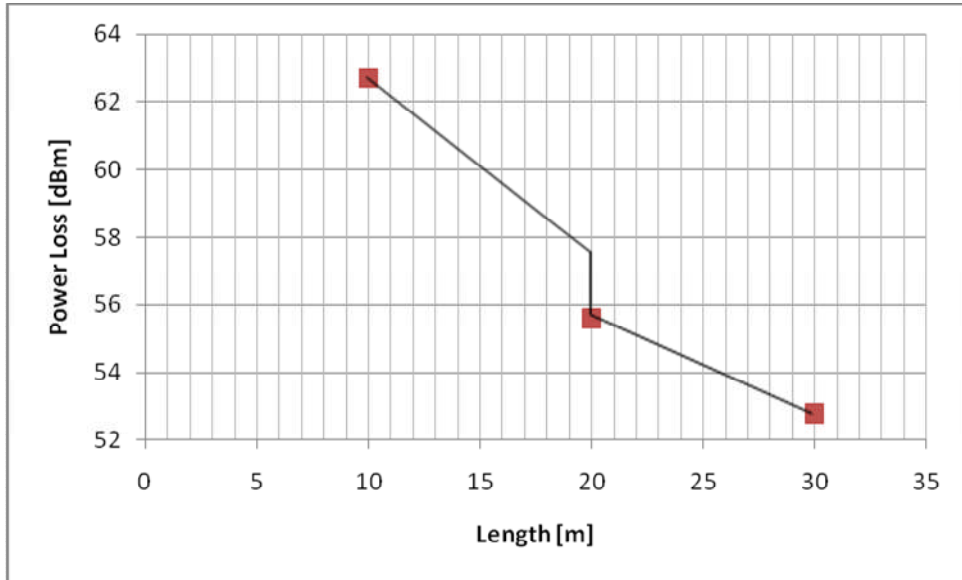

Fig. 2.8. Reference data for the blue fiber at 1300nm

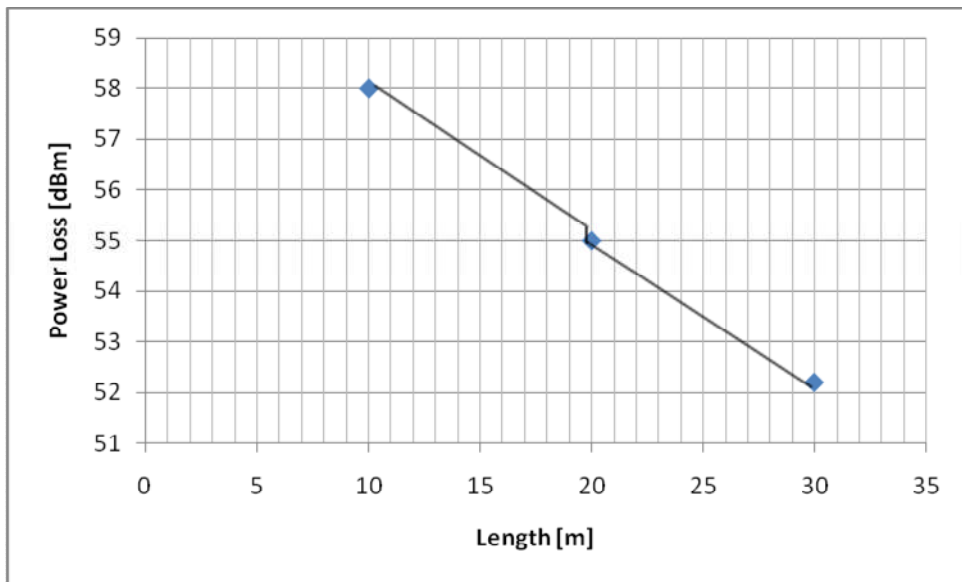

Fig. 2.9. Reference data for the blue fiber at 850nm

# TASK No 2

## ATTENUATION MEASUREMENT OF OPTICAL FIBER GUIDES

Concise specification (manual)

### 1. Introduction

Attenuation in fiber optics, also known as transmission loss, is the reduction in intensity of the light beam (or signal) with respect to distance traveled through a transmission medium. Attenuation coefficients in fiber optics usually use units of dB/km through the medium due to the relatively high quality of transparency of modern optical transmission media. The medium is typically usually a fiber of silica glass that confines the incident light beam to the inside. Attenuation is an important factor limiting the transmission of a digital signal across large distances. Thus, much research has gone into both limiting the attenuation and maximizing the amplification of the optical signal. Empirical research has shown that attenuation in optical fiber is caused primarily by both scattering and absorption.

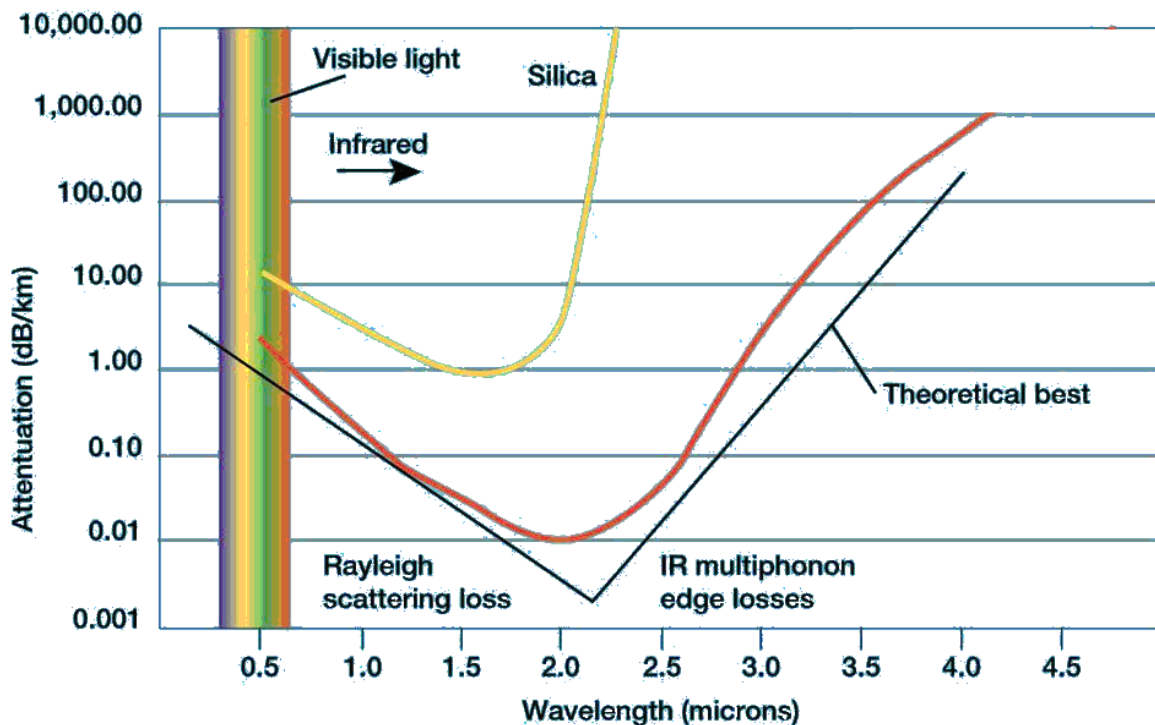

Fig. 1.1 Example of attenuation as a function of wavelength



## THE DEVELOPMENT OF THE POTENTIAL AND ACADEMIC PROGRAMMES OF WROCLAW UNIVERSITY OF TECHNOLOGY

The propagation of light through the core of an optical fiber is based on total internal reflection of the lightwave. Rough and irregular surfaces, even at the molecular level, can cause light rays to be reflected in random directions. This is called diffuse reflection or scattering, and it is typically characterized by wide variety of reflection angles.

Light scattering depends on the wavelength of the light being scattered. Thus, limits to spatial scales of visibility arise, depending on the frequency of the incident light-wave and the physical dimension (or spatial scale) of the scattering center, which is typically in the form of some specific micro-structural feature. Since visible light has a wavelength of the order of one micron (one millionth of a meter) scattering centers will have dimensions on a similar spatial scale.

Thus, attenuation results from the incoherent scattering of light at internal surfaces and interfaces. In (poly) crystalline materials such as metals and ceramics, in addition to pores, most of the internal surfaces or interfaces are in the form of grain boundaries that separate tiny regions of crystalline order. It has recently been shown that when the size of the scattering center (or grain boundary) is reduced below the size of the wavelength of the light being scattered, the scattering no longer occurs to any significant extent. This phenomenon has given rise to the production of transparent ceramic materials.

Similarly, the scattering of light in optical quality glass fiber is caused by molecular level irregularities (compositional fluctuations) in the glass structure. Indeed, one emerging school of thought is that a glass is simply the limiting case of a polycrystalline solid. Within this framework, "domains" exhibiting various degrees of short-range order become the building blocks of both metals and alloys, as well as glasses and ceramics. Distributed both between and within these domains are micro-structural defects which will provide the most ideal locations for the occurrence of light scattering. This same phenomenon is seen as one of the limiting factors in the transparency of IR missile domes.

At high optical powers, scattering can also be caused by nonlinear optical processes in the fiber.

## **2. Investigation of attenuation of the fiber guide**

The aim of investigations is to acquaint student with selected in practice measurement methods for attenuation of a simple transmission optical system.

## THE DEVELOPMENT OF THE POTENTIAL AND ACADEMIC PROGRAMMES OF WROCLAW UNIVERSITY OF TECHNOLOGY

### 2.1. Measuring arrangement and procedure

Measuring arrangement for attenuation survey of fiber optics consist of following components (see Fig 2.1 and Fig 2.2):

- Lamp
- Lamp power supply adapter ZHA -250
- Optical Chopper CH – 40
- Monochromator M250 300nm – 1200nm
- Light detector
- Oscilloscope

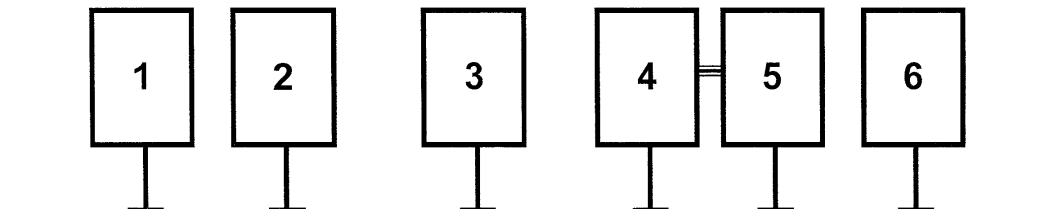

Fig 2.1 Schematic diagram for measurement of characteristics of light source and photodetector

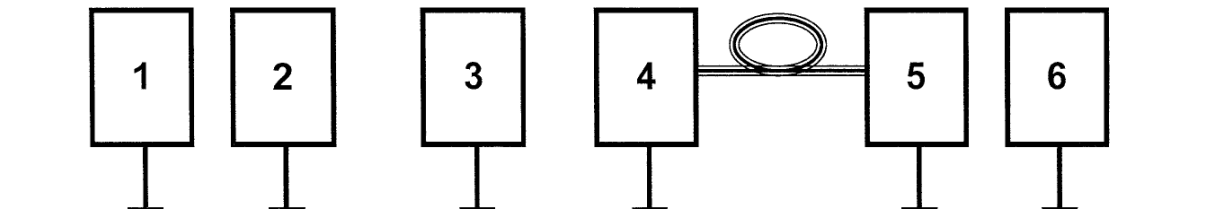

Fig 2.2 System diagram for attenuation survey of fiber optics

where:

- 1) White light source (lamp) with power supply adapter ZHA-250
- 2) Optical chopper CH-40 with frequency control
- 3) Monochromator M250
- 4) Monochromator's output ended with ST type joint
- 5) Light detector
- 6) Oscilloscope

**THE DEVELOPMENT OF THE POTENTIAL AND ACADEMIC PROGRAMMES OF WROCLAW UNIVERSITY OF TECHNOLOGY**

**2.1.1 Derivation of the light source characteristics**

Set-up the measuring circuit as in Fig 2.1 and put in motion (switch on power supply) equipment: white lights lamp, mechanical chopper and oscilloscope unit. Select the required frequency value at the optical chopper CH-40.

Control the output light power (voltage value at the detector) of white lamp (oscilloscope connected with voltmeter measures peak to peak value) for various lamp driving current (Fig. 2.1.). Next find the best (optimum) frequency with relation to power light value.

Table 2.1 Voltage-current characteristic of the light source

Lp.	I[A]	U[mV]
1		
2		

Table 2.2 Frequency characteristic of the light source

Lp.	f[Hz]	U[mV]
1		
2		

Check with the reference data shown in Fig 2.3.



**THE DEVELOPMENT OF THE POTENTIAL AND ACADEMIC PROGRAMMES OF WROCLAW UNIVERSITY OF TECHNOLOGY**

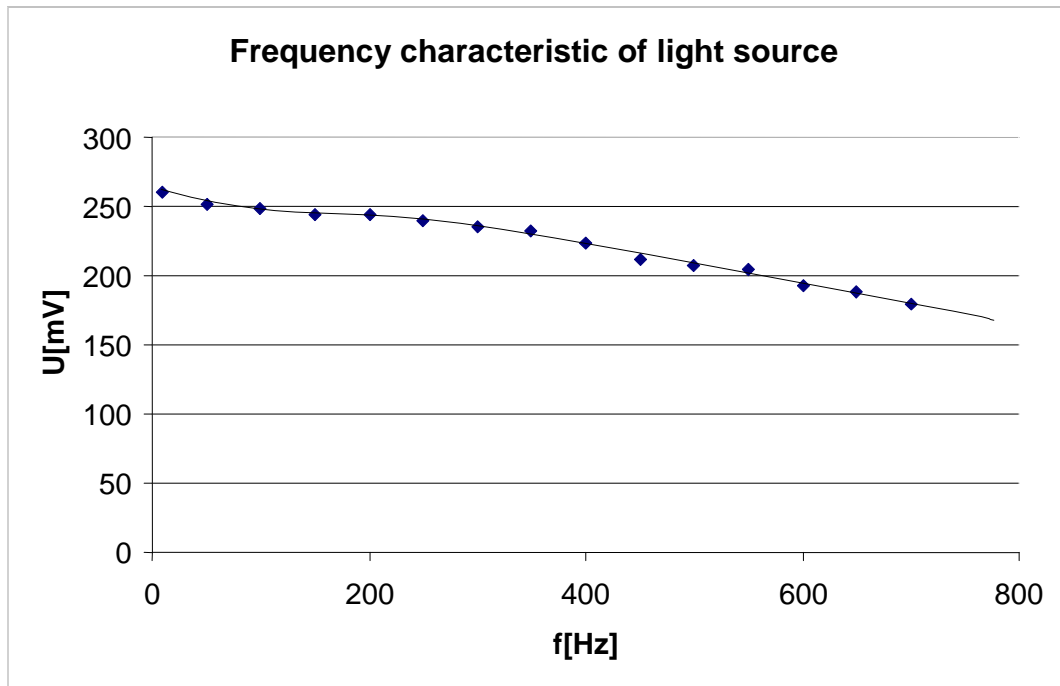

Fig. 2.3. Reference frequency characteristic of light source

**2.1.2 Frequency characteristic of the light detector**

Perform test using the same circuit as in Fig 2.1. Set – up value of the lamp current and the optical chopper frequency found at 2.1.1 point. When changing the wavelength value of the chopper derive the detector characteristic (wavelength as a function of the detector voltage). Example of measurement results are shown in Table 2.3.

Table 2.3. Fiber guide and detector characteristics

Lp.	Indication of counter	$\lambda$ [nm]	U[mV]	U[p.u.]
1	148.7	446.10	20	0.079
2	200.1	630.00	200	0.794
3	250.4	788.76	252	1
4				
5				



## THE DEVELOPMENT OF THE POTENTIAL AND ACADEMIC PROGRAMMES OF WROCLAW UNIVERSITY OF TECHNOLOGY

One should find the multiplication factor of scale of the monochromatic unit to find real value of the wave light length. Thus one has to set the monochromatic unit output so to obtain the red light and refer it to 630nm and the green light and refer it to 550nm

Example of calculation is shown below:

(1)

$\lambda$  = real value of the wave light length

$\lambda_r$  = red light

$\lambda_g$  = green light

$c$  = counter

$c_r$  = value of counter for red light

$c_g$  = value of counter for green light

$$\lambda = \lambda_r - \frac{(c_r - c) \cdot (\lambda_r - \lambda_g)}{(c_r - c_g)} = 630 - \frac{(200 - 190) \cdot (630 - 550)}{(200 - 250)} \approx 646 \quad (1)$$

$$\lambda = 646 [nm]$$

Refer the measured value of voltage to value per unit ( $U_{max}$  -max voltage value of detector)

$$U_{MAX} = 252mV$$

$$U_i = 20mV$$

$$U[p.u.] = \frac{U_i [mV]}{U_{MAX} [mV]} = \frac{20[mV]}{252[mV]} = 0,0794[p.u.] \quad (2)$$

Thus attenuation  $\alpha$  of signal is equal:

$$\alpha = U_F(\lambda) + 1 - U_D(\lambda) \quad (3)$$

where:

( $U_{D[p.u.]}$  - voltage p.u. value of detector,  $U_{F[p.u.]}$  - voltage p.u. value of fiber)

Check with the reference characteristic presented in Fig 2.4.



**THE DEVELOPMENT OF THE POTENTIAL AND ACADEMIC PROGRAMMES OF WROCLAW UNIVERSITY OF TECHNOLOGY**

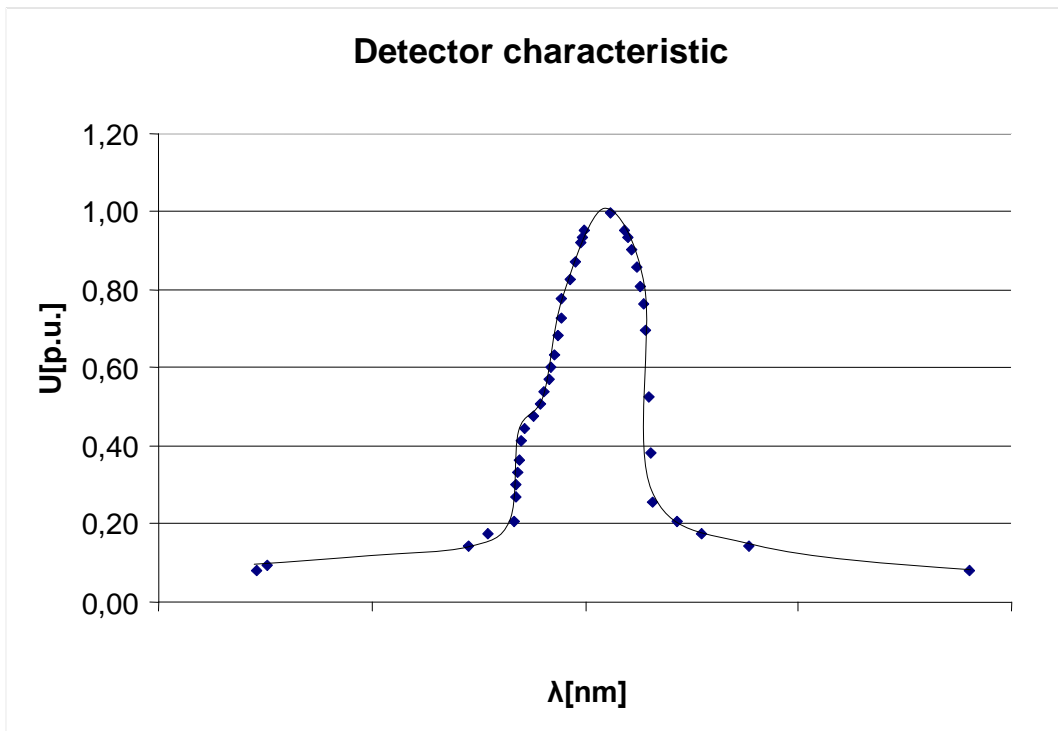

Fig. 2.4. Detector characteristic

**2.1.3 Derivation of the fiber guide characteristic**

Set-up the measuring circuit as in Fig. 2.2. Adjust values for both lamp current and the optical chopper frequency as in point 2.1.2. Derive the fiber guide characteristic (wavelength as function of voltage) when changing the monochromator wave length. Before drawing the characteristic one has to assume the detector characteristic to be linear. The measurements perform for two kinds (blue and orange) of fiber.

THE DEVELOPMENT OF THE POTENTIAL AND ACADEMIC PROGRAMMES OF WROCLAW UNIVERSITY OF TECHNOLOGY

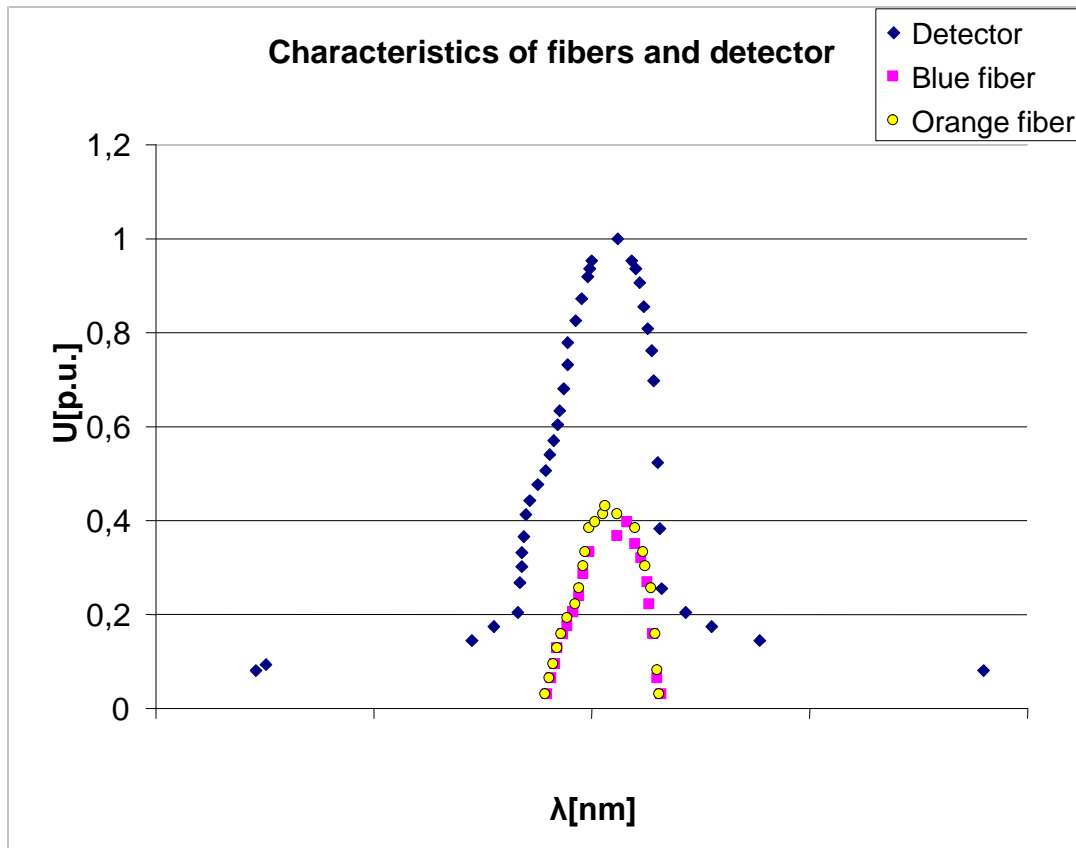
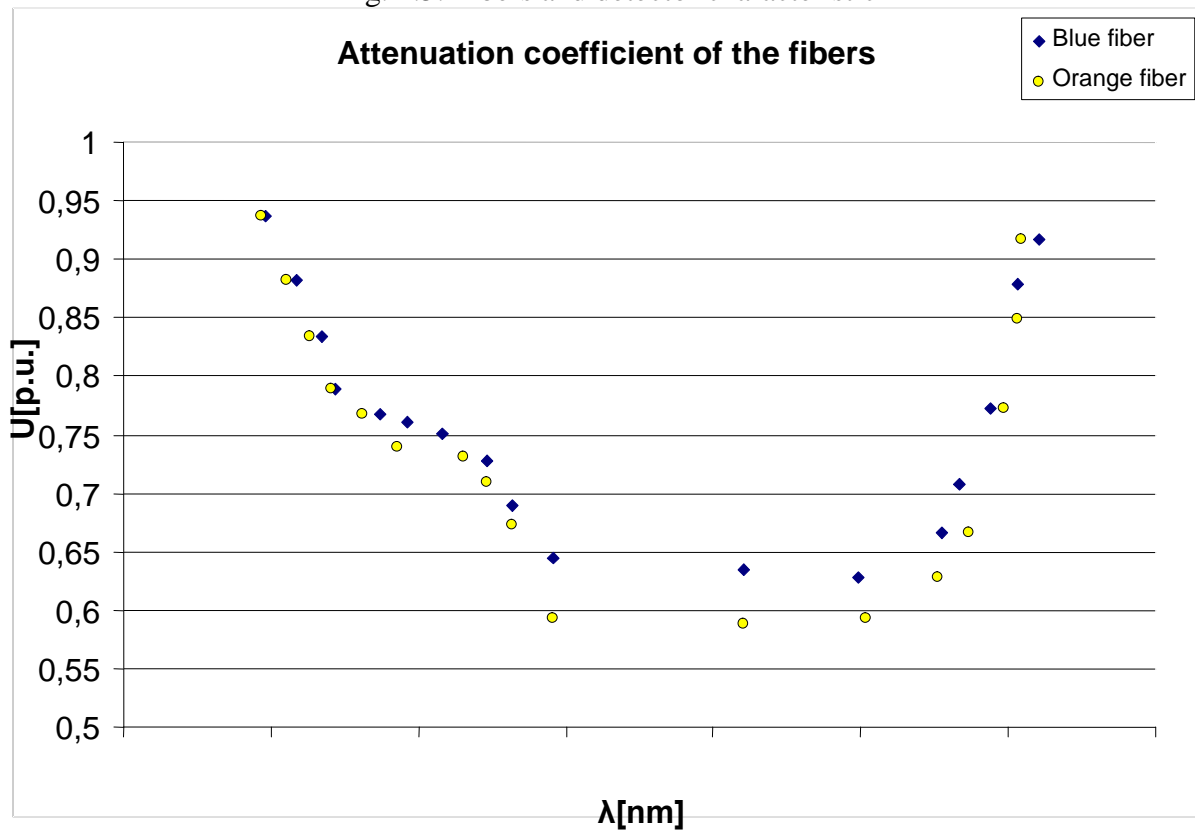

Fig. 2.5. Fibers and detector characteristic



**THE DEVELOPMENT OF THE POTENTIAL AND ACADEMIC PROGRAMMES OF WROCLAW UNIVERSITY OF TECHNOLOGY**

Fib.6. Attenuation of the signal of the fibers.

Compare the derived characteristics with the those of reference indicated in Fig 2.5 and Fig 2.6. Formulate conclusions and find out the optimum transmission window.





## TASK No 3

# TESTING OF OPTICAL POLARIZER

### Concise specification (manual)

## 1. Introduction

Light indicates properties both as a particle and as an electromagnetic wave. Its electromagnetic wave properties allow it to become polarized.

The light emanating from some sources like sun, light bulb etc. vibrates in all directions at different angles to the direction of propagation and in general is unpolarized. In many cases there is a need to produce light which vibrates in a single direction and a need to know the vibration direction of the light ray. These two requirements can be easily met when force the polarization of the light produced by the light source, by means of a polarizing filter. One has to know that the electric field intensity indicates polarization of the light ray.

Three types of polarization are possible.

- Plane Polarization
- Circular Polarization
- Elliptical Polarization

The light beam propagating in a given direction can be described as set of plane electromagnetic waves propagating along the same transmission path (Fig. 1.1).

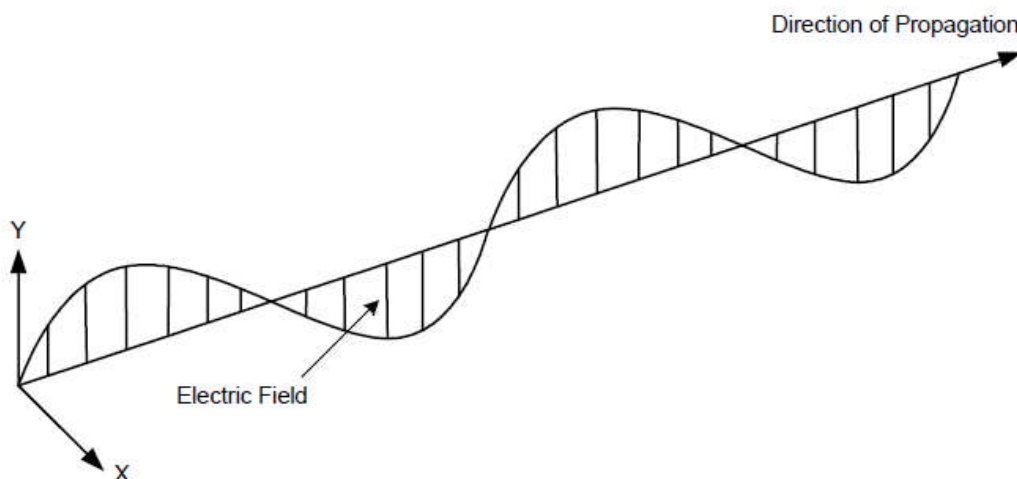

Fig. 1.1. Plane – polarized lightwave

## THE DEVELOPMENT OF THE POTENTIAL AND ACADEMIC PROGRAMMES OF WROCLAW UNIVERSITY OF TECHNOLOGY

The wave is said to be **linearly polarized** if a single electric field vector perpendicular to the direction of propagation, can represent the wave.

If light is composed of two plane waves of equal amplitude by differing in phase by  $90^\circ$ , then the light is said to be **circularly polarized**. If two plane waves of differing amplitude are related in phase by  $90^\circ$ , or if the relative phase is other than  $90^\circ$  then the light is said to be **elliptically polarized**.

Polarizer can be describe by two parameters. First one  $k_1$  sets transmission of the plate polarizator, which was lit by linear polarized beam oriented so as to obtain maximum power output. Parameter  $k_2$  sets transmission in this configuration of polarizator plate and the incident beam, to obtain a minimal power output. In the ideal situation these values are equal  $k_1=1$ ,  $k_2=0$ . In the case of real objects these parameters are equal to ratio of intensity of the outgoing beam ( $I_{out}$ ) to intensity of the beam incident ( $I_{in}$ ) respectively:

$$k_i = \frac{I_{out}}{I_{in}} \quad (1)$$

The value of the intensity of the outgoing beam for real polarizers can take its from the interval  $\langle k_1, k_2 \rangle$  and is dependent on the angle between the plane of the polarizer, and the plane of polarized beam.

Polarizers can be divided into two general categories: **absorptive polarizers**, where the unwanted polarization states are absorbed by the device, and **beam-splitting polarizers**, where the unpolarized beam is split into two beams with opposite polarization states.

The simplest polarizer in concept is the wire-grid one, which consists of a regular array of fine parallel metallic wires, placed in a plane perpendicular to the incident beam. Electromagnetic waves which have a component of their electric fields aligned parallel to the wires induces the movement of electrons along the length of the wires. Since the electrons are free to move, the polarizer behaves in a similar manner as the surface of a metal when reflecting light; some energy is lost due to Joule heating in the wires, and the rest of the wave is reflected backwards along the incident beam.

For waves with electric fields perpendicular to the wires, the electrons cannot move very far across the width of each wire; therefore, little energy is lost or reflected, and the incident wave is able to travel through the grid. Since electric field components parallel to the wires are absorbed or reflected, the transmitted wave has an electric field purely in the direction perpendicular to the wires, and is thus linearly polarized.

## THE DEVELOPMENT OF THE POTENTIAL AND ACADEMIC PROGRAMMES OF WROCLAW UNIVERSITY OF TECHNOLOGY

Another way is the polarization by use of a polaroid filter. In its original form it was an arrangement of many microscopic herapathite crystals. Its later H-sheet form is rather similar to the wire-grid polarizer. It is made of from polyvinyl alcohol (PVA) plastic with an iodine doping. Stretching of the sheet during manufacture ensures that the PVA chains are aligned in one particular direction. Electrons from the iodine dopant are able to travel along the chains, ensuring that light polarized parallel to the chains is absorbed by the sheet; light polarized perpendicularly to the chains is transmitted. The durability and applicability of polaroid make it the most common type of polarizer in use, for example for sunglasses, photographic filters, and liquid crystal displays. It is also much cheaper than other types of polarizers.

## 2. Testing stand and measuring procedure

The optical polarizer under test is controlled by an especially designed microcontroller. The laboratory stand consists of a positioning handle of the polarizer, a handle to fix the polarizer together with driving system, a light source (laser), detectors and the microcontroller (programmer) as well. (see Fig. 2.1)

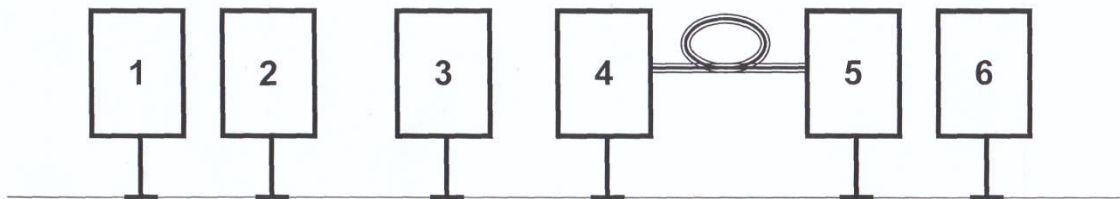

Fig. 2.1. Simplified diagram of the measuring system.

where:

1. Source of the monochromatic light – (LASER).
2. Polarization lens.
3. Polarization lens.
4. Detector.
5. Detector with fiber (optional).
6. Voltmeter.

**THE DEVELOPMENT OF THE POTENTIAL AND ACADEMIC PROGRAMMES OF WROCLAW UNIVERSITY OF TECHNOLOGY**

There are displayed their kinds of information during operation. The first parameter to be displayed is “Stopnie” (degrees). The others are “Kat” (angle) and “Nap” (voltage) respectively. The change of value of “Stopnie” (degrees) is performed by use of the press-buttons (keys) (2↓) and (8↑).

„Stopnie” (degrees)	–	displays the angle value by which the polarizer was turned
„Kat” (angle)	–	indicates the angle difference between current position of the polarizator and this at the beginning of measurements
„Nap” (voltage)	–	displays current voltage value begin set-up at the detector (in mV)

After required setting is completed one has to press the key (CLEAR↵) to turn over the polarizer. The microcontroller, according to setting-up will update both values of “Kat” (angle) and “Nap” (voltage) respectively. Depending on requirements if about sign (positive or negative) of the angle the polarizer will turn to the right or to the left. The press-button “Shift” accomplishes reset – function of the microcontroller. As a result values of both “Stopnie” (degrees) and “Kat” (angle) will be cleared.

Example of testing procedure:

- 1) After switching on the controller-press the key (4←)
- 2) Set-up required step value of the measurements – key (2↓) or (8↑)
- 3) Read off the voltage value displayed by the detector
- 4) Pass to the next measuring point – key (CLEAR↵)
- 5) Read off the voltage value of the new measuring step.
- 6) The following measures are exactly the same as on points 4 and 5 until full turn of the polarizer is made.

If any measuring point will be passed over it is possible to go back by respective value adjustment of “Stopnie” (degrees) however, at negative sign-minus – the press button (2↓) or (8↑). After having recorded the omitted measuring point, reset the measuring step by means of the press-buttons (2↓) or (8↑)

**THE DEVELOPMENT OF THE POTENTIAL AND ACADEMIC PROGRAMMES OF WROCLAW UNIVERSITY OF TECHNOLOGY**

**2.1. Procedure of testing**

- Supply equipment: red light laser and optical detector without polarizations.
- Adjust equipment to get maximum and minimum output signal of the optical detector.
- Fix one of two polarizer lens onto the base and measure the angle characteristic using voltmeter (min. resolution 2 degrees).
- Replace polarization lens with the other and repeat measurement (min. resolution 2 degrees).
- Choose one from two polarization lens to set optional angle value and repeat measurement of angle characteristic for the second lens (min. resolution 2 degrees).
- Consider the obtained measured results and formulate conclusions.

**3. Results of investigations- tables:**

Table 3.1. Reference values.

No.	Parameter	measured value
		[mV]
1	Lower reference value	
2	Upper reference value	

Table 3.2. Light intensity after passing through the first, second, and both polarizers respectively as a function of angle  $\vartheta$

No.	Angle $\vartheta$	1st Polarizer		2nd Polarizer		Both Polarizers	
	[°]	Measured value [mV]	Per unit	Measured value [mV]	Per unit	Measured value [mV]	Per unit
1	0						
2	2						
3	4						
4	6						
5	8						
6	10						
7	12						

**THE DEVELOPMENT OF THE POTENTIAL AND ACADEMIC PROGRAMMES OF WROCLAW UNIVERSITY OF TECHNOLOGY**

**Example of calculation:**

$$X_i = \frac{X_p - W_D}{W_G - W_D} \tag{1}$$

$X_i$  - Value of standardized measurement [p.u.].

$X_p$  - Measured value [mV];

$W_D$  - Lower reference value [mV];

$W_G$  - Upper reference value [mV];

**Example of chart:**

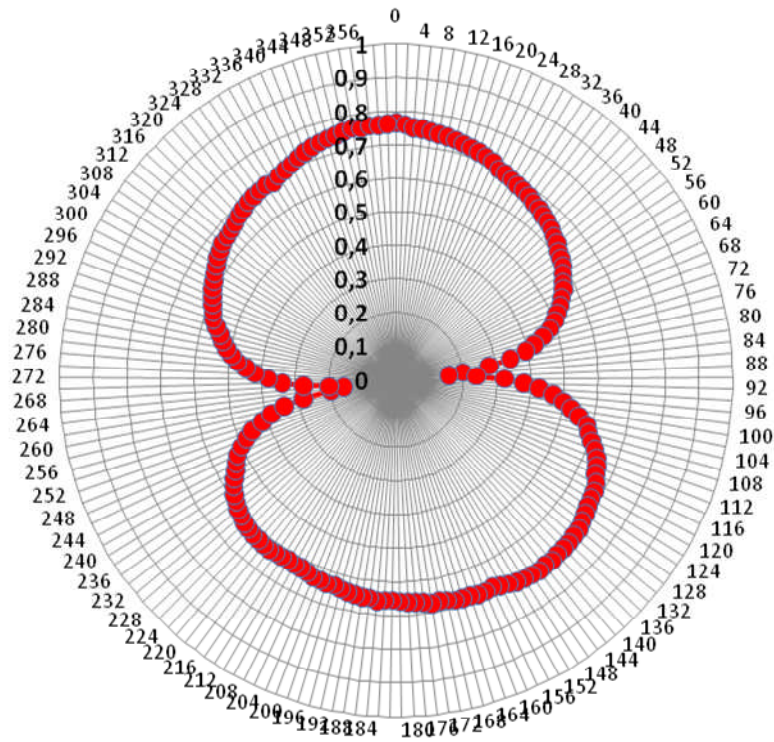

Fig. 3.1. Chart of the light intensity after passing through both polarizes

## **TASK No 4**

# **INVESTIGATION OF RADIATION ANGULAR CHARADCTERISTICS OF SEMICONDUCTOR LASERS**

**Concise specification (manual)**

## **1. Introduction**

Laser (Light Amplification by Stimulated Emission of Radiation) is a device which produces electromagnetic radiation, often visible light, using the process of optical amplification based on the stimulated emission of photons within a so-called gain medium. The emitted laser light is notable for its high degree of spatial and temporal coherence, unattainable using other technologies. Temporal (or longitudinal) coherence implies a polarized wave at a single frequency whose phase is correlated over a relatively large distance (the coherence length) along the beam. This is in contrast to thermal or incoherent light emitted by ordinary sources of light whose instantaneous amplitude and phase varies randomly with respect to time and position. Although temporal coherence implies monochromatic emission, there are lasers that emit a broad spectrum of light, or emit different wavelengths of light simultaneously.

Most so-called "single wavelength" lasers actually produce radiation in several modes having slightly different frequencies (wavelengths), often not in a single polarization. There are some lasers which are not single spatial mode and consequently their light beams diverge more than required by the diffraction limit. However all such devices are classified as "lasers" based on their method of producing that light and are generally employed in applications where light of similar characteristics could not be produced using simpler technologies.

Solid-state laser materials are commonly made by "doping" a crystalline solid host with ions that provide the required energy states. For example, the first working laser was a ruby laser, made from ruby (chromium-doped corundum). The population inversion is actually maintained in the "dopant", such as chromium or neodymium. Formally, the class of solid-state lasers includes also fiber laser, as the active medium (fiber) is in the solid state. Practically, in the scientific literature, solid-state laser usually means a laser with bulk active medium, while wave-guide lasers are called fiber lasers.



**THE DEVELOPMENT OF THE POTENTIAL AND ACADEMIC PROGRAMMES OF WROCLAW UNIVERSITY OF TECHNOLOGY**

"Semiconductor lasers" are also solid-state lasers, but in the customary laser terminology, "solid-state laser" excludes semiconductor lasers, which have their own name. One of the typical green laser pointer is shown in Fig.1.1 as an example.

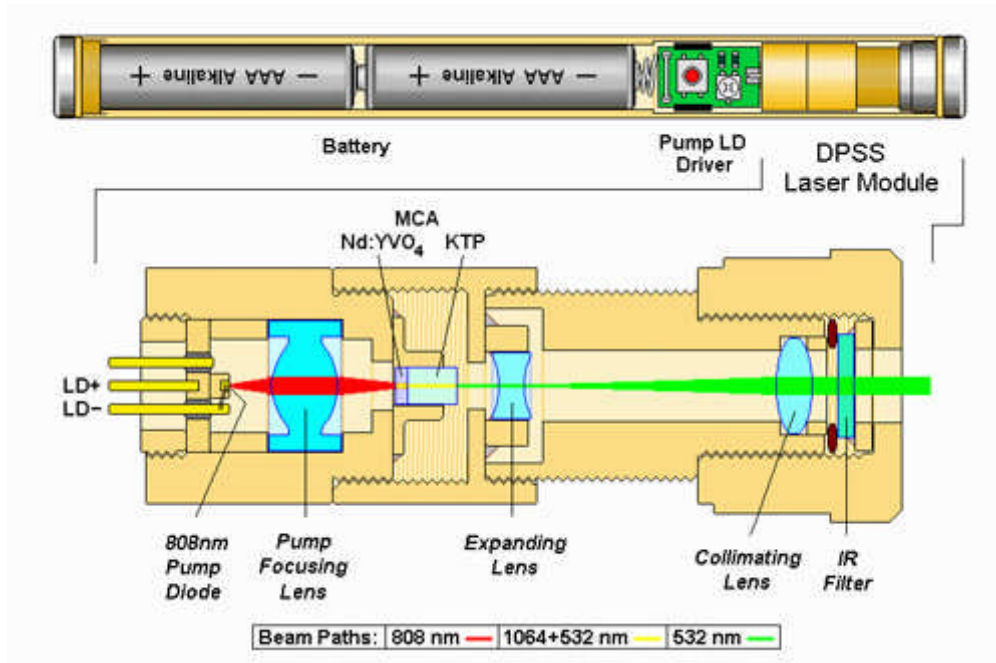

Fig. 1.1 Cross section of the typical Green Laser „pointer”

It is the frequency-doubled green light laser source. The IR diode of 808nm pumps energy to Nd:YVO4 laser crystal, that as a result produces 1064 nm output light. However this light is immediately doubled inside a non-linear KTP crystal, resulting in a green light at the half-wavelength of 532 nm. This beam length is next expanded and infrared-filtered. In cheap laser structures the IR filter is omitted.

The most of the semiconductor light sources are equipped with integrated lenses system at the output. As a result the output beam of both LEDs and LDs is respectively collimated to adjust properly both axis (optical as well as geometrical) to be parallel as in Fig.1.2 otherwise the correct operation of any semiconductors light source is would be missed.



THE DEVELOPMENT OF THE POTENTIAL AND ACADEMIC PROGRAMMES OF WROCLAW UNIVERSITY OF TECHNOLOGY

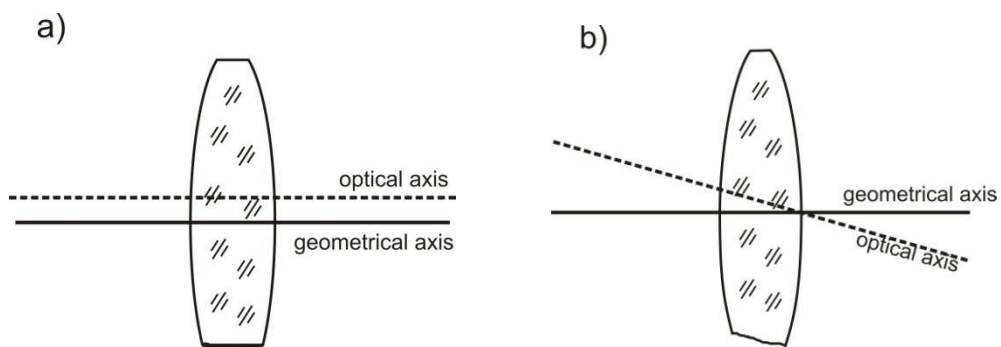
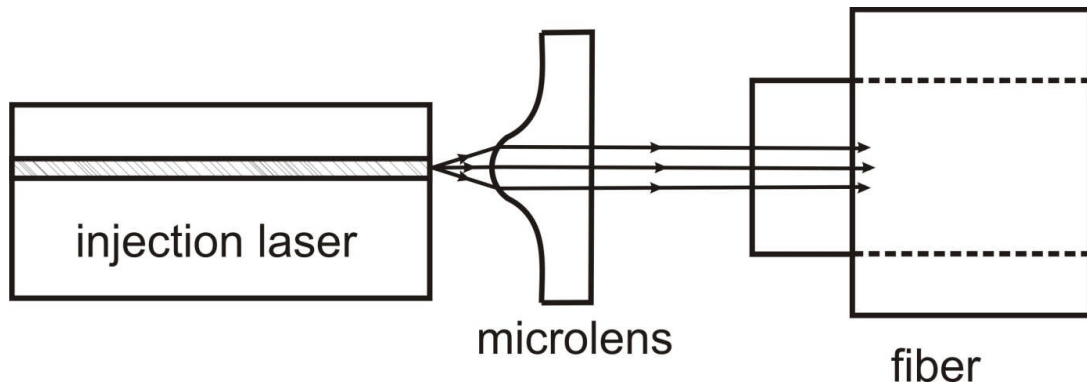

Fig. 1.2. Explanation of the collimation effect a) correct, b)incorrect

## 2. Investigation of radiation characteristics of semiconductor laser

The radiation characteristics (the far field distribution of the light) for two selected semiconductor lasers (green and red) shall be measured by means of optical arrangement being set-up as illustrated in Fig.2.1.

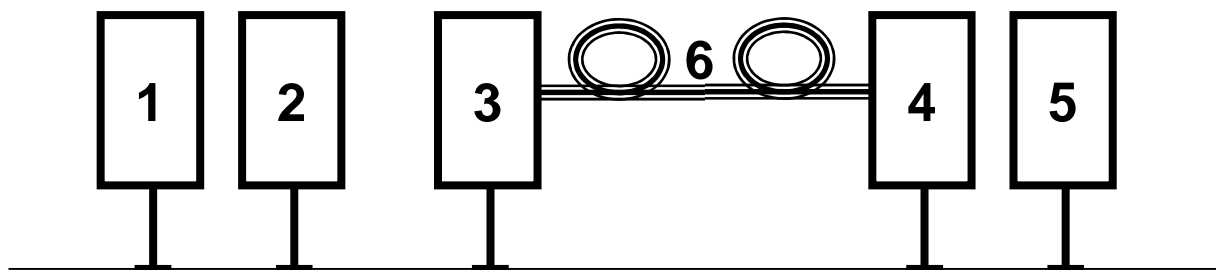

Fig.2.1. Schematic of the optical set-up for measurements

1. Source of monochromatic light – RED LASER.
2. Source of monochromatic light – GREEN LASER.
3. Rotary table.



**THE DEVELOPMENT OF THE POTENTIAL AND ACADEMIC PROGRAMMES OF WROCLAW UNIVERSITY OF TECHNOLOGY**

4. Detector.
5. Voltmeter or oscilloscope.
6. Selected and especially prepared fiber guide.

**2.1. Testing procedure**

- supply the equipment (red light laser and optical detector system) on,
- adjust the equipment operation conditions to provide both maximum and minimum value at the output of the fotodetector (it is measured by voltmeter),
- control the lateral angular characteristic of the laser and adjust the angle to be equal to 0, a half, and maximum optical power value (at the output) respectively. Repeat the testing procedure at last three time to calculate the average value.
- move next away the detector from the laser source (on the optical bench) at selected longer distance and repeat the measurements as under the step mentioned above. Perform the test for at least three different the detector-laser distances.
- Execute the measurements for both red and green light lasers to compare results.

The investigated resulted results put into respective Table 1 or 2.

Table 1. Results for the red laser

a) distance: 60cm.

U [mV]		310	450		
U [p.u]		0.68	1		
$\Theta$ [degree]	-2	-1	0	1	2

b) distance: 40cm.

U [mV]					
U [p.u]					
$\Theta$ [degree]			0		

c) distance: 20cm.

U [mV]					
U [p.u]					
$\Theta$ [degree]			0		

THE DEVELOPMENT OF THE POTENTIAL AND ACADEMIC PROGRAMMES OF WROCLAW UNIVERSITY OF TECHNOLOGY

Table 2. Results for the green laser

a) distance: 60cm.

U [mV]					
U [p.u]					
Θ [degree]			0		

b) distance: 40cm.

U [mV]					
U [p.u]					
Θ [degree]			0		

c) distance: 20cm.

U [mV]					
U [p.u]					
Θ [degree]			0		

The p.u. of voltage is referred to maximum  $U_{max}$  value of the laser output as follows:

for example for the red laser:

$$U_{MAX} = 450.0 \text{ mV}$$

therefore, for the measured value:

$$U_i = 310.0 \text{ mV}$$

the U expressed in [p.u.] is equal:

$$U[p.u.] = \frac{U_i[mV]}{U_{MAX}[mV]} = \frac{310.0[mV]}{450.0[mV]} = 0.68[p.u] \quad (1)$$

On the basis of the investigated results plot respective characteristics and compare with these presented in Fig.2.2. Specify respective conclusions.



THE DEVELOPMENT OF THE POTENTIAL AND ACADEMIC PROGRAMMES OF WROCLAW UNIVERSITY OF TECHNOLOGY

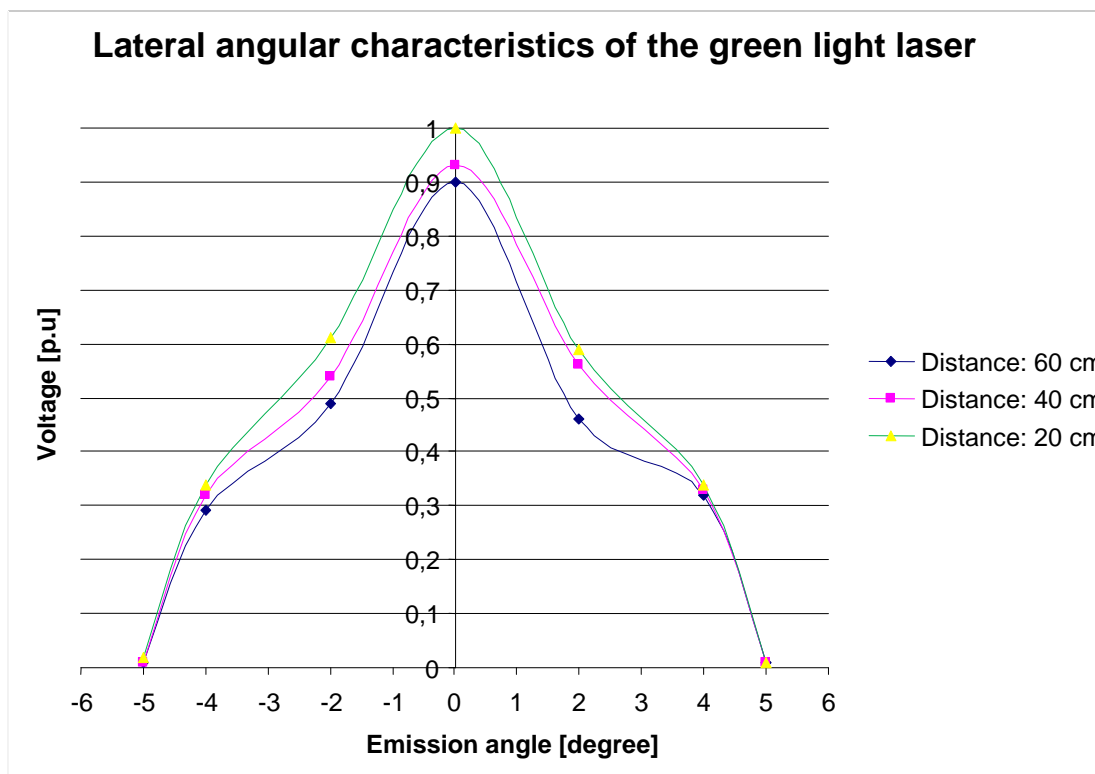
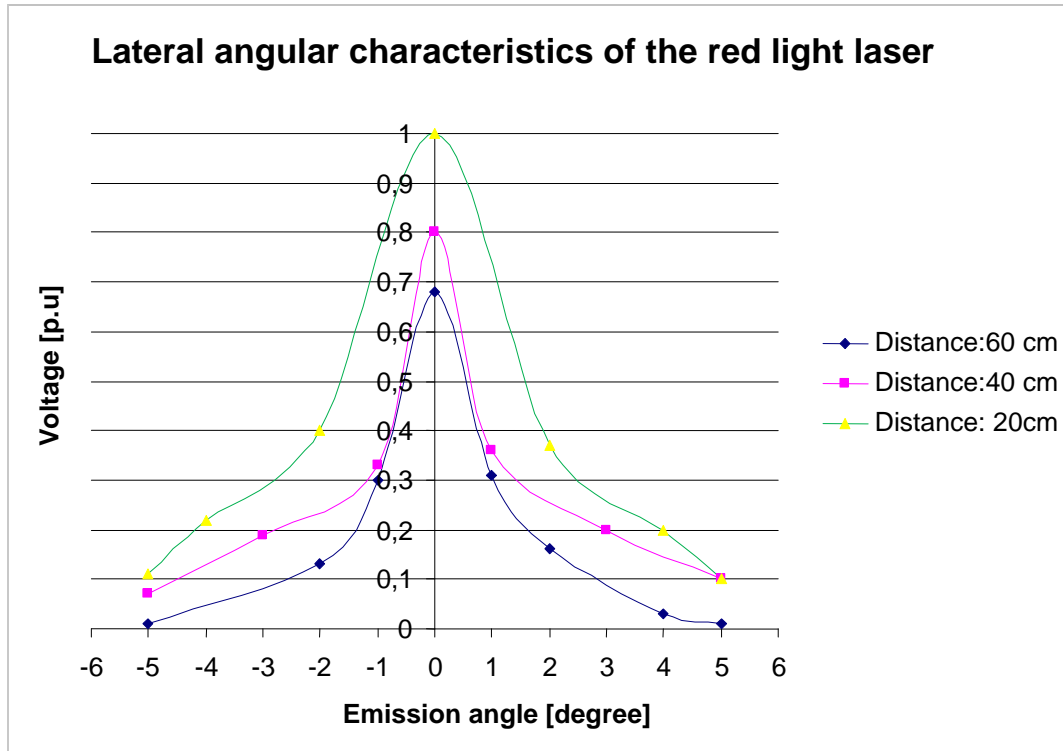

Fig.2.2. Far field distribution of the light emission for two selected semiconductor lasers (green and red)

THE DEVELOPMENT OF THE POTENTIAL AND ACADEMIC PROGRAMMES OF WROCLAW UNIVERSITY OF TECHNOLOGY

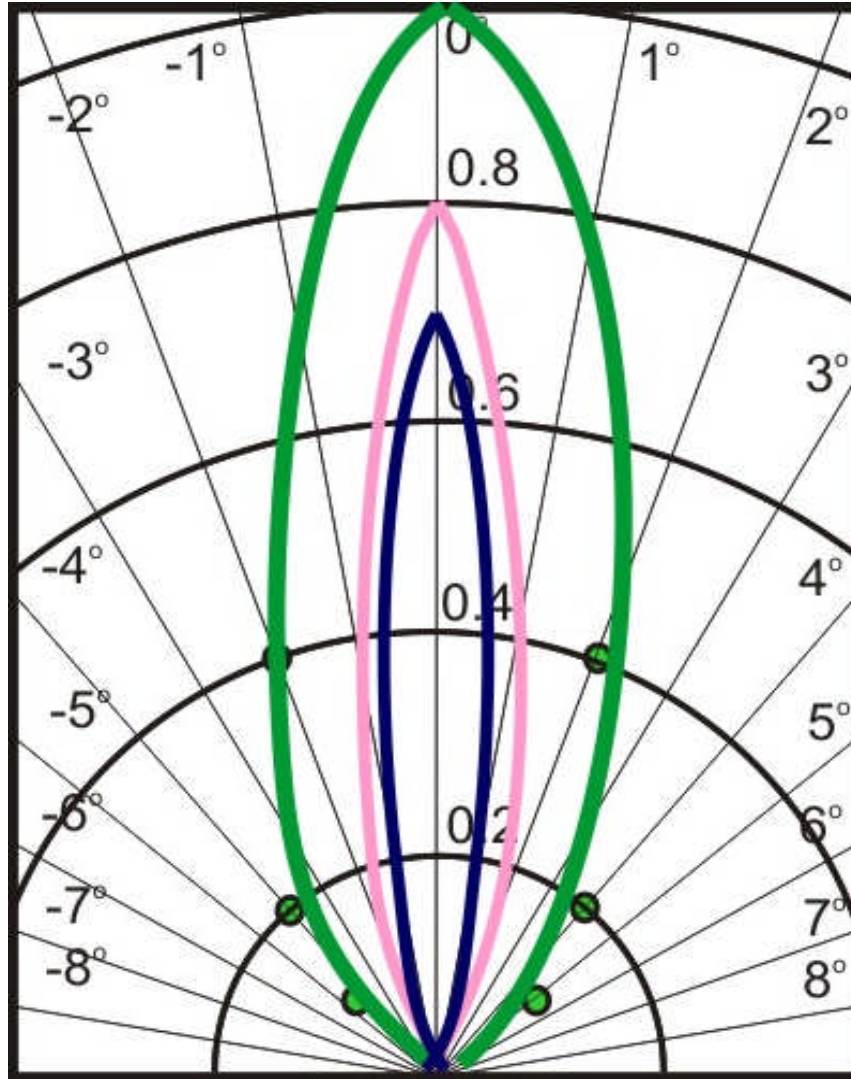

Fig.2.3. Example of far field distribution of the light emission for selected semiconductor lasers (green and red) (Emission angle x10 [degree])

# TASK No 5

## INVESTIGATION OF OUTPUT SPECTRUM AND LIGHT-CURRENT CHARACTERISTICS OF OPTICAL LIGHT SOURCE

Concise specification (manual)

### 1. Introduction

Light - emitting diode (LED) is semiconductor device composed of two types semiconductors: p-type and n-type respectively creating a semiconductor p-n junction. The semiconductor junction it is a metallurgically formed single-crystal alloy of two semiconductor materials. There are two types of the junctions:

- p-n homojunction is formed with n- and p-types of the same host material (e.g. Si),
- p-n heterojunction – of different materials respectively.

By applying external sources of energy (electrical, optical, etc) electrons and holes created in excess of the equilibrium densities. If the p-n junction is forward-biased it means that external potential is applied to reduce the barrier potential and allows easier drift of electrons and holes (see Fig.1.1).

Therefore, the recombination of carriers is performed and energy is released in term of radiation:

$$W = E_g = h \cdot f \quad (1)$$

where:  $f$  – frequency of radiation;  $h$  – Plank's constant ( $6.626 \cdot 10^{-34}$  Js)

Thus the wave – length  $\lambda$  to be emitted is:

$$\lambda = \frac{h \cdot c}{E_g} \quad (2)$$

where:  $c$  – speed of light in a free space;  $E_g$  in [eV];  $\lambda$  in [ $\mu\text{m}$ ].

Depending on the band gap energy  $E_g$  value one can produce the wave length in some (however, limited) range as it is presented in table 1.



**THE DEVELOPMENT OF THE POTENTIAL AND ACADEMIC PROGRAMMES OF WROCLAW UNIVERSITY OF TECHNOLOGY**

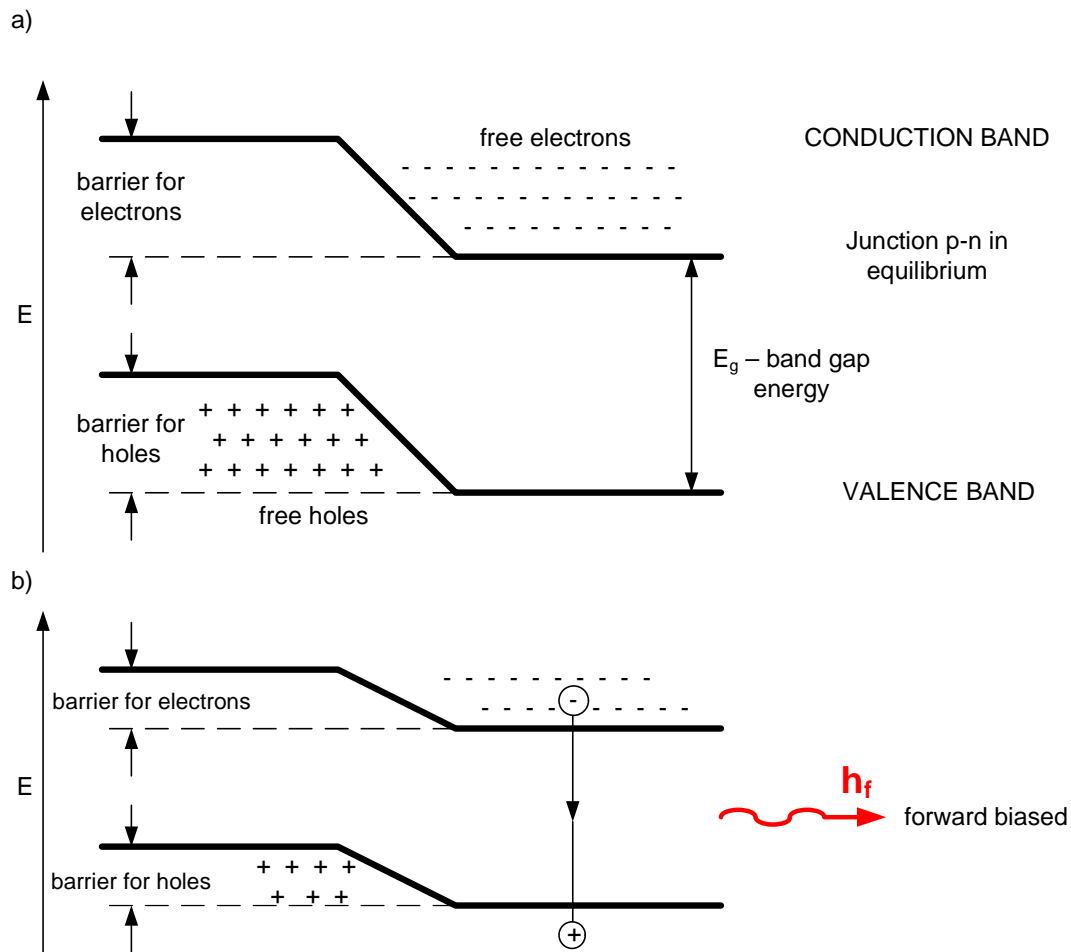

Fig.1.1. Explanation of the LED performance a) junction in equilibrium b) when forward biased

Table 1. Variation of the wave length with gap energy

Material	Band gap energy $E_g$ [eV]	Wave $\lambda$ [ $\mu\text{m}$ ]
GaAs	1.4	0.9
AlGaAs	1.4÷1.55	0.8÷0.9
InGaAs	0.95÷1.55	1.0÷1.3
InGaAsP	0.73÷1.35	0.9÷1.7

There are two basic types of the LED's: surface (planar, dome) emitting diodes and edge-emitting diodes. The p-n homojunction light emitting diodes (see Fig.1.2) produce scattered radiation (both from the surface as well as from the edge). It results in poor coupling efficiency with the fiber guide.

THE DEVELOPMENT OF THE POTENTIAL AND ACADEMIC PROGRAMMES OF WROCLAW UNIVERSITY OF TECHNOLOGY

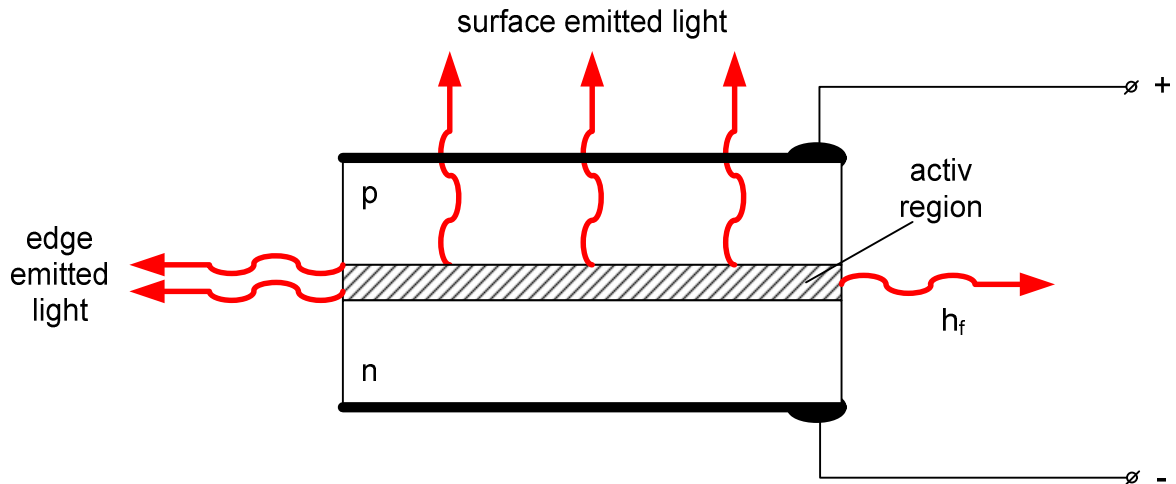

Fig.1.2. P-N homojunction LED

Therefore, much better coupling properties are found for the planer LEDs however, with p-n heterojunctions. Typical surface emitter (Burns type) is presented in Fig.1.3.

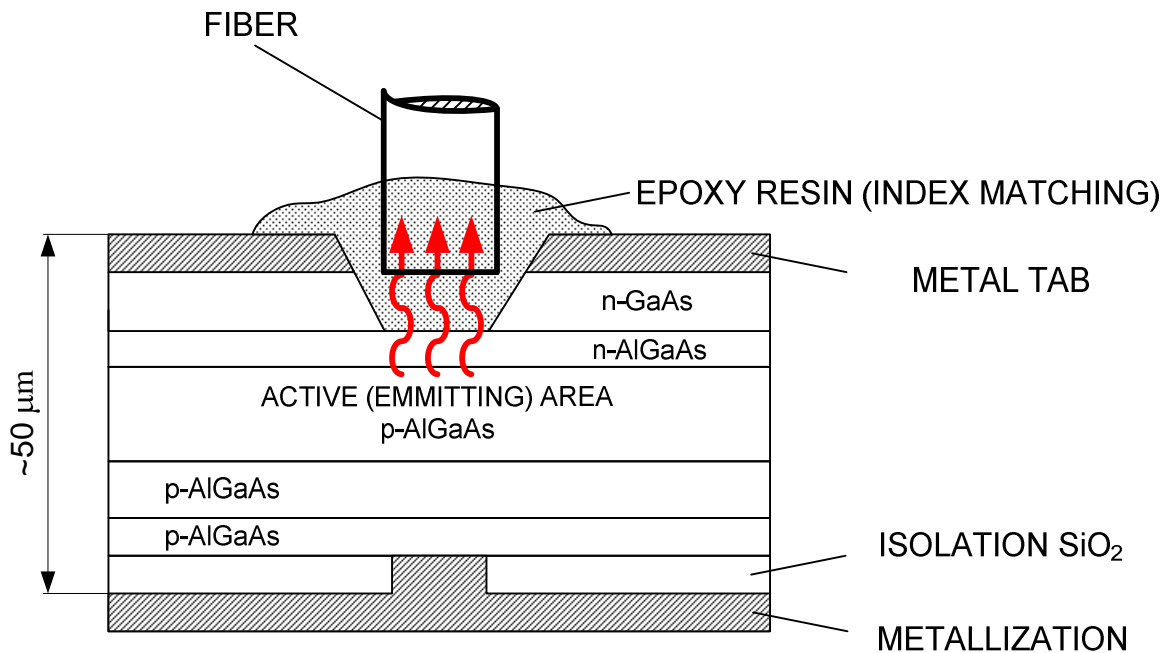

Fig.1.3. Surface emitter (Burns type) heterojunction LED

The best for coupling are the edge-photodiodes. They provide reduced beam width and although the emitting area of an edge-emitting LED is normally less than that of the surface emitter, actually more absolute power can be coupled into the fiber with numerical aperture



**THE DEVELOPMENT OF THE POTENTIAL AND ACADEMIC PROGRAMMES OF WROCLAW UNIVERSITY OF TECHNOLOGY**

$NA \leq 0.3$  (SMFs). The LEDs are linear light-current devices however, indicating the incoherent emission of a wide out-put spectrum (see Fig.1.4).

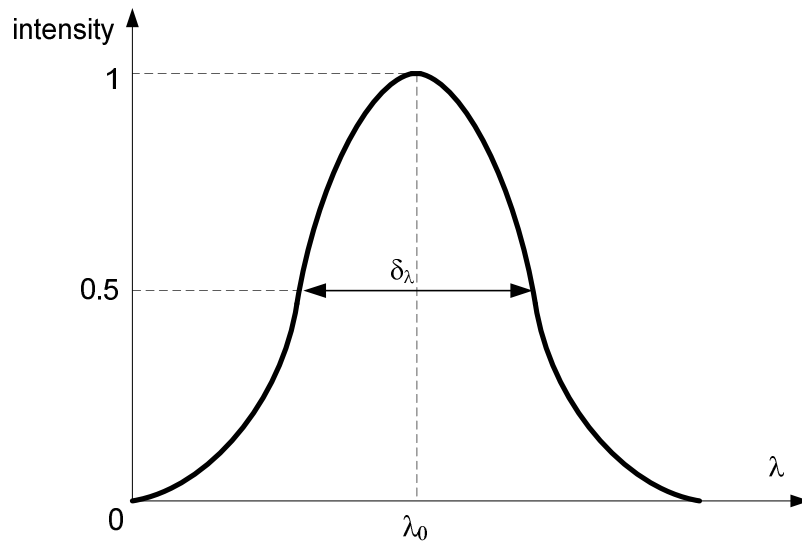

Fig.1.4. Out-put spectrum of LED

e.g.:

$\lambda_0 \sim 0.8 \div 0.9 \mu\text{m}$	$\delta_\lambda \sim 20 \div 40 \text{ nm}$
$\lambda_0 \sim 1.0 \div 1.7 \mu\text{m}$	$\delta_\lambda \sim 50 \div 100 \text{ nm}$

They also indicate variation of the  $\lambda_{\text{peak}}$  shift with temperature around  $0.3 \div 0.4 \text{ nm}/^\circ\text{C}$ .

The radiation characteristic is symmetrical for the surface emitting LED indicating nonsymmetrical radiation intensity for the edge emitting LED as illustrated for example in Fig.1.5. On the contrary lasers produce the highly coherent emission of a narrow spectral with the light amplification. However they are threshold devices (driving current has to be over current threshold value) and are sensitive to temperature. Therefore the temperature compensation is obligatory for reliable operation.

THE DEVELOPMENT OF THE POTENTIAL AND ACADEMIC PROGRAMMES OF WROCLAW UNIVERSITY OF TECHNOLOGY

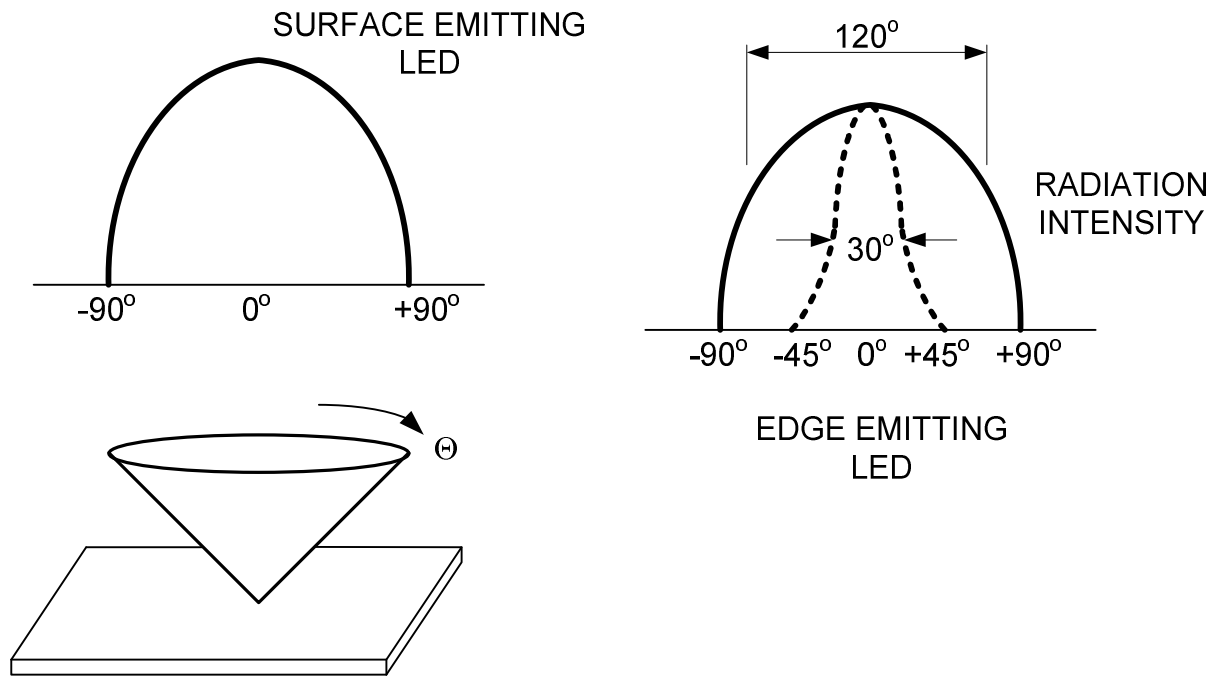

Fig.1.5. Radiation characteristics of the LEDs

## 2. Testing arrangement

To control the output spectrum and the light-current characteristics of both LED and LD diodes a spectrophotometer has to be used (Fig.2.1). Schematic of the set-up for testing is indicated in Fig.2.2.



Fig. 2.1. View of the spectrophotometer applied

**THE DEVELOPMENT OF THE POTENTIAL AND ACADEMIC PROGRAMMES OF WROCLAW UNIVERSITY OF TECHNOLOGY**

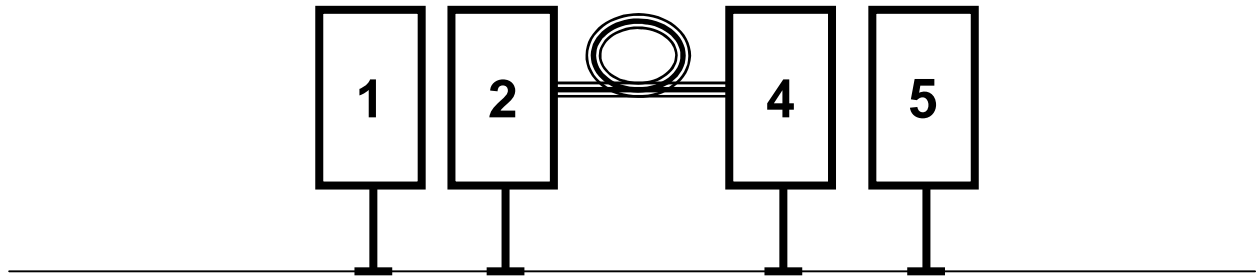

Fig.2.2. Schematic of the optical setup for measurements; 1. Light Source, 2. ST standard connectors, 3. Especially selected fiber optics, 4. Spectrophotometer, 5. Computer with software.

### 2.1. Testing procedure

Two types of the light emitting sources are selected for testing: Light emitting diodes (LEDs) and laser diodes (LDs) respectively. The measurements are carried out as follows:

- power the whole equipment (computer with software, spectrophotometer and optical source system) on,
- measure the out-put spectrum for all diodes selected at maximum driving current value. Control the wave length (beginning, maximum intensity and end of spectral width) and the radiation intensity (example of the measured spectrum for ordinary bulb is seen in Fig.8),
- measure the out-put spectrum for the sun light and for commonly used light sources (bulb, glow-discharge tube) and compare with this for the LED generating the white light (conduct the testing at similar way and range as at above mentioned point),
- repeat the measurements as above but only for selected LEDs and LDs to control the light-current characteristics. The driving current value must be changed in wide range from minimum and maximum specified control values of the particular light source,
- try to control the spectrum of the multimode – RGB LED to obtain the visible white light.

The investigated results list in respective Tables (as for example in Table 1 for the red light LD). On the basis of the investigated results plot both output spectrums and light-current characteristics for the light sources investigated (some examples for comparison are presented in Fig.2.3. ÷ Fig.2.5. Specify conclusions.



**THE DEVELOPMENT OF THE POTENTIAL AND ACADEMIC PROGRAMMES OF WROCLAW UNIVERSITY OF TECHNOLOGY**

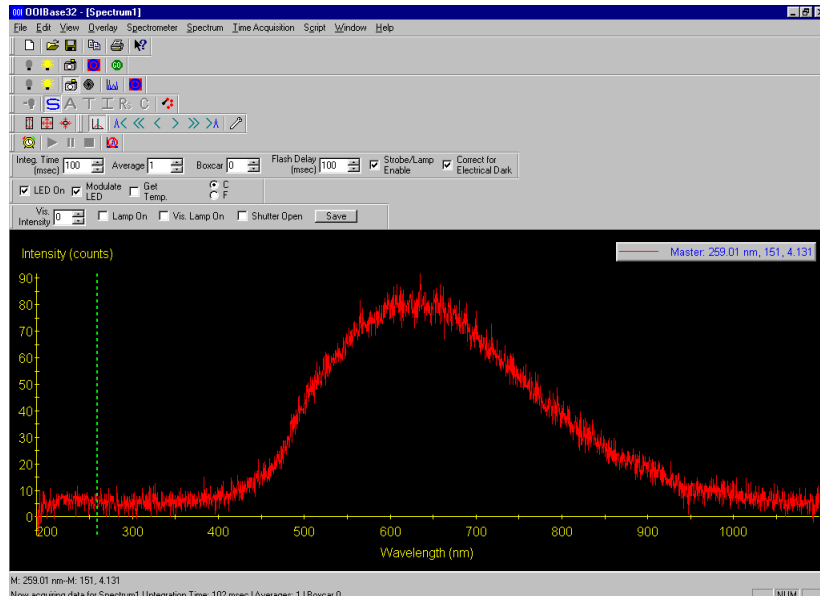

Fig. 2.3. Example of output spectrum for ordinary bulb

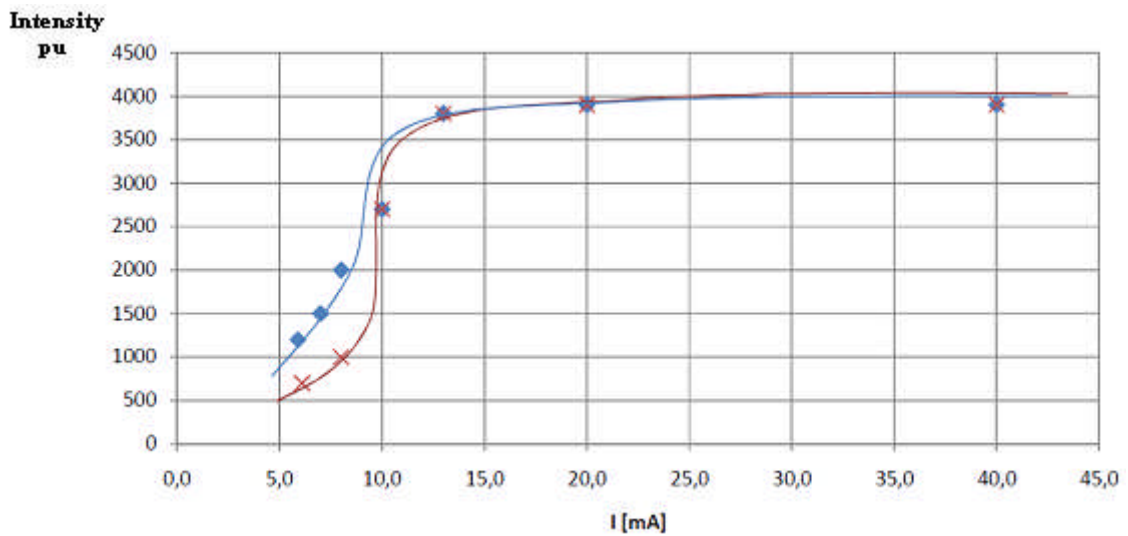

Fig.2.4. Light-current characteristic for LED and LD (◊ - intensity of laser diode LD, x - intensity of red LED)



**THE DEVELOPMENT OF THE POTENTIAL AND ACADEMIC PROGRAMMES OF WROCLAW UNIVERSITY OF TECHNOLOGY**

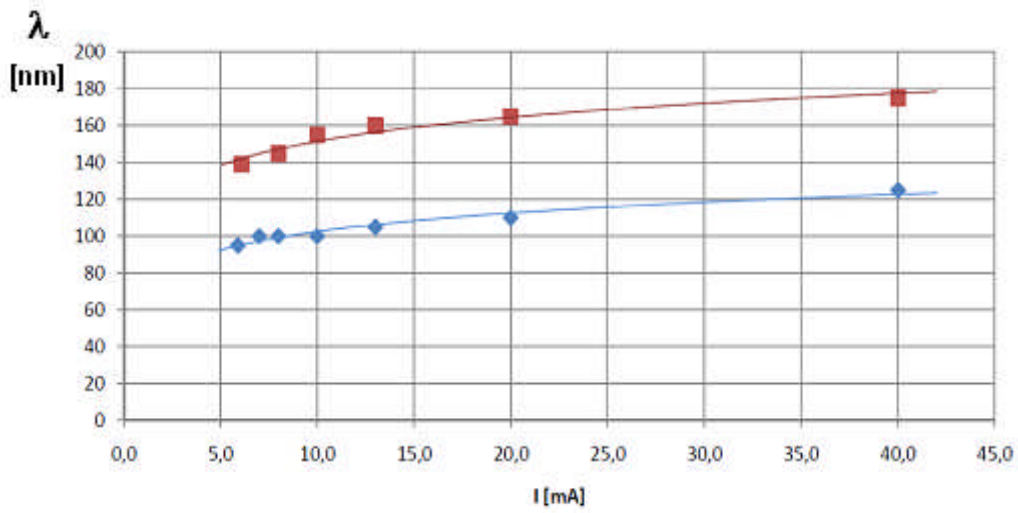

Fig.2.5. Wave-length versus driving-current (◇ - wave length of laser diode, □ – wave length of red diode)

Table 1. Results of measurements for red light LD

No	Intensity	Current	wave length			
			start	max	stop	remarkable
[-]	[-]	[mA]	[nm]			
1.						
2.						
3.						

# TASK No 6

## INVESTIGATION OF MATCHING EFFICIENCY OF OPTICAL CONNECTORS

Concise specification (manual)

### 1. Introduction

In fiber optical transmission systems the connections are among others elements very important passive components. They are needed both to extend the fiber length (single fiber length is up to about 1 km) and/or to provide communication link between the fiber guide and various measuring and controlling as well as metering equipments. In use there are two basic types of connections: fiber splices (semi-permanent and/or permanent joints) and fiber connectors (non-permanent/demountable). It is extremely difficult to make a perfect joint since, the losses at connection area are unavoidable. One distinguishes here so called intrinsic (immanent) losses related strictly to internal properties and manufacturing technology and extrinsic losses which are introduced from outside under assembling. Since, the air gap usually exists between two separated parts of the fiber guides being connected therefore, due to involve fiber – air interfaces there are losses generated due to the rays reflection from the interfaces (leaky modes). These losses are described by Fresnel formula:

$$r = \left( \frac{n_f - n_0}{n_f + n_0} \right)^2 \quad (1)$$

where:  $r$  – fraction of light reflected at the interface,

$n_f$  – core refractive index,

$n_a$  – air refractive index (equal to 1).

$$l_{\text{lossFresnel}} = 10 \log(1 - r) \quad (2)$$

The intrinsic losses are due to such parameters as:

- core diameter differences,
- numerical aperture differences,
- core-cladding eccentricity,
- index profile mismatching (for the graded-index fibers),

while the extrinsic losses are due to:

- transverse offset between fiber cores,

## THE DEVELOPMENT OF THE POTENTIAL AND ACADEMIC PROGRAMMES OF WROCLAW UNIVERSITY OF TECHNOLOGY

- fiber and separation,
- angular misalignment,
- nonsmooth end surface.

If about the splice techniques the most prominent one is the fusion splicing using electric arc or laser heating. The connectors however, are offered as the lens-coupled as well as butt-coupled (without lenses). Different types of butt-coupled connector e.g. screwed onto the optoelectronic transducer, modular style mounting system and for multi-contact strips etc. To decrease the contact losses the special index-matching liquid or epoxy can be used to fill the gap.

Another problem that influence the degradation of quality of the fiber optics transmission is dispersion. The dispersion is a collective term for all effects producing delay differences and therefore limiting the transmission bandwidth of the fiber. In MMFs dominates intermodal dispersion that is due to the differential time delay between modes at a single frequency. While, the intramodal (chromatic) results from the variation of group velocity of a particular mode with wavelength. It plays a significant role in SMFs as only one mode is propagating. The chromatic dispersion presents the combined effect of material and waveguide properties of the fiber string. However, the influence of the material dispersion is much higher with compare to this of the waveguide. In practice also the spectra source's width affects the overall dispersion thus the group delay time. As a result the bit rate ( $B_T$ ) as well as the bandwidth-length product ( $B_L \cdot L = \text{const}$ ) is limited, due to the total pulse spread (the dispersion coefficient is expressed both in terms of pulse spread and/or in terms of bandwidth). Quality of the optical fiber system transmission is strongly affected by the fotodetector properties. The good fotodetector should be among others:

- high in efficiency,
- sensitive and fast in response,
- low in noise,

Speed of response is limited by diffusion and drift time as well as by the junction capacitance. The total response time is also influenced by quality of the completed fotodetection system.

As a result to fulfill requirements if about the high transmission efficiency all the system elements and components should be carefully selected and matched to the wave length applied.

## 2. Investigations of the matching efficiency

Schematic diagram of the measuring system is shown in Fig.1.1. It is composed of the optical transmission unit, the frequency generator and the fotodetector unit with the output oscilloscope.

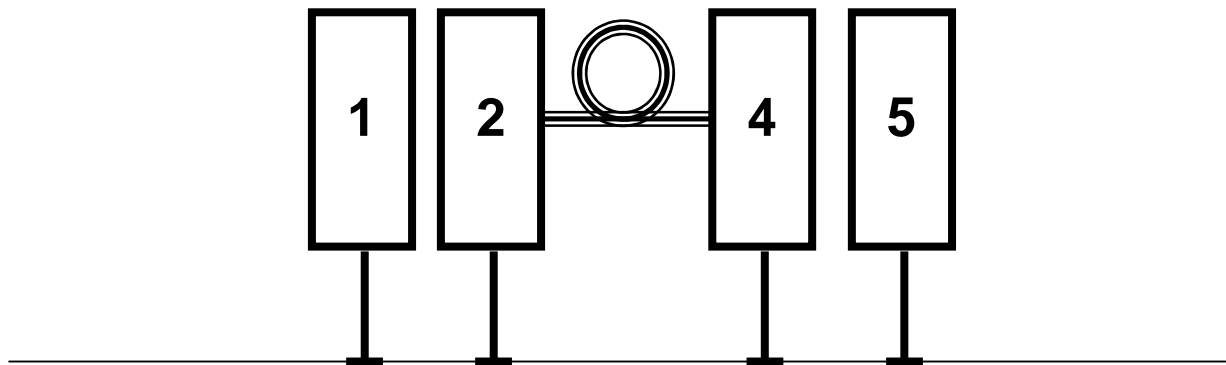

Fig.1.1. Block scheme of the testing circuit; 1. Electrical function generator, 2-4. Optical track based on ST standard connectors with gap measure equipment, 5. Oscilloscope.

### 2.1. Testing procedure

- power the optical transmission system together with the frequency generator and oscilloscope on,
- select required optical transmission system and set-up the air gap (between the fiber guide and connector) to its minimum value while, recording the received output pulses,
- adjust the gap length to its maximum value and control the output pulses respectively,
- test the output puls characteristic under variation of the gap length value from its minimum to maximum,
- repeat the measurements for different (selected in a whole range) frequencies,
- select another optical tract and repeat the whole test.

All the investigated data set-up in Table 1 and Table 2 and plot respective characteristics: dependence of the output pulse value (under the variable gap length between fiber guide and connector) on the fiber-connector distance and the time delay of the pulse versus frequency.



**THE DEVELOPMENT OF THE POTENTIAL AND ACADEMIC PROGRAMMES OF WROCLAW UNIVERSITY OF TECHNOLOGY**

Table 1. Output pulse value for different air gap length ( $f=5\text{kHz}=\text{const}$ )

No	l	U	U
[-]	[ $\mu\text{m}$ ]	[V]	[p.u.]
1.			
2.			

Table 2. Time delay of the output pulse as a function of frequency for fixed minimum ( $17\mu\text{m}$ ) gap length value

No	f	$t_{1(1)}$	$t_{2(1)}$	$\Delta t_{12(1)}$	$t_{1(0)}$	$t_{2(0)}$	$\Delta t_{12(0)}$
[-]	[kHz]	[ $\mu\text{s}$ ]	[ $\mu\text{s}$ ]	[ $\mu\text{s}$ ]	[ $\mu\text{s}$ ]	[ $\mu\text{s}$ ]	[ $\mu\text{s}$ ]
1.							
2.							

$t_{1(1)}$ -pulse rise time at input;  $t_{2(1)}$ -rise time at the output;

$t_{1(0)}$ - pulse fall time at input (generator);  $t_{2(0)}$ - fall time at the output.

Compare the obtained characteristics with the reference characteristics presented in Fig.2.1 ÷ Fig.2.3.

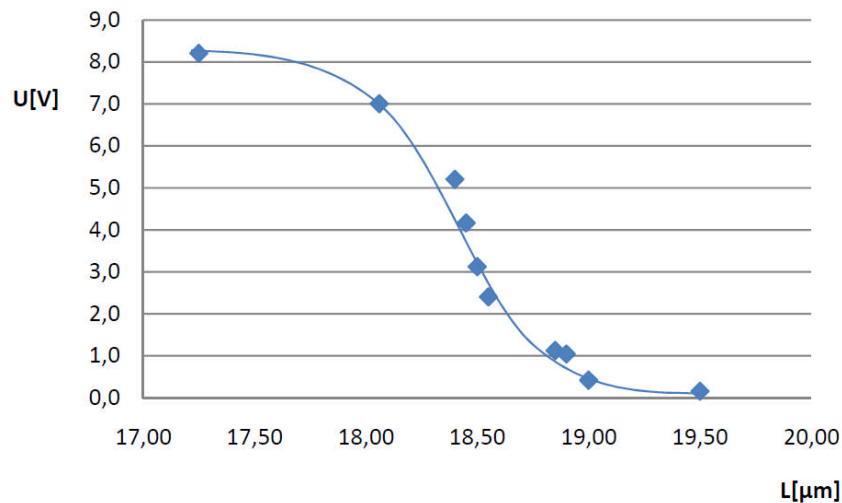

Fig.2.1. Output pulse value versus air gap length

**THE DEVELOPMENT OF THE POTENTIAL AND ACADEMIC PROGRAMMES OF WROCLAW UNIVERSITY OF TECHNOLOGY**

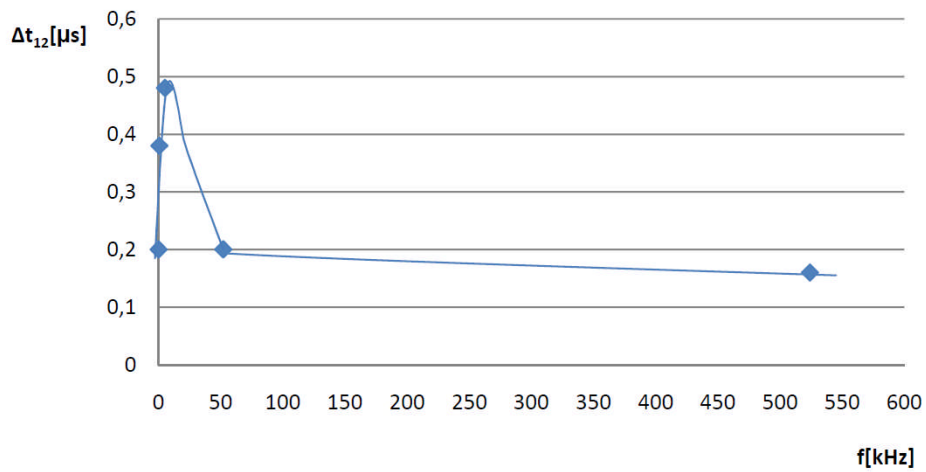

Fig.2.2. Variation of the difference time between the pulse rise time at input and output respectively when changing frequency

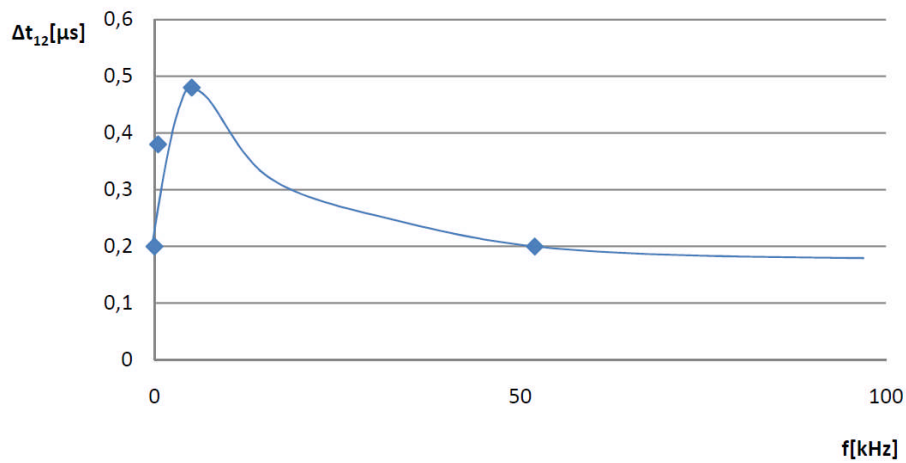

Fig.2.3. Selected area of characteristic from Fig.3

On the basis of the results specify respective conclusions.

## References

- [1] <http://en.wikipedia.org/wiki/Laser>
- [2] Chai Yeh: Handbook of Fiber Optics. Theory and Applications Academic Press Inc 2006.
- [3] CIGRE WORKING GROUP 35.04: Optical Fiber Cable Selection for Electricity Utilities; February 2001.
- [4] R.M. Gagbiardi, Sh. Karp: Optical Communications. Willey Interscience Publications 2007.