

Sample problems to solve

1. Numerical method of Adams-Bashforth for solving of differential equations:

$$\frac{dy(t)}{dt} = f(y, t)$$

has the form:

$$y(k) = y(k-1) + \frac{T}{2}(3f(y(k), t_k) - f(y(k-1), t_{k-1})).$$

Using this method determine the companion numerical models of:

- inductance
- capacitance
- in series connected RL .

2. Determine the equivalent numerical models corresponding to the trapezoidal integration method used for models of the particular components in the following branches (Fig. 1):

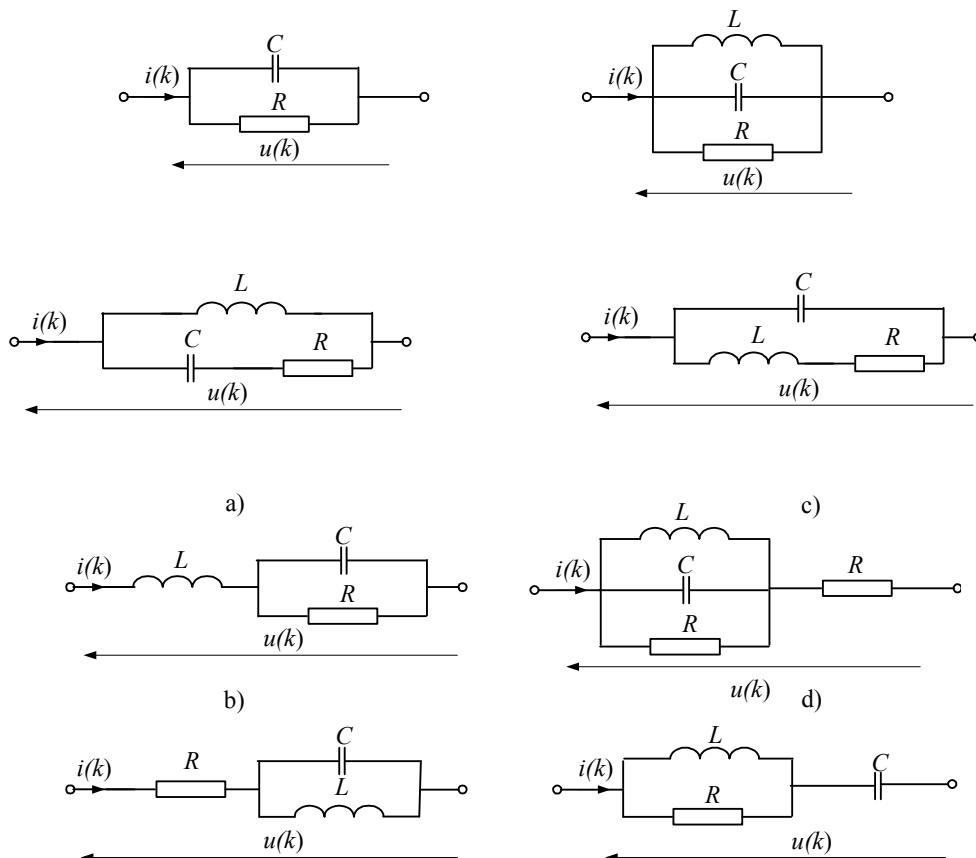

Fig.1

Repeat solution for Euler's implicit method of approximation.

3. Using the basic Bergeron's model derive the model of the lossless long line shown in Fig.2.

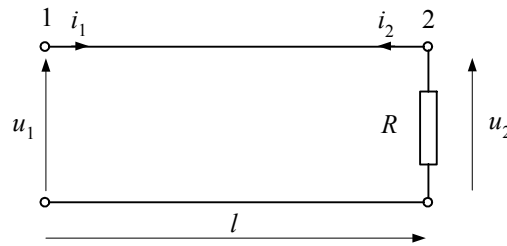

Fig.2

Applying the derived model of this line when find the models for particular cases in which:

- the end of the line is open ($R = \infty$)
- the end of the line is short-circuited ($R = 0$)

4. Consider the lossless line shown in Fig.3 for which the basic per unit parameters and the length l are, respectively:

$$C' = 0.16 \mu\text{F/km}, \quad L' = 0.4\text{mH/km}, \quad l = 32\text{km}.$$

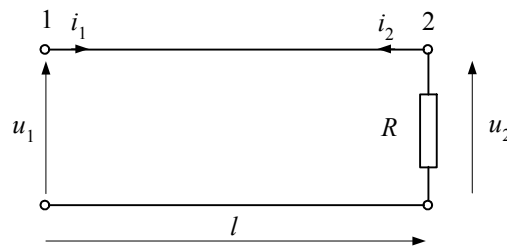

Fig.3

Using the basic Bergeron's long line model calculate the first 6 samples ($k = 0 \div 5$) of currents $i_1(k)$ and $i_2(k)$ for $R = 2Z_f$. Assume that calculation step $T = 0.25\text{ms}$ and the constant excitation $u_1(k) = 300\text{V}$ appears at $k = 0$.

$$i_1(k) = G_f u_1(k) - G_f u_2(k - m) - i_2(k - m),$$

$$i_2(k) = G_f u_2(k) - G_f u_1(k - m) - i_1(k - m),$$

$$m = \frac{\tau}{T} = \frac{l}{vT} \quad v = \frac{1}{\sqrt{L'C'}} \quad Z_f = \sqrt{\frac{L'}{C'}} \quad G_f = \frac{1}{Z_f}$$

5. Show the state space representation of each circuit shown in Fig.1 a, b, c, d. In each case the output variables are: the current flowing through the capacitor C , voltage drop across the inductor L and current flowing through the resistors R .