



HUMAN CAPITAL
NATIONAL COHESION STRATEGY



Wrocław University of Technology

EUROPEAN UNION
EUROPEAN
SOCIAL FUND



THE DEVELOPMENT OF THE POTENTIAL AND ACADEMIC PROGRAMMES OF WROCLAW UNIVERSITY OF TECHNOLOGY

BOGDAN MIEDZIŃSKI, WITOLD DZIERŻANOWSKI,
GRZEGORZ WIŚNIEWSKI, MARCIN HABRYCH

POWER SYSTEM PROTECTION

TEXT BOOK

WROCLAW UNIVERSITY OF TECHNOLOGY

WROCLAW, 2010

THE DEVELOPMENT OF THE POTENTIAL AND ACADEMIC PROGRAMMES OF WROCLAW UNIVERSITY OF TECHNOLOGY

CONTENTS

EXAMINATIONS OF CURRENT TRANSFORMERS	4
1. Introduction	4
2. Measurement procedure	10
2.1. Checking of CT terminals	10
2.2. Transformation (turn) ratio	10
2.3. Determination of $n_{w10}=f(Z_T)$ relationship	12
INVESTIGATION OF ZERO-SEQUENCE CURRENT FILTERS	13
1. Introduction	13
2. Investigation of zero-sequence current filters	17
2.1. Residual (Holmgreen) CT connection	17
2.1.1. Error current measurement	17
2.1.2. Estimation of high harmonic content of the residual current	20
2.2. Core balance (Ferranti) transformer	20
2.2.1. Derivation of magnetizing characteristic	20
2.2.2. Error (residual) current measurements	21
2.2.3. Measurement of the current ratio of the Ferranti CT	22
2.2.4. Inspection of CT windings and relay impedance	22
INVESTIGATION OF SINGLE INPUT RELAYS	23
1. Introduction	23
2. Over-current relays and their characteristics	24
2.1. Time-over-current electromechanical relay R _{Iz}	27
2.2. Digital MiCOM P211 protection for electrical motors	28
2.3. Investigations procedures	32
TASK No 3 – investigation of inverse time over current relays	33
1. Functional tests: operate and release current value	33
2. Inverse time (dependent) characteristics	34
TASK No 4 – investigation of instantaneous and definite time relays	35
1. Operate and release values	35
INVESTIGATION OF DIRECTIONAL RELAYS	36
1. Applicability of directional relays	36
2. Principle of operation and basic characteristics of directional relays	37
3. Test and measurement procedures	44
3.1. Evaluation of relay characteristic angle (RCA)	44
3.2. Evaluation of characteristic $U_{op}=f(I)$ and $S_{op}=f(I)$	46
3.3. Testing requirements for MiCOM P127 relay	47
3.3.1. Basic information	47
3.3.2. Connection of MiCOM P127 as overcurrent directional relay	47
3.3.4. Test and measurement procedure	48
INVESTIGATION OF DIFFERENTIAL RELAYS	50
1. Introduction – differential principle	50
2. Examination of electromechanical differential relays	56

THE DEVELOPMENT OF THE POTENTIAL AND ACADEMIC PROGRAMMES OF WROCLAW UNIVERSITY OF TECHNOLOGY

2.1. Laboratory stand	56
2.2. Selected differential relays	57
2.2.1. Electromechanical relay RQS-2 type	57
2.2.2. Electromechanical relay TG-3 type	58
2.2.3. Microprocessor based relay (MiCOM P631 – AREVA).....	59
2.3. Method of testing.....	64
2.3.1. Verification of scale of current-carrying capacity of a relay	65
2.3.2. Derivation of operation characteristics $I_{op}=f(I_n)$	65
INVESTIGATION OF DISTANCE RELAYS	67
1. Introduction	67
1.1. General information	67
1.2. Structure and characteristics of the distance relays	69
1.2.1. General structure	69
1.2.2. Operational threshold sensing unit	70
1.2.3. Measuring unit.....	72
1.2.4. Directional sensitive element	73
1.2.5. Timing unit	74
2. Investigation of distance relays	75
2.1. Electromechanical relay type R1KZ4	75
2.1.1. Structure, principle of operation and basic parameters	75
2.1.2. Setting of the R1KZ4 relay.....	77
2.1.3. Circuit for laboratory testing	78
2.1.4. Determination of the impedance circular characteristic	78
2.1.5. Determination of the time-impedance dependent characteristic	80
2.2. Microprocessor based distance relay	80
2.2.1. Investigation procedure	81
ACCEPTANCE AND RELIABILITY COMPLIANCE TEST AND SETTING OF GENERATOR PROTECTION	82
1. Introduction	82
2. Protection systems of synchronous generator	83
3. Particular protection and its setting	86
3.1. Stabilized current differential protection (longitudinal)	86
3.2. Stator ground-fault protection.....	86
3.3. Protection of single ground fault in the rotor	86
3.4. Overload protection	87
3.5. Back-up protection from harm caused by external faults	87
3.6. Field forcing.....	88
4. Investigation of the generator protections	88
4.1. Laboratory test stand.....	88
4.2. Goal and range of the test	89



TASK No 1

EXAMINATIONS OF CURRENT TRANSFORMERS

Concise specification (manual)

1. Introduction

Current transformer represents an electrical device intended to limit primary current to secondary current of value convenient to supply metering and/or protection equipment.

Advantages

- a) separation of meters and relays from high voltage level supply,
- b) transformation of primary current to values convenient for measurement what limits numbers of standard values of rated secondary current.

Schematic diagram of a current transformer is shown in Fig 1. Terminals of primary winding are denoted by capital letters **K** and **L** while these of secondary – small letters **k** and **l** respectively (now **P1**, **P2** and **S1**, **S2**).

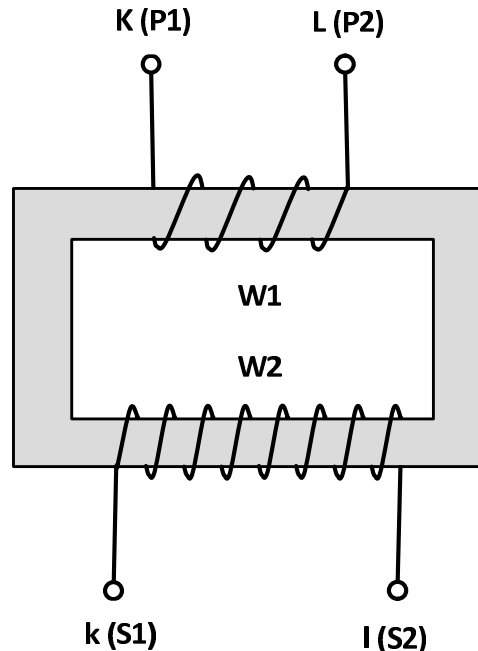

Fig. 1. Schematic diagram of a current transformer

Current transformer is loaded with constant burden (Z) and its secondary current I_s is related to primary I_p value with turns ratio (transformer ratio) \mathfrak{D}_i that is real number:



THE DEVELOPMENT OF THE POTENTIAL AND ACADEMIC PROGRAMMES OF WROCLAW UNIVERSITY OF TECHNOLOGY

$$g_i = \frac{I_p}{I_s} \quad (1)$$

To analyze phenomena in current transformer under various condition it is convenient to represent it by equivalent circuit that transferred to secondary winding is illustrated in Fig 2. In this circuit primary quantities are transferred to secondary winding as follow:

$$I'_p = I_p \frac{W_1}{W_2} \quad (2)$$

$$I'_m = I_m \frac{W_1}{W_2} \quad (3)$$

where: W_1, W_2 – number of turns of primary and secondary winding respectively.

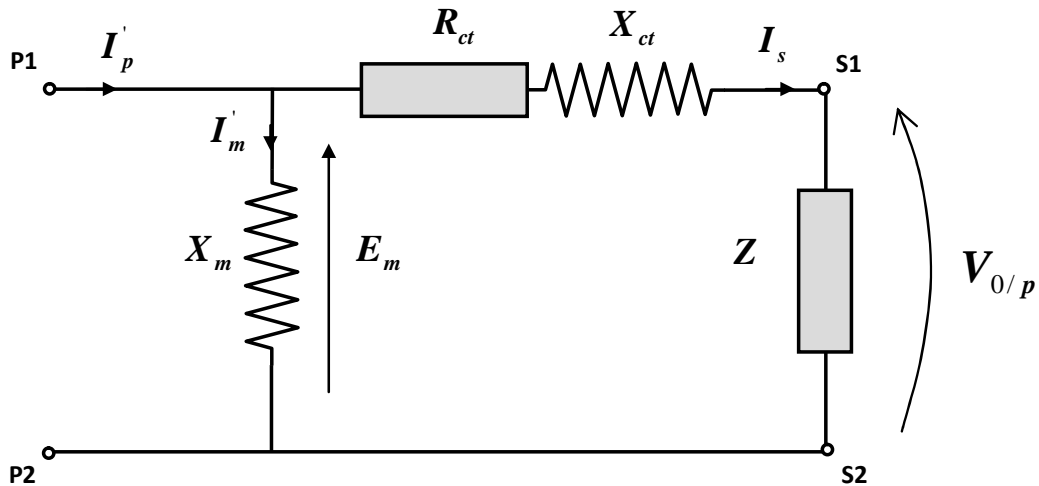

Fig. 2. Simplified equivalent scheme of current transformer

Basic technical data specified (in data plate) are as follows:

- rated primary current value in A,
- rated secondary current value in A,
- rated burden (apparent power) in VA,
- accuracy class in %,
- rated accuracy limit factor (ALF),
- rated insulation voltage in kV.

Rated both primary I_{pr} and secondary current I_{sr} are standardized. Standard values of secondary currents are: 1A, 2A, 5A, preferred value is 5A.



THE DEVELOPMENT OF THE POTENTIAL AND ACADEMIC PROGRAMMES OF WROCLAW UNIVERSITY OF TECHNOLOGY

Rated burden (output) of the current transformer is defined by apparent power S_r (at rated current value and inductive power factor $\cos\varphi=0.8$) for which accuracy class is not failed.

$$S_r = I_{sr}^2 Z_r \quad (4)$$

Accuracy class for protection current transformers CTs defines limits of errors (current phase and composite error respectively) and is indicated by **P** letter e.g. 5P, 10P.

Current error ΔI – results from difference in magnitude of currents (real turn ratio \mathfrak{G}_i differs from rated value \mathfrak{G}_{ir}). It is expressed at percentage of rated current as follows:

$$\Delta I = \frac{\mathfrak{G}_{ir} I_s - I_p}{I_p} \cdot 100 \quad (5)$$

where: $\mathfrak{G}_{ir} = \frac{I_{pr}}{I_{sr}}$

I_{pr} , I_{sr} – rated primary and secondary currents respectively.

Phase error – angle Θ between vectors of primary and secondary current, usually is expressed in minutes or centiradians. Its positive value (sign +) indicates that primary current vector leads its of secondary.

Composite error ΔI_w – rms value (in steady state) of the difference between instantaneous values of currents calculated as below:

$$\Delta I_w = \frac{100}{I_p} \sqrt{\frac{1}{T} \int_0^T (\mathfrak{G}_{ir} i_s - i_p)^2 dt} \quad (6)$$

where: i_p , i_s – instantaneous values of primary and secondary current respectively,
 T – period,
 \mathfrak{G}_{ir} – rated turn ratio.

For sinusoidal currents it can be expressed as:

$$\Delta I_w = \frac{|\mathfrak{G}_{ir} I_s - I_p|}{I_p} \cdot 100 \% \quad (7)$$

Errors of a current transformer depends on magnetizing current I_m that is absorbed by the CT core (magnetizing impedance X_m is nonlinear). If the CT will saturate (for exceeded I_m value), secondary output is lost and transformer's errors increase – as a result. However, for small I_m value the errors also tend to increase due to decreased magnetizing impedance X_m that shunts the burden. As a matter of fact, error values depends on the burden, there is



THE DEVELOPMENT OF THE POTENTIAL AND ACADEMIC PROGRAMMES OF WROCLAW UNIVERSITY OF TECHNOLOGY

maximum limit to the output voltage $V_{0/p}$ (see Fig 2) which the CT can produce. In Fig 4 one can see dependence of secondary current I_s value on primary current I_p for different burden and different power factor ($\cos\phi_s$) of secondary circuit of the CT.

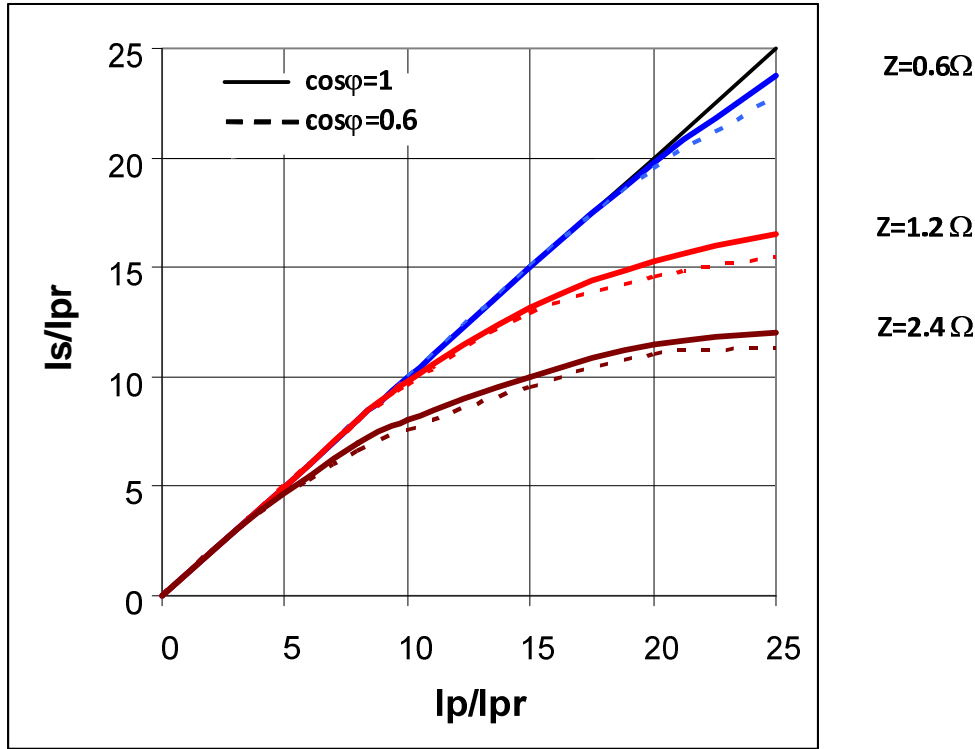

Fig. 3. Variation of the secondary current I_s value on primary current I_p : a) for constant burden, b) for different burden value

For protection CTs the composite error is defined for maximum rated primary current I_{pMAX} calculated with use of accuracy limit factor $ALF (n_{wr})$:

$$I_{pMAX} = n_{wr} I_{pr} \tag{8}$$

Accuracy limit factor (n_{wr}) gives maximum current which CT can supply it's rated burden ($pf \approx 0.8\div 1$ inductive) before it saturates. It is multiple of rated current up to which stated accuracy class is maintained. Standard values: 5 – 10 – 15 – 20 – 30. From CT magnetization characteristic it is clear that ALF value is strongly related to output burden value. For the given rated n_{wr} value and given load impedance (burden) Z respective ALF (n_w) can be calculated from formula:

$$n_w \approx n_{wr} \frac{Z_{CT} + Z_r}{Z_{CT} + Z} \tag{9}$$

where: Z_{CT} – impedance of secondary circuit of CT (see Fig 2).



THE DEVELOPMENT OF THE POTENTIAL AND ACADEMIC PROGRAMMES OF WROCLAW UNIVERSITY OF TECHNOLOGY

The **ALF** (n_w) indicates hyperbolic relation to the burden (Z) in practice as illustrated in Fig 4.

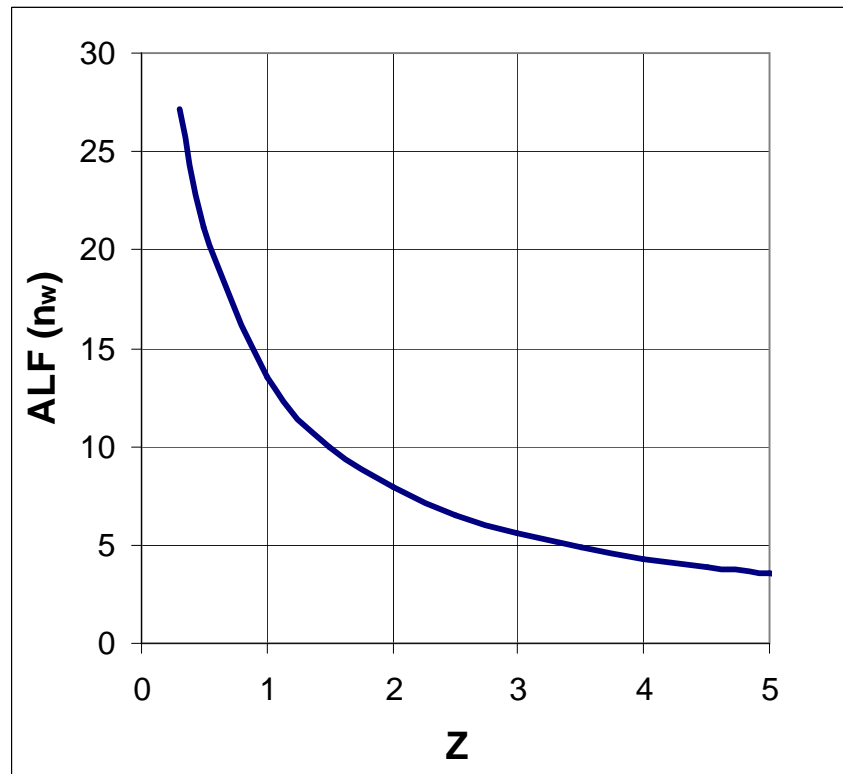

Fig. 4. ALF value versus output burden (Z) of the CT

Methods of determination of ALF value

According to Standards both composite error and ALF value have to be determined in direct way. For selected current transformers (e.g. for uniform, toroidal core) some indirect methods are acceptable. However, the direct way is the most precise since allow for reproduction of real conditions of operation but it requires high power of the supplying source. Sometimes, overheating of the CT windings can be a hazard. Therefore, in labs (particularly for demonstrations) the indirect methods are mostly used. Below only the method that employs CT magnetization characteristic is presented.



THE DEVELOPMENT OF THE POTENTIAL AND ACADEMIC PROGRAMMES OF WROCLAW UNIVERSITY OF TECHNOLOGY

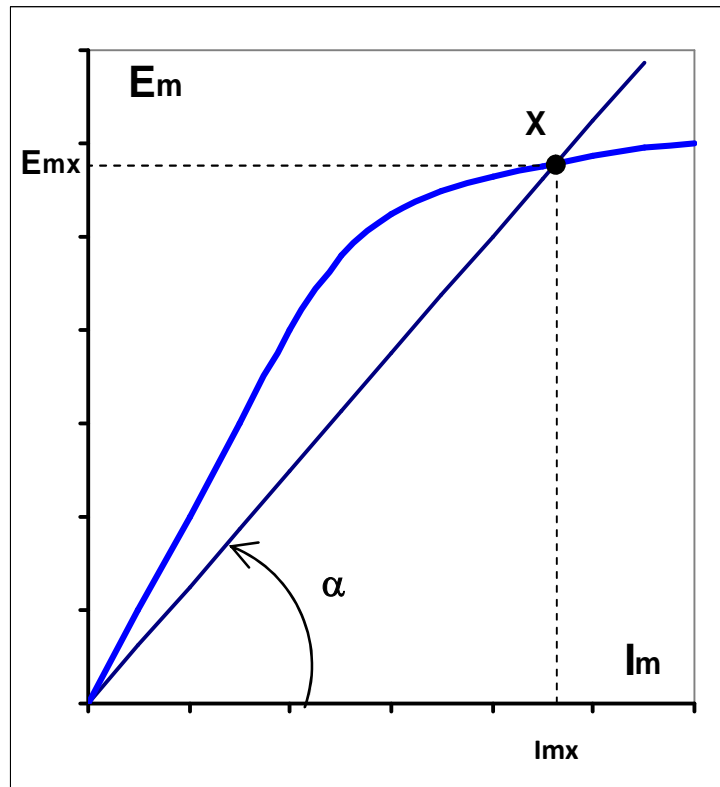

Fig. 5. Illustration for the ALF determination

For the given CT magnetization characteristic $E_m=f(I_m)$ as in Fig 5 one has to fix point x for which:

$$I_{mx} = 0.1I'_p \quad (10)$$

Assume, for simplicity, that the primary and secondary currents are in phase, we have:

$$I_{sx} = I'_p - I_{mx} = 0.9I'_p \quad (11)$$

Therefore, from equivalent circuit shown in Fig 2 one can write that:

$$E_m = I_s(Z_{CT} + Z) = I_s Z_T \quad (12)$$

where: Z_T – resultant impedance (burden) of the secondary circuit of the CT.

Taking into account equation (11), for the given I_{sx} current, voltage E_{mx} across magnetizing impedance X_m is equal:

$$E_{mx} = 0.9I'_p Z_T \quad (13)$$

It gives the point x of intersection of the magnetization characteristic with a straight line erected from beginning of coordinate system under angle α (see Fig 5). According to equations (10) and (13) it gives:

THE DEVELOPMENT OF THE POTENTIAL AND ACADEMIC PROGRAMMES OF WROCLAW UNIVERSITY OF TECHNOLOGY

$$\tan \alpha = k_s \frac{E_{mx}}{I_{mx}} = k_s \frac{0.9I'_p Z_T}{0.1I'_p} = 9k_s Z_T \quad (14)$$

where: k_s – scale factor (for the same scale axes for E_m and I_m , $k_s=1$).

Having defined E_{mx} value the ALF coefficient can be calculated from formula:

$$n_w = \frac{I'_p}{I'_{pr}} = \frac{E_{mx}}{0.9Z_T} \cdot \frac{1}{I'_{pr}} \quad (15)$$

It is approximate value since $\tan \alpha$ does not fulfill equation (13) in practice and usually is in the range from $7.2k_s Z_T$ to $9 k_s Z_T$ respectively. Therefore usually, ALF value is higher from this of calculation.

2. Measurement procedure

2.1. Checking of CT terminals

Circuit for checking the terminals marking is shown in Fig 6.

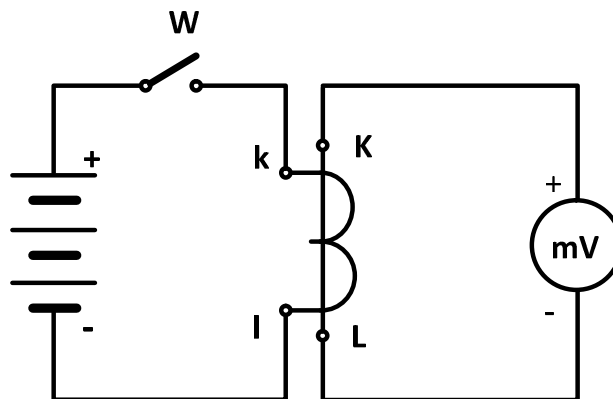

Fig. 6. Test circuit for the determination of CT terminals

For correct notation of the terminals at a moment of closure of switch (W) the voltmeter should indicate right swing of a pointer while, under opening – reverse, respectively.

2.2. Transformation (turn) ratio

After having checked the turn ratio one can detect possible short circuits of turns in windings as well as wrong notation of the current transformer. However, it can not be considered as checking of the CT accuracy (this must be accomplished by means of



THE DEVELOPMENT OF THE POTENTIAL AND ACADEMIC PROGRAMMES OF WROCLAW UNIVERSITY OF TECHNOLOGY

compensation method). Circuit for checking the transformation ratio of the CTs of a small \mathcal{G}_i (e.g. 10/5) is shown in Fig 7.

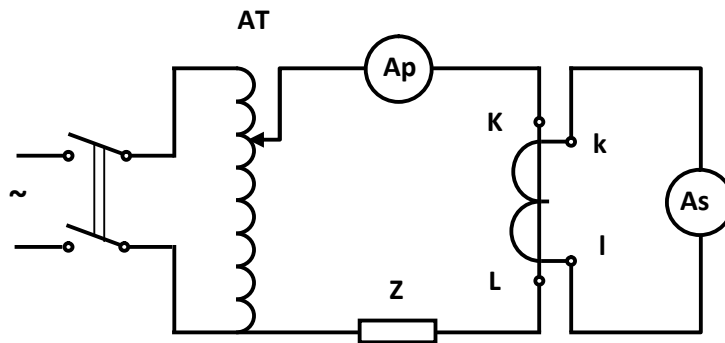

Fig. 7. Circuit for the measurement of transformation ratio

Measurements have to be conducted for primary current ranged from $0.1I_{pr}$ to $1.2I_{pr}$ (rated primary current) value.

The investigated results (I_s , I_p and calculated \mathcal{G}_i) must be specified in Table.

2.2. Magnetization characteristic

On the basis of measurements of the magnetization characteristic one can easily detect short circuits of turns in windings (if compare with reference characteristic of another CT in differential measuring system) and/or define ALF value as well. Schematic diagram for the measurement of the CTs magnetization characteristic is shown in Fig 8.

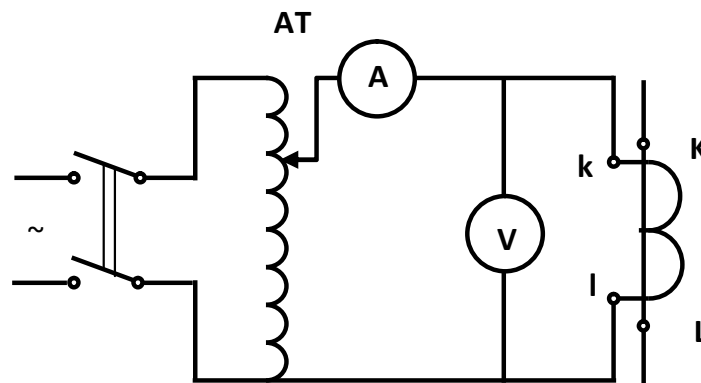

Fig. 8. Typical circuit for the measurement of CTs magnetization characteristic

Since magnetization impedance is nonlinear therefore some deformations of the current can be produced. Therefore, under the measurements meters of mean values (instead of rms) must be used (e.g. magnetolectric with rectifier or another equivalent electronic). Current must be ranged from 0 up to $1.2I_{sr}$.

THE DEVELOPMENT OF THE POTENTIAL AND ACADEMIC PROGRAMMES OF WROCLAW UNIVERSITY OF TECHNOLOGY

One has to take into account that to plot a magnetization curve, both core cross-sectional area, mean length of magnetic path as well as number of secondary turns should be known. Having known, the above parameters the flux density (**B**) versus magnetizing force (**H**) can easily be achieved.

2.3. Determination of $n_{w10}=f(Z_T)$ relationship

Having measured the magnetization characteristic for selected CT one has to plot straight lines of slope defined according to equation (14) for different Z_T value in the range from $Z_T=Z_{CT}$ (shorted output terminals) up to $Z_T=Z_{CT}+4Z_r$. Intersection point of the straight evaluates value of magnetizing current I'_{m10} equal to 10% of the primary current for particular loading.

Accuracy limit factor thus can be obtained (for particular load selected) according to equation (15). Typical $n_w=f(Z)$ curve is demonstrated for example in Fig 4.



TASK No 2

INVESTIGATION OF ZERO-SEQUENCE CURRENT FILTERS

Concise specification (manual)

1. Introduction

The method of symmetrical components that was discovered at the beginning of the 20th century provides a practical technology for understanding and analyzing unbalanced conditions of a power system. Many protective relays operate from these components quantities to detect those by such as faults between phases and ground, open phases, unbalanced impedances etc.

Any unbalanced current or voltage can be derived from the sequence components (positive, negative and zero) given in the basic equations as follows:

$$\left. \begin{aligned} \underline{I}_A &= \underline{I}_1 + \underline{I}_2 + \underline{I}_0 \\ \underline{I}_B &= a^2 \underline{I}_1 + a \underline{I}_2 + \underline{I}_0 \\ \underline{I}_C &= a \underline{I}_1 + a^2 \underline{I}_2 + \underline{I}_0 \end{aligned} \right\} \quad (1)$$

$$\left. \begin{aligned} \underline{U}_A &= \underline{U}_1 + \underline{U}_2 + \underline{U}_0 \\ \underline{U}_B &= a^2 \underline{U}_1 + a \underline{U}_2 + \underline{U}_0 \\ \underline{U}_C &= a \underline{U}_1 + a^2 \underline{U}_2 + \underline{U}_0 \end{aligned} \right\} \quad (2)$$

where: currents (\underline{I}_A , \underline{I}_B , \underline{I}_C) and voltages (\underline{U}_A , \underline{U}_B , \underline{U}_C) represent unbalanced line-to-neutral phasor while \underline{I}_1 , \underline{I}_2 , \underline{I}_0 and \underline{U}_1 , \underline{U}_2 , \underline{U}_0 are positive, negative and zero-sequence components respectively.

$$\begin{aligned} \underline{I}_0 &= \frac{1}{3}(\underline{I}_A + \underline{I}_B + \underline{I}_C), & \underline{U}_0 &= \frac{1}{3}(\underline{U}_A + \underline{U}_B + \underline{U}_C) \\ \underline{I}_1 &= \frac{1}{3}(\underline{I}_A + a \underline{I}_B + a^2 \underline{I}_C), & \underline{U}_1 &= \frac{1}{3}(\underline{U}_A + a \underline{U}_B + a^2 \underline{U}_C) \\ \underline{I}_2 &= \frac{1}{3}(\underline{I}_A + a^2 \underline{I}_B + a \underline{I}_C), & \underline{U}_2 &= \frac{1}{3}(\underline{U}_A + a^2 \underline{U}_B + a \underline{U}_C) \end{aligned} \quad (3)$$

Zero sequence currents and voltages occur as the result of an earth fault on the system (see Fig 1 and Fig 2).

The residual connections (Holmgreen system) does not provide neither high current sensitivity or selectivity. Its main disadvantages are due to the following facts namely:



THE DEVELOPMENT OF THE POTENTIAL AND ACADEMIC PROGRAMMES OF WROCLAW UNIVERSITY OF TECHNOLOGY

- phase faults or transformer magnetizing inrush can produce “spill” current due to CTs mismatch what result in spurious operation if the relay setting is exceeded,
- line CTs are generally rated to match load currents therefore, it is difficult to detect small current values.

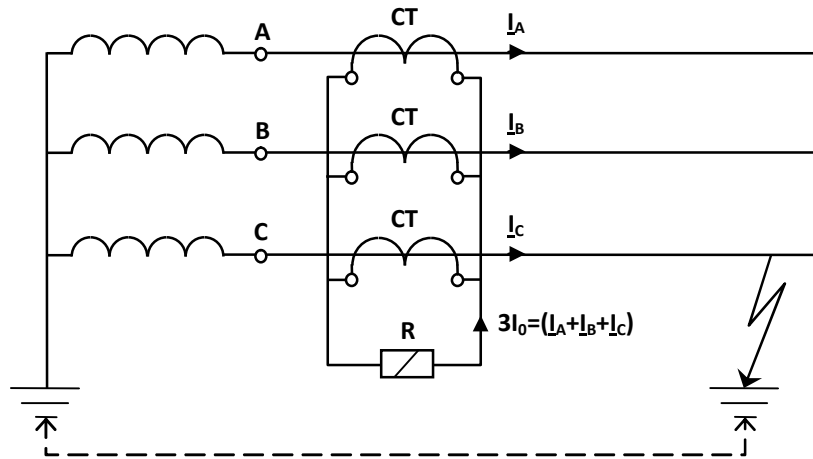

Fig. 1. Principle of residual (Holmgreen) CT connection (CTs – line current transformers)

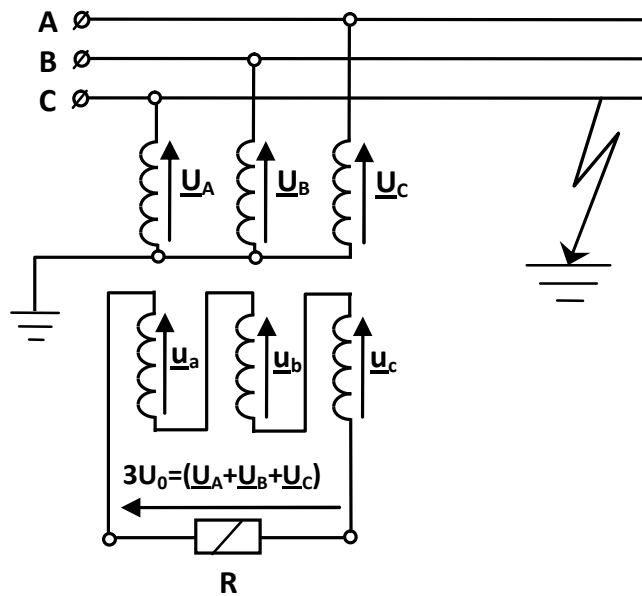

Fig. 2. Connections of voltage transformer to detect zero-sequence voltage component (a neutral voltage displacement)

Therefore, the Holmgreen system (Fig 3) (residual connection of the line current transformers) cannot be used where sensitive earth fault setting is required.

THE DEVELOPMENT OF THE POTENTIAL AND ACADEMIC PROGRAMMES OF WROCLAW UNIVERSITY OF TECHNOLOGY

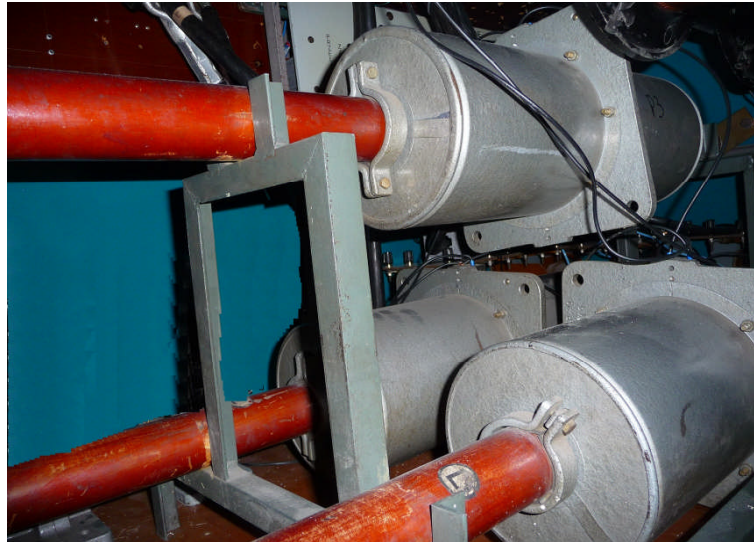

Fig. 3. Lab model of the Holmgren system

Much more useful is protection (particularly at the lower current and voltage) is a flux summation current transformer known also as a core balance or Ferranti CTs. It consists of a magnetic core with a distributed winding. Power conductors (cables) are passed through the center opening as indicated in Fig 4 and Fig 5. The advantages are that there is no problem due to “spil” current and that turn ration does not need to be related to the load current or kVA of the circuit. It avoids the possible difficulties of unequal individual CT saturation or performance with parallels CTs. The disadvantage is the limitation of the size of cable that can be passed through the opening.

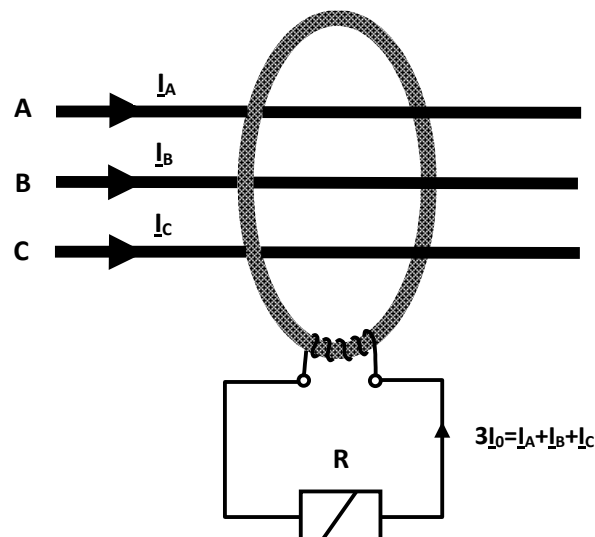

Fig. 4. Idea of the core balance current transformer (R – ground fault relay)

THE DEVELOPMENT OF THE POTENTIAL AND ACADEMIC PROGRAMMES OF WROCLAW UNIVERSITY OF TECHNOLOGY

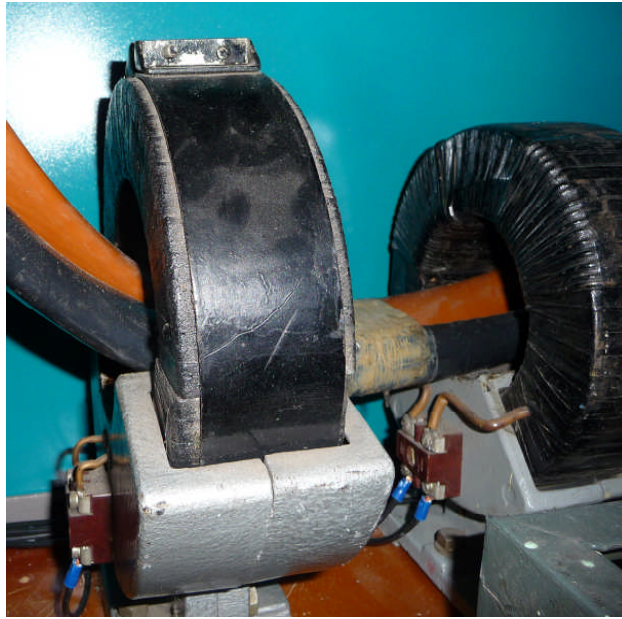

Fig. 5. Lab model of Ferranti CTs

Please note that when the core balance CT is located external to cable box a screen earth connection should be passed back through the CT opening as indicated in Fig 6a.

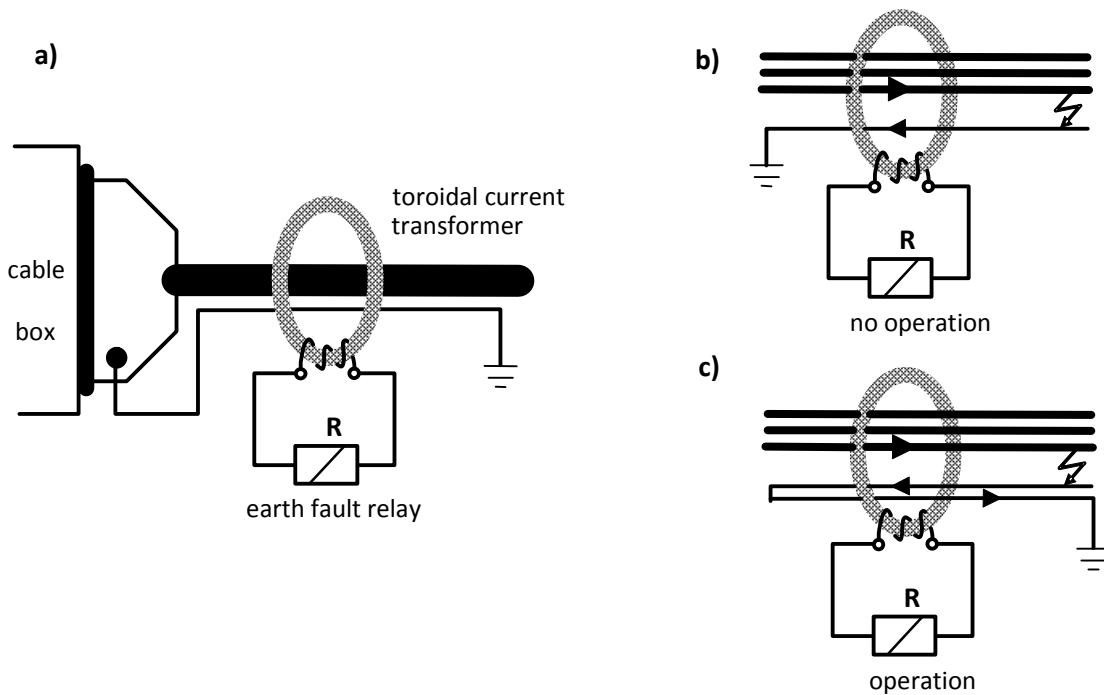

Fig 6. Typical application of the core balance (Ferranti) current transformer for ground fault protection with metallic sheath conductors

THE DEVELOPMENT OF THE POTENTIAL AND ACADEMIC PROGRAMMES OF WROCLAW UNIVERSITY OF TECHNOLOGY

Otherwise, the metallic sheath or shielded cables passed through the toroidal CT can result either in incorrect operation under influence of stray currents in the sheath or in cancellation of the fault current (Fig 6b).

Zero sequence voltage U_0 is provided from voltage transformers (VT's) set connected as in Fig 2. It must be either 3 single phase VT's or 5-limb voltage transformer. Residual voltage (U_0), or in another words neutral voltage displacement, is obtained from open delta secondary windings. However, the VT primary must be earthed.

To detect presence of earth the different protection systems are being used basing on measurements of the zero sequence current I_0 and voltage U_0 and/or their combinations. Therefore depending on requirements there are in use following ground fault protections:

- over-voltage (U_0),
- over-current (I_0),
- directional of active and reactive characteristics,
- zero sequence admittance, conductance and susceptance.

Since odd harmonics of the ground-fault current (with domination of the third one) are also zero sequence quantities therefore, protections employed either maximum lever of the harmonics or ratio of selected harmonic to the basic one as a fault threshold are also found in practice.

2. Investigation of zero-sequence current filters

2.1. Residual (Holmgreen) CT connection

2.1.1. Error current measurement

Circuit for valuation of the current errors of the residual (Holmgreen) CTs connection is illustrated in Fig 7. The measurements are carried out for different current value I_{load} of primary CTs windings: (0.1, 0.25, 0.50, 0.75, 1.0, 1.25 and 1.5) $\times I_n$ (where: I_n – rated primary current) as well as a few loading resistance value of secondary CTs (R_{p1} , R_{p2} , R_{p3}).



THE DEVELOPMENT OF THE POTENTIAL AND ACADEMIC PROGRAMMES OF WROCLAW UNIVERSITY OF TECHNOLOGY

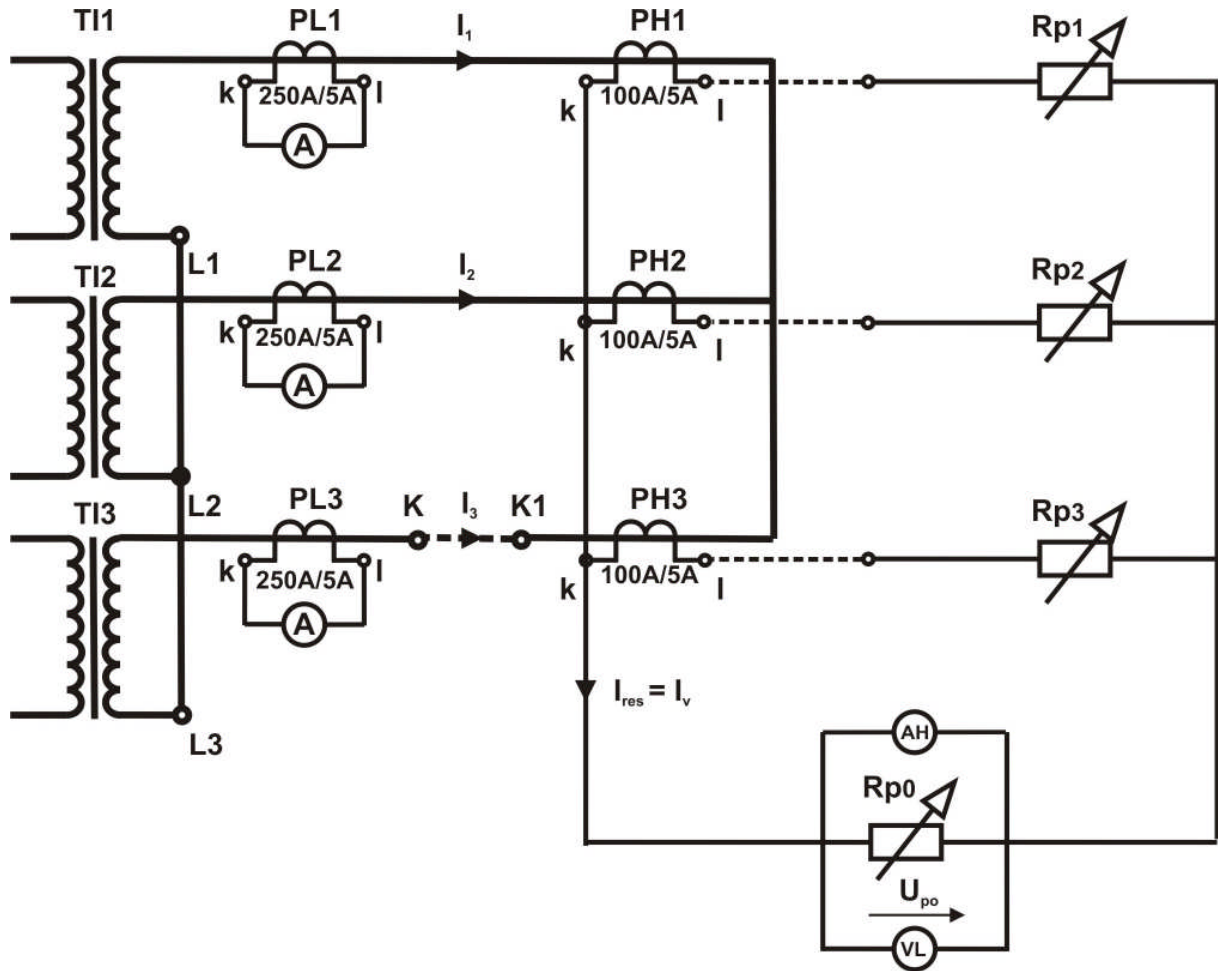

Fig. 7. Diagram of electric circuit for errors current measurement of the residual CTs connection; TI1...TI3 – supplying transformers, PL1...PL3 – measuring current transformers, PH1...PH3 – line transformers of the Holmgreen system, AH – harmonics analyzer, VL – electronic voltmeter.

The resistance R_{p0} of the return conductor is to be selected also. Particular resistors setting as well as connection of the CTs is performed on the face panel of the lab stand (see Fig 8).

THE DEVELOPMENT OF THE POTENTIAL AND ACADEMIC PROGRAMMES OF WROCLAW UNIVERSITY OF TECHNOLOGY

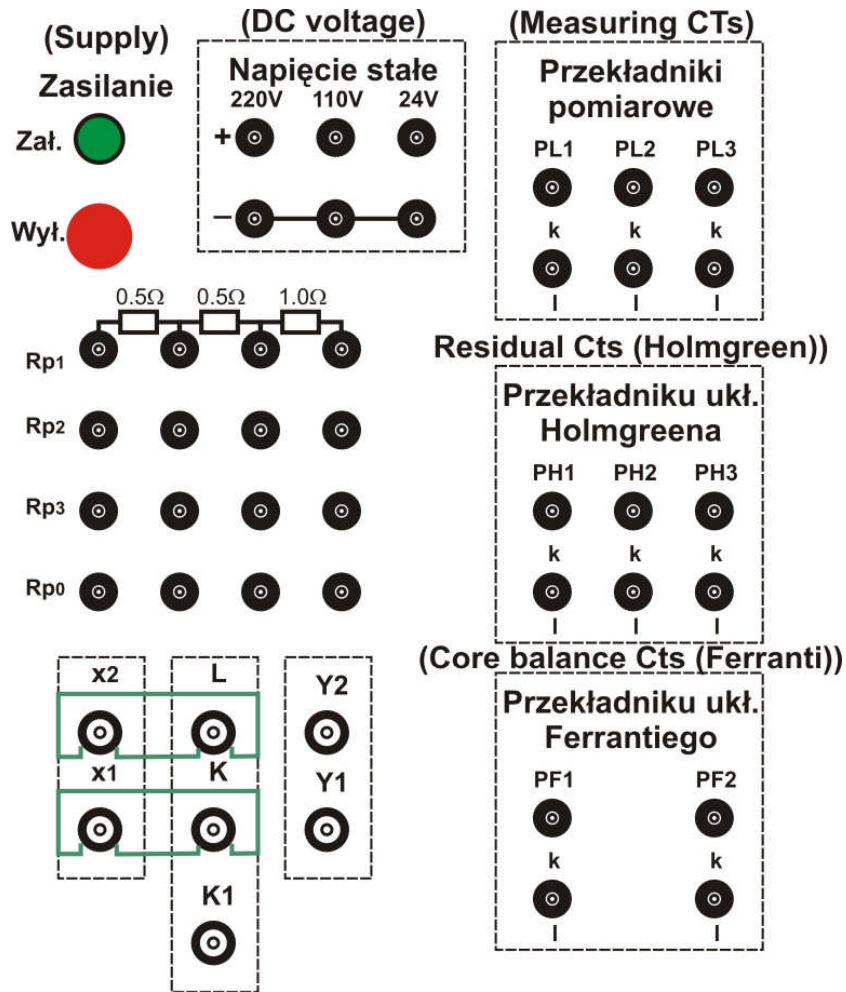

Fig. 8. View of the face panel for setting and connections

The error (residual) current value ($I_{res}=I_v$) (due to simulated CTs secondary mismatching) is estimated by measurement of the voltage drop across R_{po} resistance (Fig 7):

$$I_{res} = I_v = \frac{U_{po}}{R_{po}} \quad (4)$$

The result must be tabulated (in Table 1), and respective conclusions on relationship between the current error and loading current as well as resistance values should be formulated.

Table 1. Residual current value and high harmonic content

Lp	I_{load}	R_p	R_{po}	U_{po}	Error (residual) current											
					I_v		I1		I2		I3		I5		I7	
					A	%	A	%	A	%	A	%	A	%		
1																
2																

THE DEVELOPMENT OF THE POTENTIAL AND ACADEMIC PROGRAMMES OF WROCLAW UNIVERSITY OF TECHNOLOGY

2.1.2. Estimation of high harmonic content of the residual current

The measurements are carried out in the same circuit (presented in Fig 7) with the use of selective harmonics analyzer. For the simulated conditions of operation of the Holmgreen system one has to measure the residual (error) current value ($I_{res}=I_v$) and estimate values of both first and higher order harmonics (values should be calculated in miliamperes and set-up in Table 1).

2.2. Core balance (Ferranti) transformer

2.2.1. Derivation of magnetizing characteristic

Typical circuit for measuring of the magnetizing characteristics expressed in voltage and current values ($E_{(2)}=f(I'_\mu)$) is shown in Fig 9.

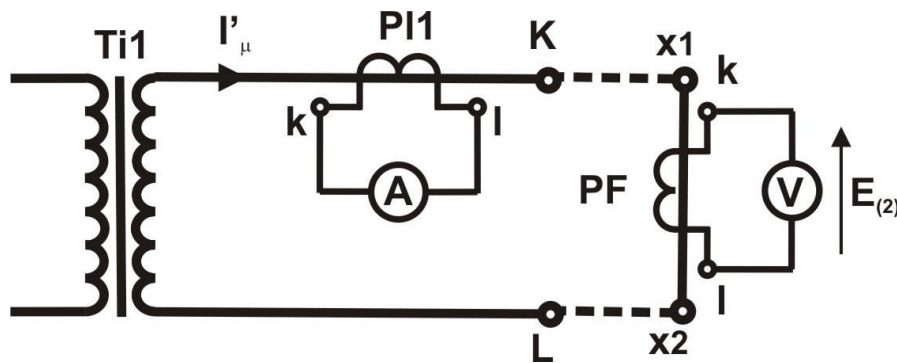

Fig. 9. Circuit for derivation of voltage-current, magnetizing characteristic of the Ferranti CT (PF – core balance CT, PL3 – measuring CT)

To set-up suitable measuring conditions one has to change terminal configuration on the face panel and connect directly X2-L and X1-K terminals respectively (see Fig 8). The current value in primary CT (I'_μ) can be regulated in range: $I'_\mu=0-200A$. The investigated results as well as calculated must be listed in Table 2.

Table 2. Results of magnetizing characteristic measurements

Lp	I'_μ	$E_{(2)}$	Z_μ	Remarks
	A	V	Ω	
1				
2				

On their basis plot both voltage-current ($E_{(2)}=f(I'_\mu)$) and magnetizing impedance ($Z_\mu=f(I'_\mu)$) characteristics for the tested core balance (Ferranti) transformer.

THE DEVELOPMENT OF THE POTENTIAL AND ACADEMIC PROGRAMMES OF WROCLAW UNIVERSITY OF TECHNOLOGY

Please note that:

I'_μ - is primary magnetizing current,

$E_{(2)}$ – secondary voltage potential (at open CT terminals)

thus: magnetizing impedance Z_μ of the Ferranti CT referred to the secondary winding is:

$$Z_\mu = \frac{E_{(2)}}{I'_\mu} \mathcal{G}_F \tag{5}$$

where: \mathcal{G}_F - is turn ratio of the CT

2.2.2. Error (residual) current measurements

The measurements must be performed in the circuit as presented in Fig 10 for the cable Ferranti transformers shown in Fig 5.

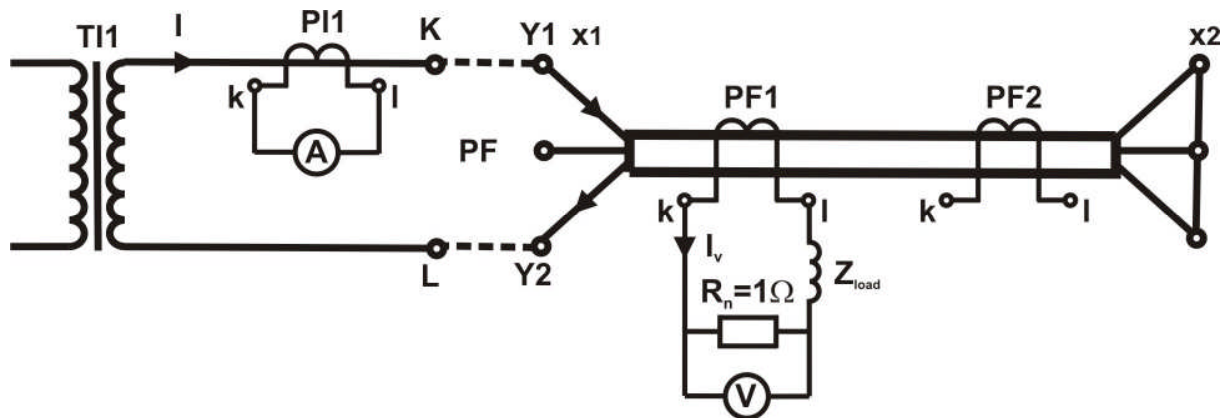

Fig. 10. Measurement of the residual (error) current (I_v) values of the core balance (Ferranti) transformer (PF1, PF2 – Ferranti CT, PL3 – measuring CT)

The residual (error) current is measured for primary current (I) value varied from 0-200A and for selected load impedance of the secondary Z_{load} (usually it is input impedance of the measuring relay applied). The result set-up in Table 3.

Table 3. The residual (error) current versus primary load (I)

Lp		1	2	3	4	Remarks
I	A	50	100	150	200	
I_v	mA					

THE DEVELOPMENT OF THE POTENTIAL AND ACADEMIC PROGRAMMES OF WROCLAW UNIVERSITY OF TECHNOLOGY

2.2.3. Measurement of the current ratio of the Ferranti CT

The circuit is presented in Fig 11 where, the supplying AT is connected to terminals X1 and X2 respectively.

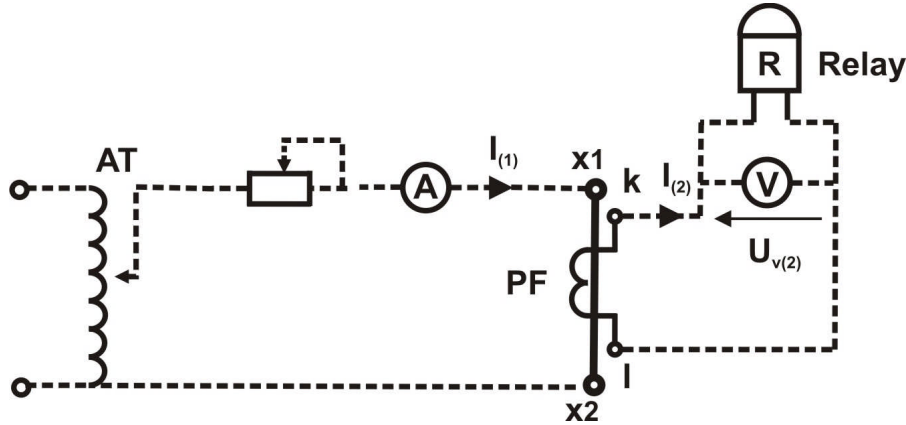

Fig. 11. Circuit for the current ratio derivation

For the secondary CT loaded with the relay, perform the measurements for all values marked on its scale. Having known impedance value of the relay the secondary current $I_{(2)}$ can be easily determined from the voltage drop across the relay terminal. Data set-up in Table 4 and calculate the current ratio \mathcal{G}_i :

$$\mathcal{G}_i = \frac{I_{(1)}}{I_{(2)}} \quad (6)$$

of the over-current protection (for selected relay) as well as theoretical (hypothetical) value of $I'_{(1)}$:

$$I'_{(1)} = \frac{I_{(1)}}{\mathcal{G}_{(i)}} \quad (7)$$

On the basis of the following formula:

$$dI_{\%} = \frac{I_{(2)} - I'_{(1)}}{I'_{(1)}} \cdot 100\% \quad (8)$$

estimate the current error $dI_{\%}$.

2.2.4. Inspection of CT windings and relay impedance

Resistance of both the secondary CT and the relay input is measured by means of the Thompson bridge. While, the over-current relay impedance Z is derived by 4-points method using sensitive electronic voltmeter.

TASK No 3 and No 4

INVESTIGATION OF SINGLE INPUT RELAYS

Concise manual

1. Introduction

System faults usually provide significant changes in the system quantities which can be tolerable or intolerable for system conditions. These changing quantities include over-current over – or under-voltage, power factor, impedance, power or current direction, frequency etc. The most common fault indicator is a sudden and generally significant increase in the current; thus over-current protection is widely used. Logic representation of an electric relay is indicated in Fig 1.

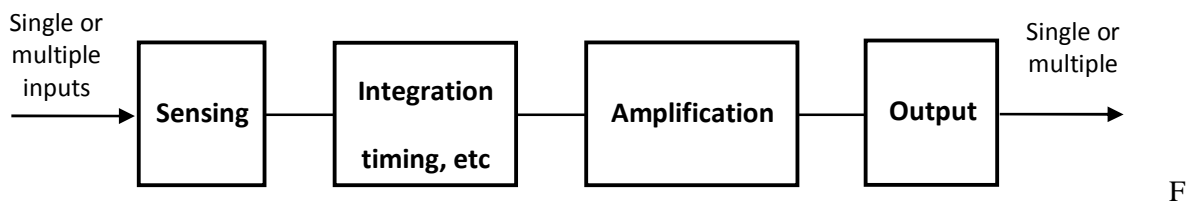

Fig. 1. Logic representation of an electric relay

Logic functions are general in nature, so that they may be combined or cancelled for particular unit.

Protective relays and associated systems (and fuses) are applied to all parts of the power system: generator, buses, transformers, transmission lines, motors, distribution lines and feeders, capacitor banks and reactors. As classified by input they are known as voltage, current, power, frequency and temperature relays. Considering performance characteristics they are known as under-, over-current, under-, over-voltage, distance, directional over-current, high-, slow speed etc. Their operating principles include electromechanical, solid-state, digital, multi-restraint and product units. In general the relay operation occurs if only measuring (primary) quantity I_{in} is over (under) threshold value (I_{op}) that is adjusted on a scale. It results in step-way change of out-put signal X_{out} from 1 to 0 or reverse from 0 to 1 (contact position) as illustrated in Fig 2. As a result performance characteristic is of hysteresis type with release coefficient k_r expressed as follows:

THE DEVELOPMENT OF THE POTENTIAL AND ACADEMIC PROGRAMMES OF WROCLAW UNIVERSITY OF TECHNOLOGY

$$k_r = \frac{I_r}{I_{op}} \tag{1}$$

where: I_{op} , I_r – operation and release current (voltage) value,

for over-current (over-voltage) $I_{op} > I_r$; $k_r < 1$,

for undercurrent (under-voltage) $I_{op} < I_r$; $k_r > 1$

The release coefficient value is required to be as close as possible to 1 what is not easy to obtain for electromechanical type relays still in widespread use and continue to be manufactured and applied.

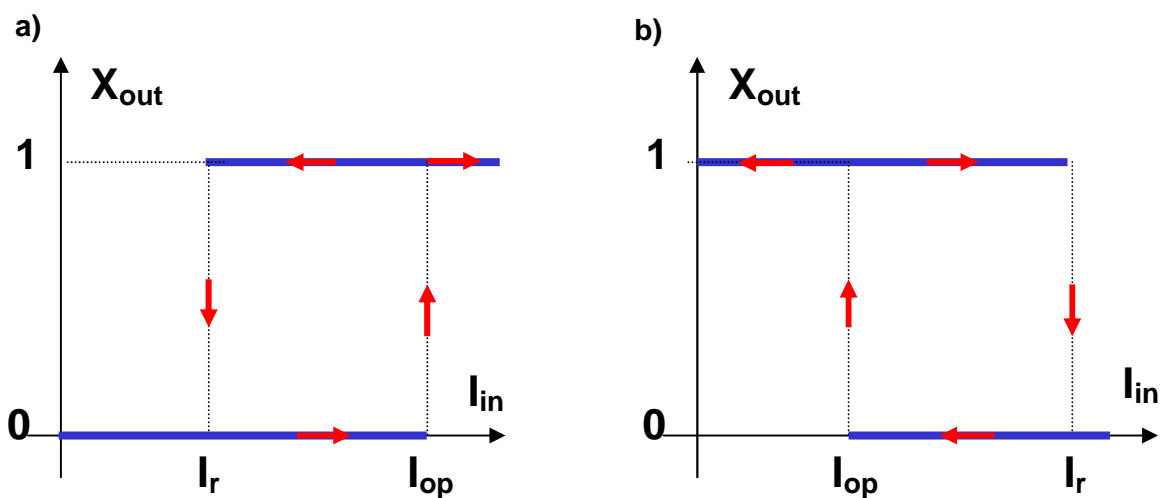

Fig. 2. Illustration of over-current (a) and undercurrent (b) relay operation (X_{out} – output signal, I_{in} – input current, I_{op} , I_r – operation and release value respectively)

2. Over-current relays and their characteristics

The design techniques used to provide relays for protection of electric power systems have progressed from electromechanical to solid state. Such types like electromechanical, solid state, hybrid and numerical are in service but currently the microprocessor designs are widely offered. The electromechanical relays provide a base for the modern units. Most of basic operational characteristics were established in mid of the last century. If about relay performance characteristics (time-current relationship) one distinguishes 3 – basic types:

- instantaneous,
- definite time,
- inverse time

what is seen in Fig 3.

THE DEVELOPMENT OF THE POTENTIAL AND ACADEMIC PROGRAMMES OF WROCLAW UNIVERSITY OF TECHNOLOGY

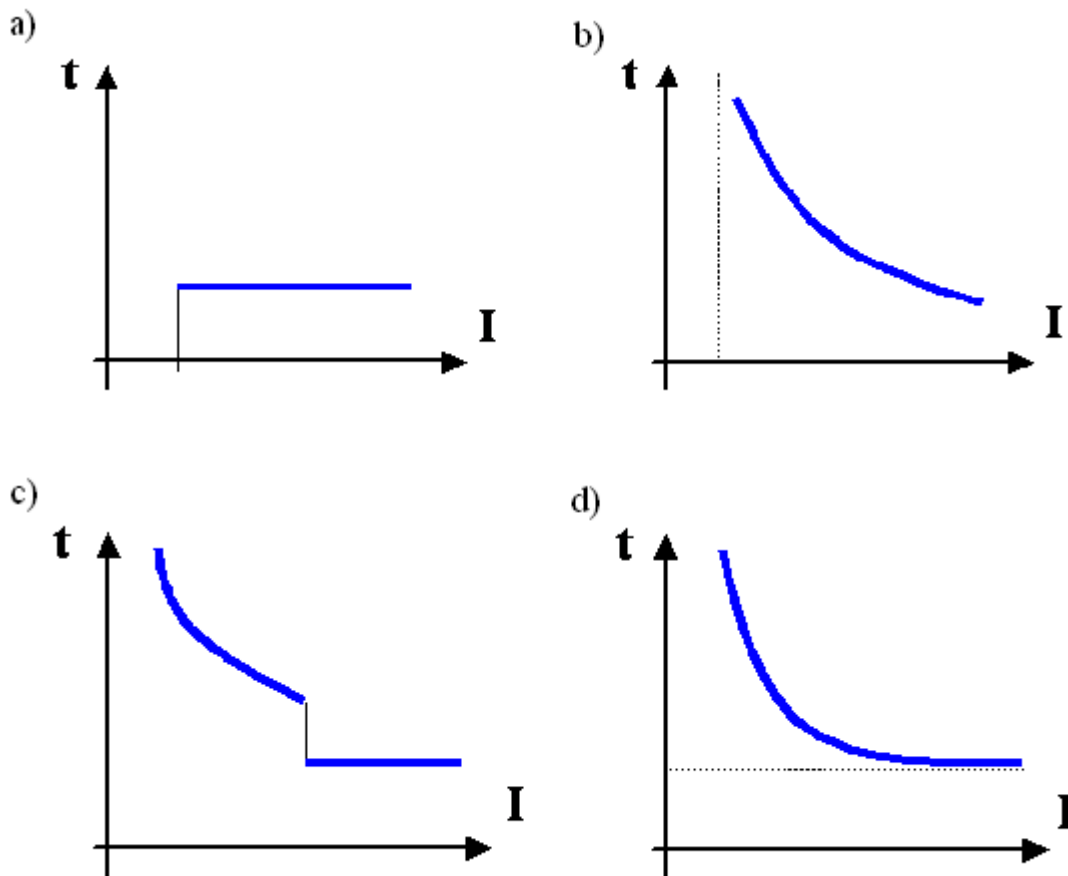

Fig. 3. Time – current characteristics of over-current relays; a) definite time, b) inverse time, c) inverse time with short-circuit pickup, d) inverse definite minimum time

For instantaneous over-current relays there are no intentional time delay. The discrimination is therefore achieved by current setting only. It relies on difference in fault levels at different locations. If about definite (independent) time relays their performance is with constant operating time regardless of current level (see Fig 3a). Coordination is achieved by time delay setting. For inverse (dependent) time relays the operating time varies inversely with fault level (see Fig 3b). In this case coordination is achieved by both current and time setting. Modern circuit breakers (moulded type) are equipped with protection of inverse time characteristics that usually compromise overload function with short-circuit element (as in Fig 3c). Inverse time characteristic however, with so called inverse definite minimum time (IDMT) function is shown in Fig 3d and in more details in Fig. 4.

THE DEVELOPMENT OF THE POTENTIAL AND ACADEMIC PROGRAMMES OF WROCLAW UNIVERSITY OF TECHNOLOGY

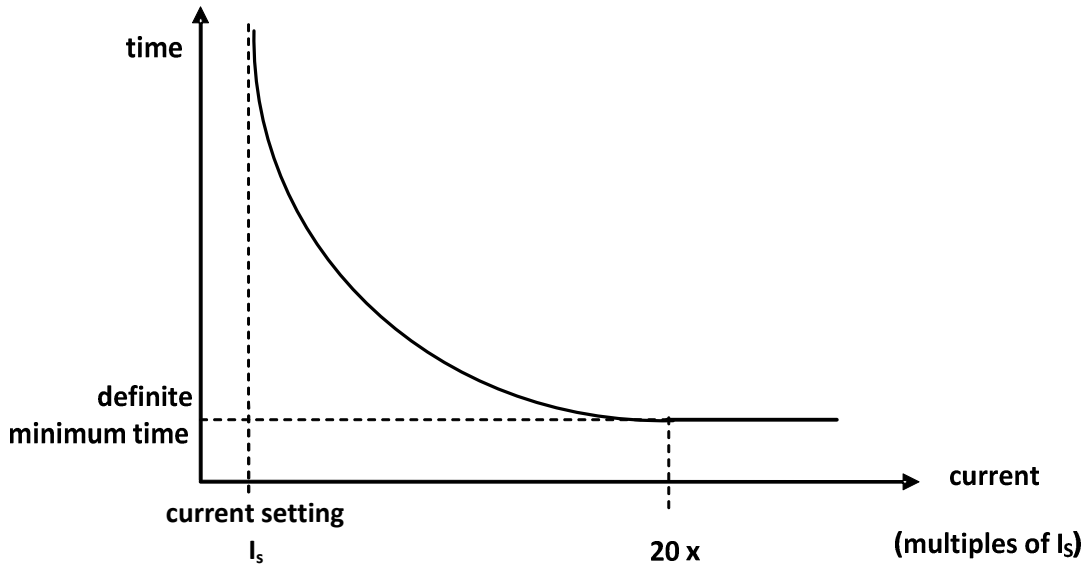

Fig. 4. Inverse definite minimum time (IDMT) characteristic

The IDMT characteristics as defined by BS 142 IEC255-4 are illustrated in Fig 5. As one can see the characteristics are definite time above 20Is.

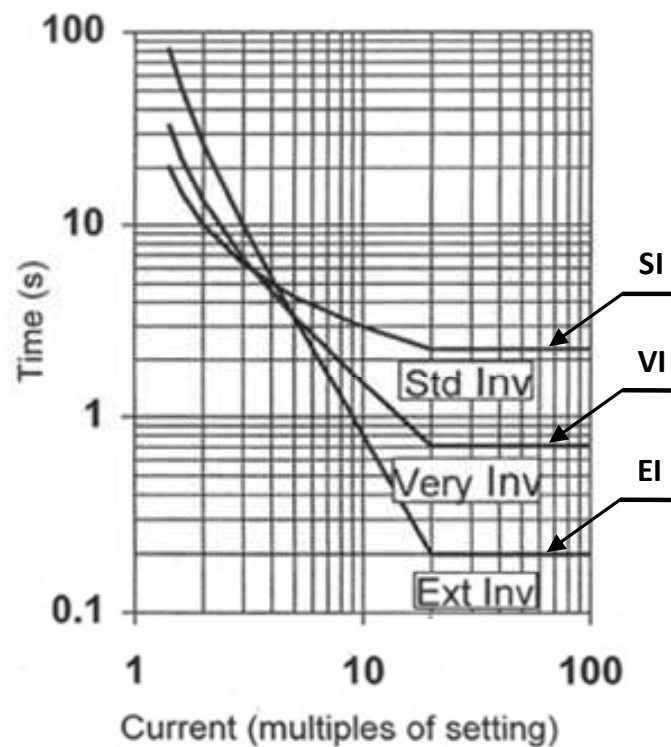

Fig. 5. IDMT characteristics defined by IEC 255-4 standard (Standard Inverse (SI) for cable circuits, Very Inverse (VI) for overhead line circuits, Extremely Inverse (EI) for transformers)

THE DEVELOPMENT OF THE POTENTIAL AND ACADEMIC PROGRAMMES OF WROCLAW UNIVERSITY OF TECHNOLOGY

2.1. Time-over-current electromechanical relay RIz

Electromechanical relay RIz type provides IDMT characteristics (Fig 4) owing to combination of time-dependent delay unit with minimum definite time element adjusted to short-circuit current value. It is induction type relay composed of a disc and an electromagnet with shorted turn as illustrated in Fig 6. Bearing of the rotation disc is free located inside gap of the electromagnet. If alternating current applied to the main coil is over about 30% of operation current value (I_{op}) magnetic flux, most of which passes the air gap and disc to the magnetic keeper (permanent magnet) and is shifted in time and phase due to shorted turn, produces rotation of the disc. However, the relay is yet not able to operate. The frame (4) is pulled off by return spring (5) and perpetual screw located on the axis is not able to interpenetrate with toothed bar. For energizing current equal and higher to the operation value (I_{op}) the frame with attached disc axis turns.

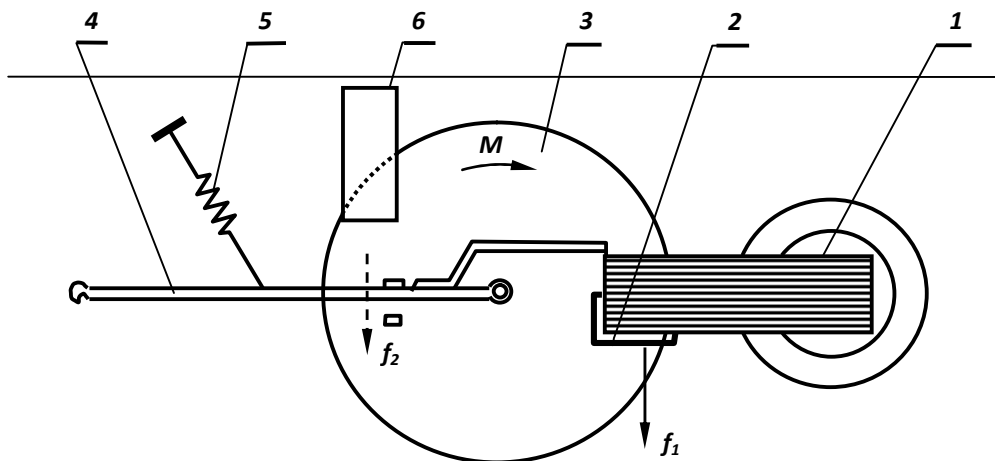

Fig. 6. Induction disc inverse- type – over-current relay RIz (1-electromagnet, 2-shorted turn, 3-disc, 4-frame, 5-spring, 6-permanent magnet)

It is under influence of combination of two forces: driving f_1 due to electromagnet and restraint f_2 produced by a permanent magnet respectively. With the increase in energizing current the disc rotation speed increases as well as the restraint force value f_2 . It results in the frames displacement what makes interpenetration of perpetual screw with the toothed bar possible. Under the perpetual screw movement the rack is lifted and provides lean of armature of instantaneous element of the electromagnet. As a result of accelerated decrease of air gap, speed of the armature of magnetic system is increased what gives effective closure of an output contact set. Time to the contact closure depends on the disc speed thus on current value in the relay coil. For the increased current value the electromagnet core becomes saturated



THE DEVELOPMENT OF THE POTENTIAL AND ACADEMIC PROGRAMMES OF WROCLAW UNIVERSITY OF TECHNOLOGY

what stabilizes delay time of the relay. As a result the operational characteristic is the IDMT type (see Fig 7). By change of initial position of the rack the performance characteristics as well as delay time can be shifted. The delay time t_n adjusted on the relay scale correspond to pickup current value. It decreases with the increase in energizing current. The operation (pickup) current can be setup in continuous way by means of adjustable pin in range of (4-10)A with resolution of 1A, or by respective taping with resolution of 0.5A within range of (2-5)A respectively. The instantaneous unit operates for the adjusted multiplication of current setting.

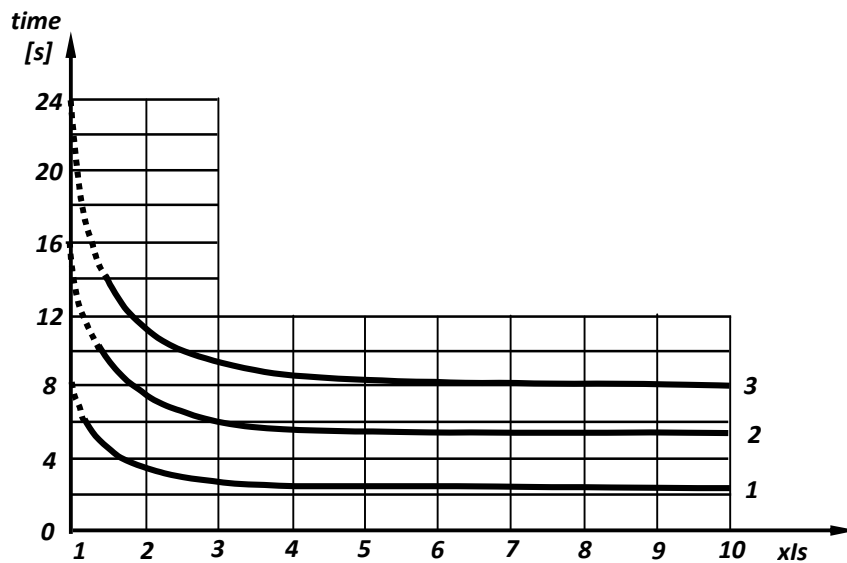

Fig. 7. Time – current characteristics of RIz-104 relay (1- for $t_n=8s$, 2 – $t_n=16s$, 3- $t_n=24s$)

2.2. Digital MiCOM P211 protection for electrical motors

MiCOM P211 protection is principally based on the importance of the motor which usually is closely related to the size. This unit (produced by AREVA Company) provides protection for 3-phase motors of low voltage basing mostly on phase current measurements.

Essentially it protects against potential hazards under:

- overload (continuous and intermittent),
- underload operation,
- abnormal conditions due to supply system disturbance (current asymmetry, open phase or phases),
- thermal damage due to both high ambient temperature and load induced (overload, jamming, high inertia, blocked ventilation),
- ground faults (optionally),

THE DEVELOPMENT OF THE POTENTIAL AND ACADEMIC PROGRAMMES OF WROCLAW UNIVERSITY OF TECHNOLOGY

- phase-to-phase faults,
- extended starting or locked rotor (failure to start or jamming).

MiCOM P211 presents compact housing and is easy for assembling and handling. Two versions are available: for assembling directly on bus DIN 35 mm and for instrument board. At the first application primary phase wires (conducting motor currents) or secondary of current transformers have to be guided through respective working holes as indicated in Fig 8. Under location at the instrument board the current conductors are screwed down to relay input current terminals however, rated current in this case is not allowed to be over 6 A (if external CTs are not employed). When, rated currents of motor being protected are much below setting range of the protection additional turns must be used. However, the setting has to be verified by number of wound turns (multiplication). MiCOM P211 provides many benefits such as higher accuracy, reduced space lower, equipment and installation costs as well as wider application (for different motor types operating under various supply conditions). Setting event recording, remote sensing (optional communication port RS485), self monitoring and checking is included. As a result for example ground fault current, thermal state of the motor as well as parameters of last start-up can be displayed and controlled.

For overload protection the microprocessor MiCOM P211 relay uses thermal replica (mathematical thermal model) of the motor. This model is derived from the input currents, voltage, manufacturer's motor data and resistance temperature detectors (RTD) embedded in the motor windings. Therefore, influence of higher harmonics (10Hz – 1 kHz) on the motor heating can be depicted precisely.

Basic parameter that has to be loaded for the mathematical thermal model derivation is time t_{6I_s} equivalent to heating time constant T_{Heat} that represents allowed time of overloading under 6 multiples of setting I_s (rated) current (so called "tripping" class). For different preheating state respective time – current characteristics of MiCOM P211 overload protection are presented, for example, in Fig 9. Overload unit operates at 100% thermal state of the electrical motor. Cooling characteristics are also calculated however use different algorithm for the same load current value equal to $6I_s$. Simulated by MiCOM P211 thermal state of protected motor during different operation based on measured phase currents can be compared for example from Fig 10. The overload unit can be reset both manually and automatically for cold machine, depends on requirements, to allow for motor restarting.

THE DEVELOPMENT OF THE POTENTIAL AND ACADEMIC PROGRAMMES OF WROCLAW UNIVERSITY OF TECHNOLOGY

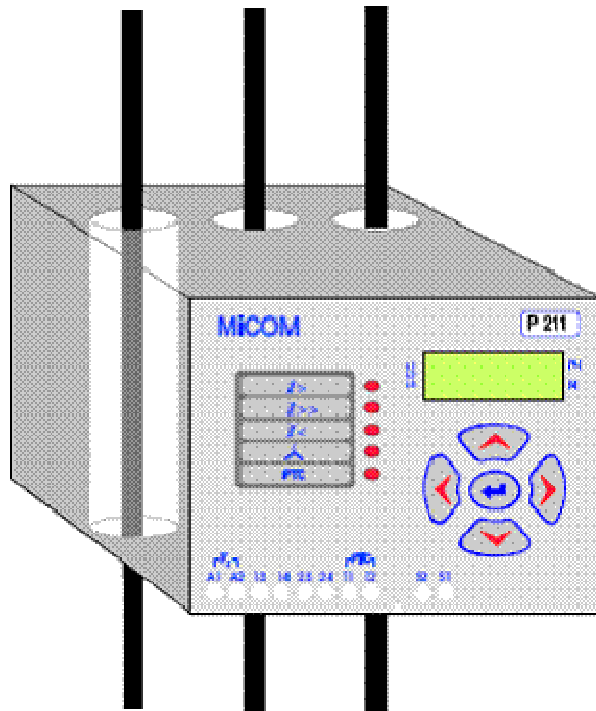

Fig. 8. General view of MiCOM P211 protection

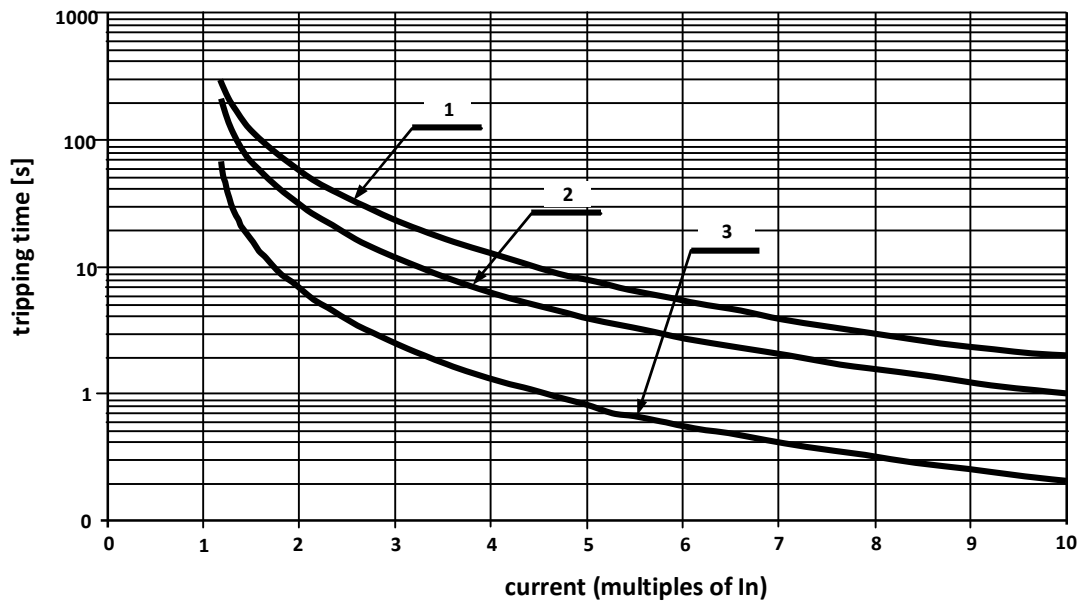

Fig. 9. Selected time – current characteristics for various initial thermal state Θ

(1 - $\Theta=0$; 2 - $\Theta=0.5$; 3 - $\Theta=0.9$; I_n – rated current)

THE DEVELOPMENT OF THE POTENTIAL AND ACADEMIC PROGRAMMES OF WROCLAW UNIVERSITY OF TECHNOLOGY

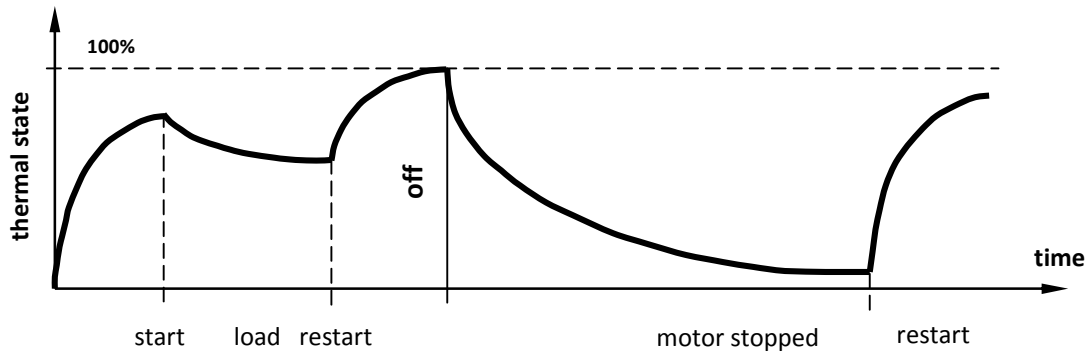

Fig. 10. Simulated thermal state of a motor

To adjust the thermal model properly to a motor being protected one has to load:

- basic (setting) current (rms) value (rated) of a motor - I_s ,
- specified maximum time of continuous current flow $I=6I_s$ - t_{6I_s}

Setting current I_s (in current inputs) is equal to rated value (I_n) of the motor for one turn as in Fig 8. (If 2-turns are used the current setting on a scale should be modified at 2-times I_s respectively).

Specified maximum time t_{6I_s} of loading with $6I_s$ current value is selected for “cold” thermal state of a motor. Thus, basing on t_{6I_s} time respective time constant values are calculated as follows:

$$T_{Heat} = 32 \times t_{6I_s} \quad \text{- heating time constant,}$$

$$T_{cool} = 4 \times T_{Heat} \quad \text{- cooling time constant.}$$

As a result thermal state of the motor, represented by temperature value (Θ), is derived from formula:

$$\Theta_i = \left[\frac{I_{mean,i}}{1.1 \cdot I_s} \right]^2 \cdot \left[1 - \exp\left(-\frac{0.128}{T_{Heat}} \right) \right] + \Theta_{i-1} \cdot \exp\left(-\frac{0.128}{T_{Heat}} \right) \quad (2)$$

where:

Θ_i – instantaneous temperature value (for i-step),

Θ_{i-1} – temperature calculated for previous (i-1) step,

$I_{mean} = (I_{L1} + I_{L2} + I_{L3}) / 3$ - mean value,

I_{L1}, I_{L2}, I_{L3} – rms current load in L1, L2, L3 phase respectively,

$I_{mean,i}$ – mean value for i-step.

Calculations are carried out at each 0.128 s step.

THE DEVELOPMENT OF THE POTENTIAL AND ACADEMIC PROGRAMMES OF WROCLAW UNIVERSITY OF TECHNOLOGY

For a case if $I_{mean} \leq 0.1 \times I_s$ (cooling state) the thermal state of the motor is obtained as follows:

$$\Theta_i = \Theta_{i-1} \cdot \exp\left(-\frac{0.128}{T_{Heat}}\right) \quad (3)$$

The MiCOM P211 operates if heating corresponds to 100% thermal state.

For the electrical motor previously loaded and when restart is performed for initially heated state corresponding to Θ_s temperature, time to operation (to switch off) is equal:

$$t = T_{Heat} \cdot \log_e \left[\frac{\left(\frac{I_{Mean}}{1.1 \cdot I_s}\right)^2 - \Theta_s}{\left(\frac{I_{Mean}}{1.1 \cdot I_s}\right)^2 - 1} \right] \quad (4)$$

where: Θ_s – temperature at restart ($t=0$).

However, for start-up the cold machine this time to operation is calculated from formula modified as follows:

$$t = T_{Heat} \cdot \log_e \left[\frac{\left(\frac{I_{Mean}}{1.1 \cdot I_s}\right)^2}{\left(\frac{I_{Mean}}{1.1 \cdot I_s}\right)^2 - 1} \right] \quad (5)$$

2.3. Investigations procedures

Purpose of testing is acquaint student with structure, principle of operation and test as well a measurement procedures of single input relays. TASK No 3 concerns testing of inverse time (dependent) over-current relays while, TASK No 4 – instantaneous and definite time (independent) both over-current, over-voltage and/or under-voltage relays respectively.

THE DEVELOPMENT OF THE POTENTIAL AND ACADEMIC PROGRAMMES OF WROCLAW UNIVERSITY OF TECHNOLOGY

TASK No 3 – investigation of inverse time over current relays

Two types of relays were selected for testing: typical induction disk inverse – type – over-current relay (RIZ) (still widely used in many applications throughout the power system) and modern the microprocessor designs over-current inverse time dependent relay MiCOM P211.

1. Functional tests: operate and release current value

The operate (I_{op}) and release (I_r) current value shall be measured in circuit as indicated in Fig 11. It has to be done for all setting values (I_{opn} , I_{rn}) marked on the relay scale. Arithmetic average of five following measurements I_{opmean} , I_{rmean} is taken as the operate (release) value.

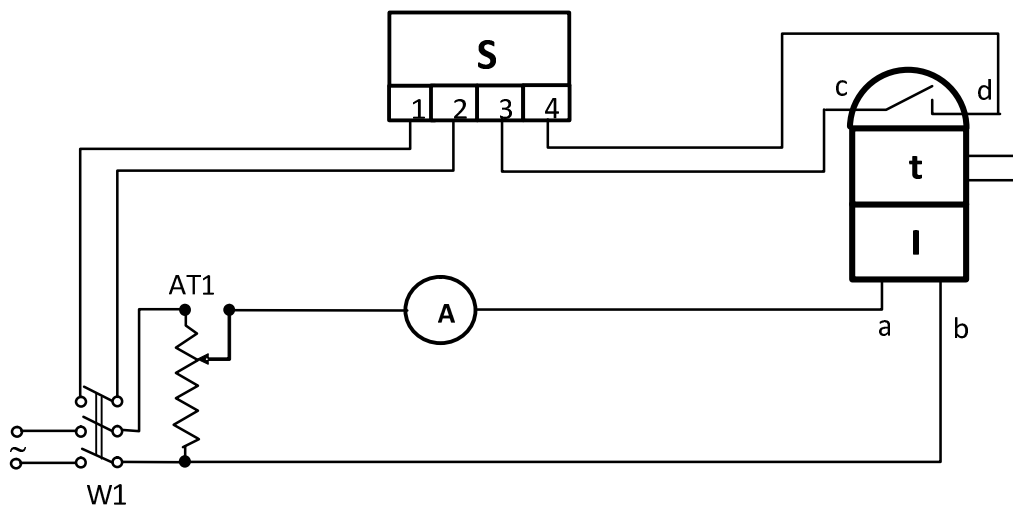

Fig 11. Typical circuit for the measurement of operational characteristics

For the electromechanical over-current RIZ relay as the operate parameter (I_{op}) is taken minimum current value, that flows in relay energizing coil, under which perpetual screw interpenetrates with toothed bar. While, the release (I_r) is the highest value that results in return of movable measuring elements to initial position. Since, the release value (I_r) shall be measured before the relay starts to operate therefore, time setting should be selected as high as possible under this test.

THE DEVELOPMENT OF THE POTENTIAL AND ACADEMIC PROGRAMMES OF WROCLAW UNIVERSITY OF TECHNOLOGY

On the basis of investigated results both release coefficient k_r ($k_r = \frac{I_r}{I_{op}}$), scale error ΔI ($\Delta I_{op} = \frac{I_{op} - I_{opn}}{I_{opn}} \cdot 100\%$) and spread of averages RI ($RI = \frac{I_{op} - I_{opmean}}{I_{opmean}} \cdot 100\%$) is calculated.

According to specified requirements the release coefficient should not be lower than 0.85, scale error – not over 5% and spread of averages – not exceed 5% respectively. All measured and calculated quantities like: operation current value adjusted on the scale (I_{opn}), measured operation (I_{op}) and release (I_r) current, arithmetic average operation (I_{opmean}) and release (I_{rmin}), release coefficient (k_r), spread of averages (RI) as well as scale error (ΔI) should be listed in respective table.

2. Inverse time (dependent) characteristics

The test shall be conducted in the circuit as in Fig 11. By means of autotransformer (AT) fix current value and during switching off and – on (W – switch) measure delay time of the relay. Repeat it 5 – times for the same conditions of testing. Next, at the same setting on a scale, select another current value to derive successive point of operational characteristic. The measurements should be performed at the lowest current setting (minimum operation I_{op} value) changing energizing current flowing in the relay coil in the range $(1 - 5)I_{opn}$. Operation time shall be estimated from 5 following testing results (arithmetic average). (Time-current characteristics if RIz-104 relay are indicated for comparison in Fig 7). For each current value find spread of averages for operation time on the basis of 5 successive measurements. It must be within the accepted limits.

Test procedure for MiCOM P211 is similar.

TASK No 4 – investigation of instantaneous and definite time relays

relays

Investigations shall be carried out using the same circuit as for inverse time (dependent) relays (see Fig 11). For testing will be selected both over-current as well as over-and-under-voltage single input units delivered by responsible teaching staff member.

1. Operate and release values

Test and measurement procedure for instantaneous and definite time over-current relays is the same as for time dependent ones (operate and release current as well as time values). However, over- and/or -under-voltage relays shall be monitored in circuit as presented in Fig 12 and 13.

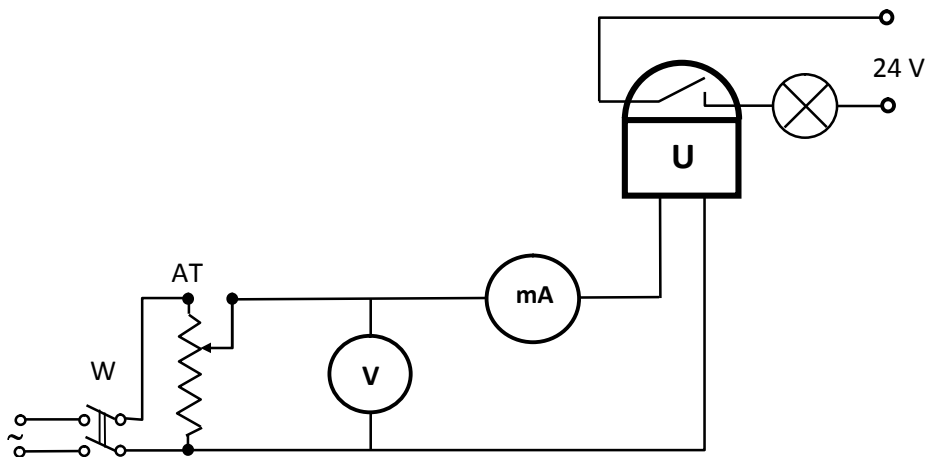

Fig 12. Typical circuit for testing instantaneous over- and/or –under-voltage relays

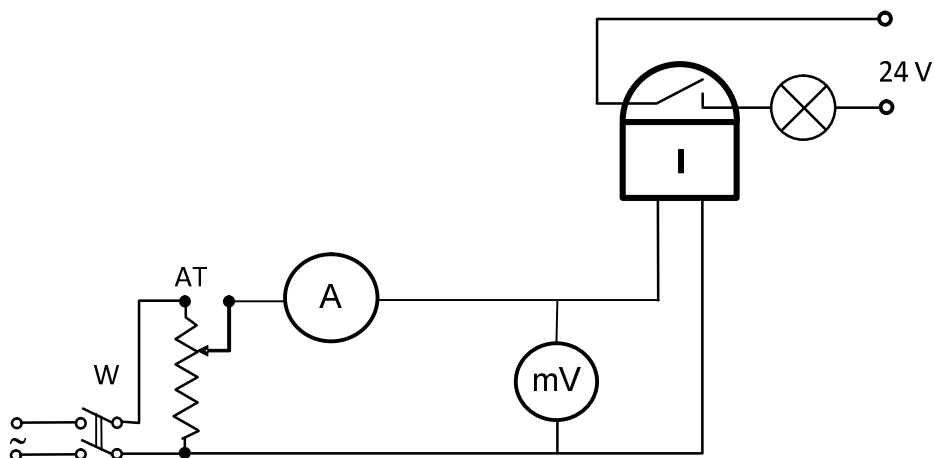

Fig 13. Typical circuit for testing instantaneous overcurrent relays

TASK No 5

INVESTIGATION OF DIRECTIONAL RELAYS

Concise specification (manual)

1. Applicability of directional relays

Directional relays have been developed to determine direction of short circuit power flow (current flow). They are used in different protection systems to meet requirements if about selectivity; mostly in overcurrent protections of ring type distribution systems and/or double supplied system as well as in distant protections. As independent measuring units they are widely used in ground fault protections of MV distribution networks.

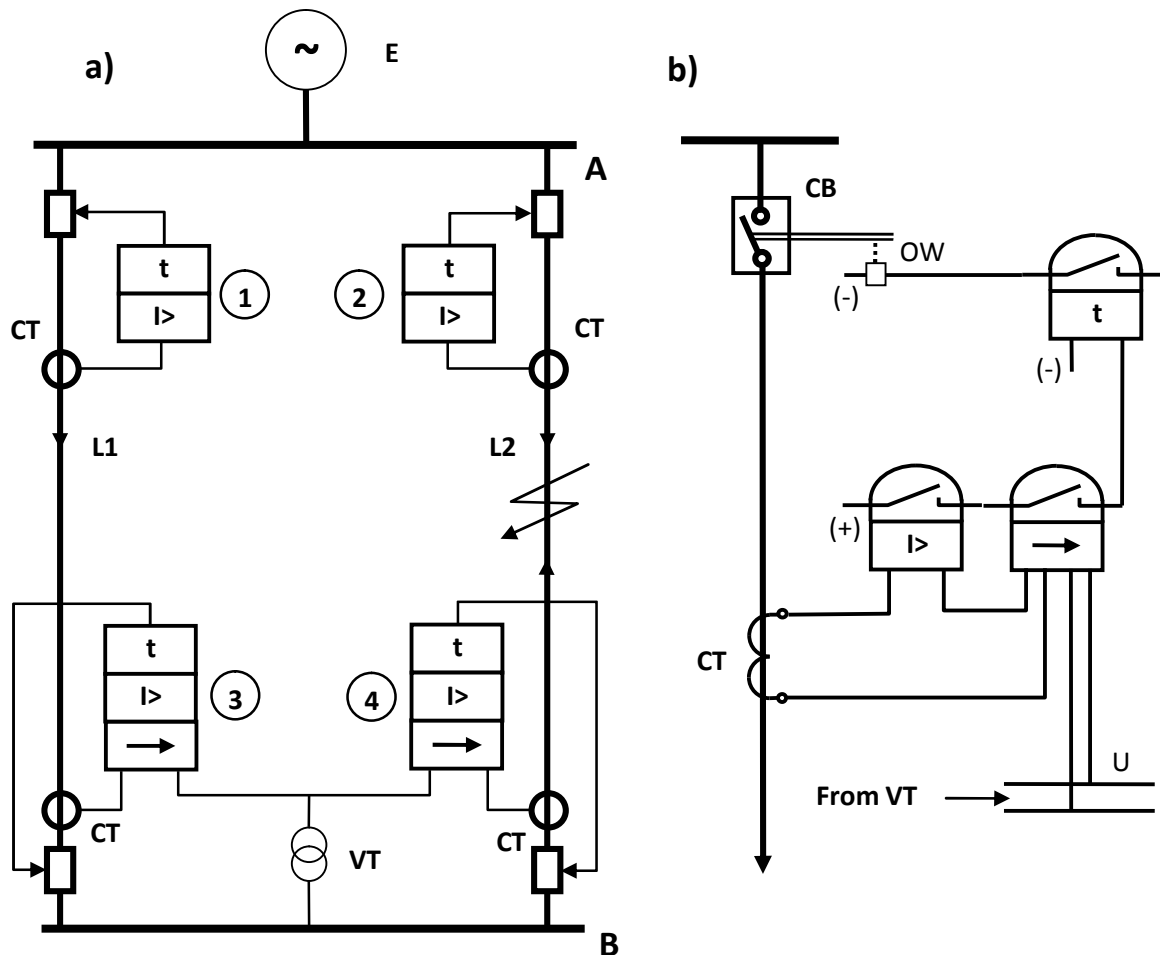

Fig. 1. Example of application of directional relays; a) ring type distribution system with directional overcurrent protections, b) schematic diagram of time delayed overcurrent protection

Example of application of directional relays in time delayed overcurrent protection for simple closed ring system is illustrated in Fig. 1. Two cables $L1$ and $L2$ provide alternative path to MV substation B . To meet requirements if about selective operation of time delayed current protections it

THE DEVELOPMENT OF THE POTENTIAL AND ACADEMIC PROGRAMMES OF WROCLAW UNIVERSITY OF TECHNOLOGY

is needed to employ directional relays to detect short circuit power flow depending on location single cable fault. In this case both lines at B substation require directional relays to interlock the operation if the fault current flows in direction to busbars of the B substation (down stream). The relays at both substations have different time setting to achieve coordination. These at B substation (t_B) must be smaller than at A substation (t_A) by discrimination margin Δt usually equal to about 0.4 s – 0.5 s. Therefore, in a case of a fault location in L2 feeder (see Fig 1) all current measuring elements will be activated however discrimination is achieved only by operation with t_B setting of the time delayed directional overcurrent protection number 4 (fault power flows outwards the B substation – upstream) while directional element of protection number 3 is at that time blocked. After B-substation feeder breaker at cable L2 is operated, current in the cable L1 is reduced to its normal load value and overcurrent elements of two respective protections (1 and 3) return to off-state as a result. However, still time delayed overcurrent protection (no 2) is energized and after t_A time setting it provides the fault clearance by opening A bus – section breaker.

Current setting for all protections applied must be performed above maximum value of normal load current and must allow for any planned overload as well as for resetting of relay when fault cleared in the same way as radial system. Also time grading is achieved according to the same principles as for time delayed overcurrent protections of radial lines with respective discrimination margin (Δt) i.e. $t_i = t_{i-1} + \Delta t$.

Directional time delayed overcurrent protection can be realized as 2 phases or 3 phases solution as indicated in Fig 1b. The 2 phases structure is usually employed in distribution networks with unearthed neutral point.

2. Principle of operation and basic characteristics of directional relays

Directional relays require a reference signal to determine direction of current flow (short circuit power flow). They can use system voltage as the reference. If reference signal is lost relay cannot make directional decision. Therefore, arises a question which voltage should be used to polarize directional relay?

Best performance for all fault conditions is obtained using following relationship between current being measured and voltage:

If: phase A relay : I_a current, U_{bc} as polarizing voltage,
phase B relay : I_b current, U_{ca} as polarizing voltage,
phase C relay : I_c current, U_{ab} as polarizing voltage.

It is referred to as 90° connection what is illustrated in Fig. 2.



THE DEVELOPMENT OF THE POTENTIAL AND ACADEMIC PROGRAMMES OF WROCLAW UNIVERSITY OF TECHNOLOGY

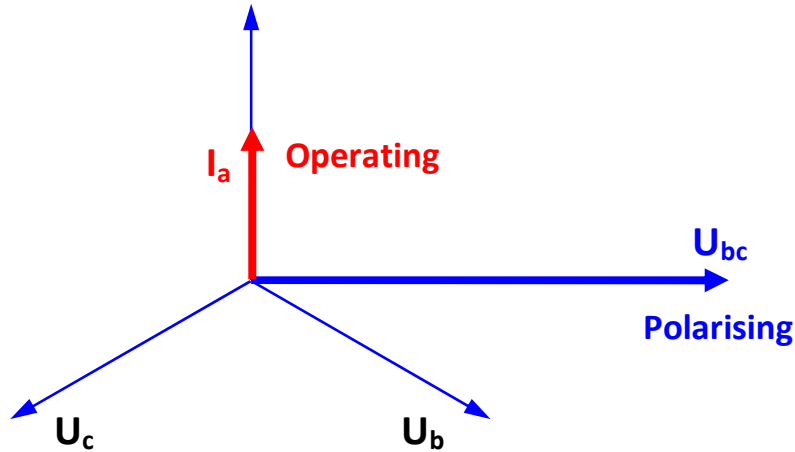

Fig. 2. Illustration of choice of voltage reference

It is obvious that directional relay is not able to operate correctly for too small values of current and voltage being delivered. Therefore, its recommended setting must be based on detailed analysis and practical experience. Its performance should be tested under real conditions of operation. Both relay characteristic angle (RCA) as well as relay connection angle must be known.

Relay Connection Angle is an angle by which the applied current is displaced from the applied voltage at unity power factor. It can be for example 90° connection as shown in Fig. 3.



Fig. 3. Relay connection angle equal 90°

Next important physical quantity that has to be specified is **Relay Characteristic Angle (RCA) Ψ** . It is the angle by which the applied current must be displaced from the applied voltage (anticlockwise – to lead) to produce the maximum operating signal.

The RCA is also referred as the **Maximum Power Angle (P_{opm})** or **Maximum Torque Angle (MTA)**. It determines the directional relay operate zone.

Typical settings of Ψ : 45° lead, 30° lead

Therefore value of active power P delivered:

$$P = kUI \cos(\varphi - \psi) \geq P_{op} \tag{1}$$

must be sufficient to operate the directional relay (P_{op}),



THE DEVELOPMENT OF THE POTENTIAL AND ACADEMIC PROGRAMMES OF WROCLAW UNIVERSITY OF TECHNOLOGY

where: U – applied voltage at voltage input terminals of the relay,
 I – applied current at current input terminals of the relay,
 φ - angular displacement between voltage and current of protection area (object),
 k – multiplication factor,
 P_{op} – operating power of the relay,
 ψ - relay characteristic angle.

Recommended settings are based on detailed analysis and practical experience as it is concluded from equation (1) the RCA value (ψ) should be selected to be equal to angular displacement ($\psi=\varphi$) to deliver maximum operation power (P_{opm}) under short circuit conditions.

Example of directional relay characteristic for 90° connection and 45° lead RCA is illustrated in Fig 4.

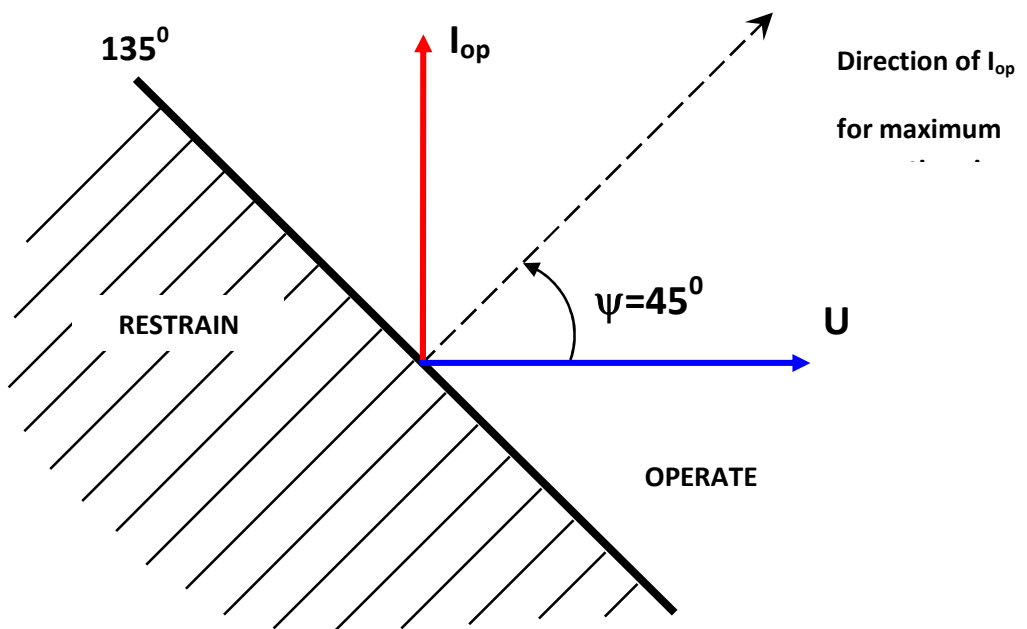
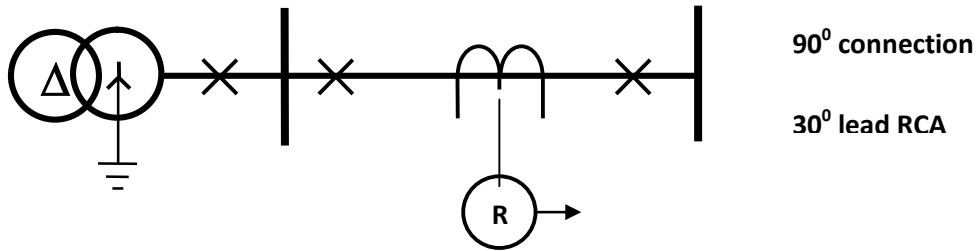

Fig 4. Example of directional relay characteristic

Recommended settings for detailed are indicated in Fig 5.

THE DEVELOPMENT OF THE POTENTIAL AND ACADEMIC PROGRAMMES OF WROCLAW UNIVERSITY OF TECHNOLOGY

a) Plane feeder



b) Transformer feeder

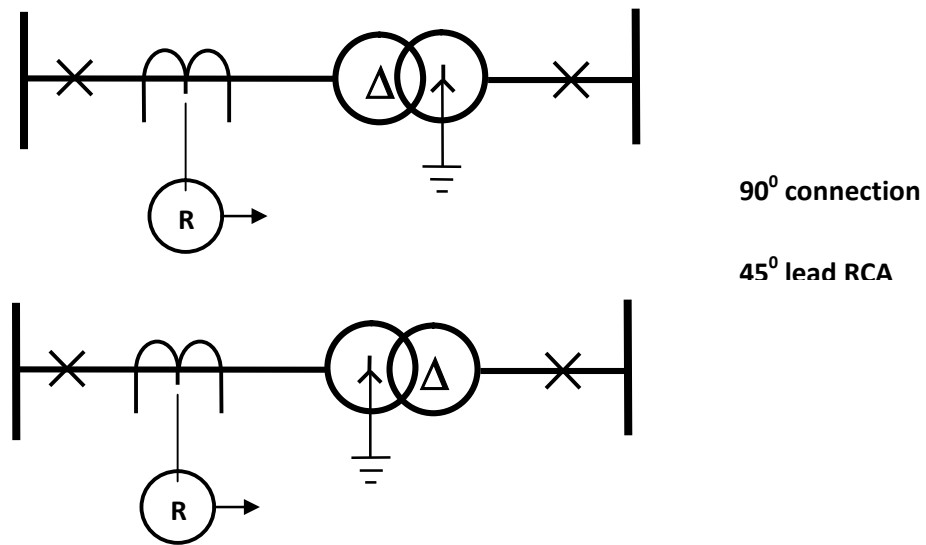

Fig. 5. Setting of directional relays for selected application

Operation conditions of the directional relays are usually analyzed on the basis of their operating characteristics. There are three basic characteristic specified as follows.

1. Operating voltage U_{op} versus current I value $U_{op}=f(I)$ for $\varphi=\psi=const$

From eq. (1), when assume that $\varphi=\psi$, it gives:

$$U_{op} = \frac{P_{op}}{I} \tag{2}$$

what is illustrated in Fig 6.



THE DEVELOPMENT OF THE POTENTIAL AND ACADEMIC PROGRAMMES OF WROCLAW UNIVERSITY OF TECHNOLOGY

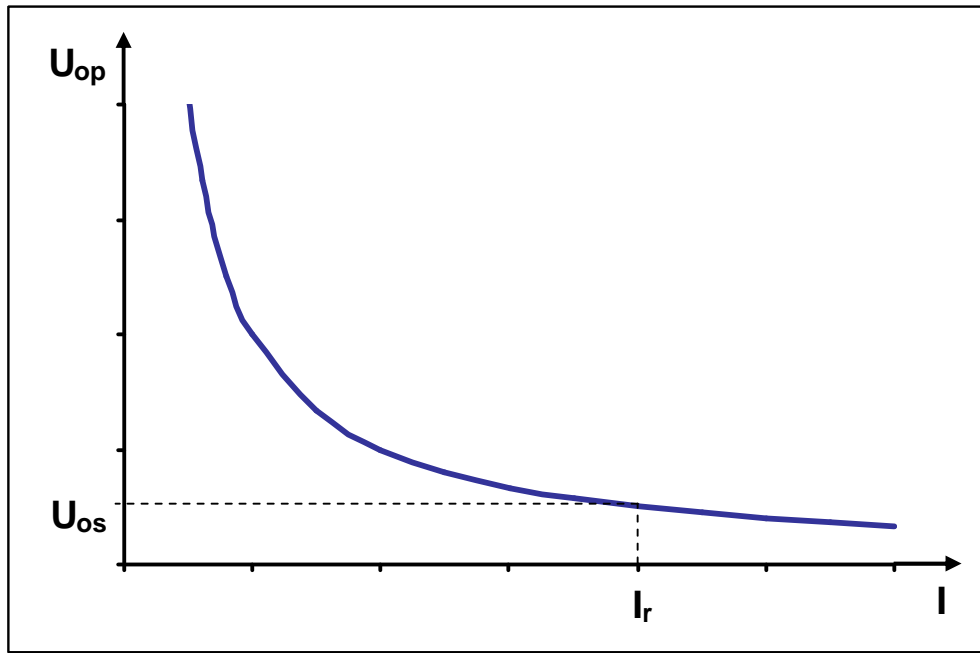

Fig. 6. Operating characteristic $U_{op}=f(I)$ of directional relay

Operational voltage value U_{os} for rated current (I_r) of the relay is defined as directional sensitivity of it. Usually it is expressed as relative value referred to rated voltage U_r of the relay.

$$U_{os} = \frac{U_{os}}{U_r} \cdot 100 \quad (2)$$

Since, usually $U_r=100V$ therefore, measured U_{os} is value (in volts) expressed at once percentage of directional sensitivity of the relay.

Note, that for the directional electromechanical relays still used in practice, characteristic $U_{op}=f(I)$ can differ significantly from this given in Fig 6 (for constant P_{op} value). It results from application of nonlinear elements (e.g. bulbs), in voltage circuit to increase the relay sensitivity (decrease of P_{op} value) in a case of short circuits close by protection. Besides, due to saturation of magnetic circuit of the electromechanical relay U_{op} value decreases significantly with current only up to its double rated value $2I_r$.

2. Angular characteristic $U_{op}=f(\varphi)$ for $I=I_r=const$

$U_{op}=f(\varphi)$ characteristic is of great importance in a case of multi short circuits where voltage value of the short circuit loop depends significantly on distance from the fault with respect to the relay location. However, for directional earth fault protections using either residual and neutral current usually dependence of operating current I_{op} versus φ value ($I_{op}=f(\varphi)$ for constant voltage value $U=U_r=const$) is measured. Because, for solidly earthed systems zero sequence voltage (residual value



THE DEVELOPMENT OF THE POTENTIAL AND ACADEMIC PROGRAMMES OF WROCLAW UNIVERSITY OF TECHNOLOGY

U_o) is relatively high and slightly depends on fault location in network. This characteristic can be obtained directly from eq. (1):

$$U_{op} = \frac{P_{op} / I_r}{\cos(\varphi - \psi)} \tag{4}$$

what is illustrated in Fig 7.

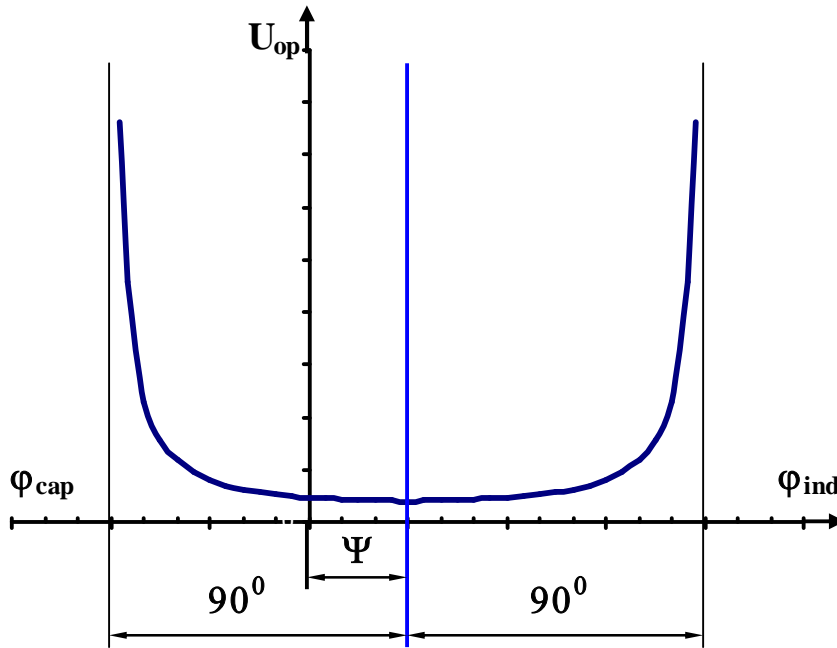

Fig. 7. Angular characteristic of directional relay

As one can see from Fig 7, the angular characteristic is situated between two asymptotes distant by angle equal to $\pi/2$ from Relay Characteristic Angle (ψ). It is usually measured by means of independent phase shifter as a voltage source with regulated both magnitude and phase. The ψ value is thus determined by symmetrical of the characteristic, perpendicular to x-axis respectively. One has to take into account that curve tracing can vary from this illustrated in Fig 7 on account of nonlinear elements used in voltage and/or current measuring circuits of the relay.

3. Directional relay characteristic on impedance plane (Z) for I=I_r

Characteristic drawn on impedance plane $\underline{Z} = \frac{U}{I} = R + jX$ discriminates operate and restrain areas where \underline{Z} is impedance evaluated from input terminals of a relay (in front of relay location). It results directly from eq. (1) if divided by I^2 what gives:

$$Z \cos(\varphi - \psi) = a \tag{5}$$

where: $Z=U/I$ – impedance modulus,

THE DEVELOPMENT OF THE POTENTIAL AND ACADEMIC PROGRAMMES OF WROCLAW UNIVERSITY OF TECHNOLOGY

φ - argument of \underline{Z} ,
 $a = P_{op}/I^2$.

a - determines dead zone of the directional relay where polarizing voltage does not exceed minimum level of power required to operate correctly what is seen in Fig 8.

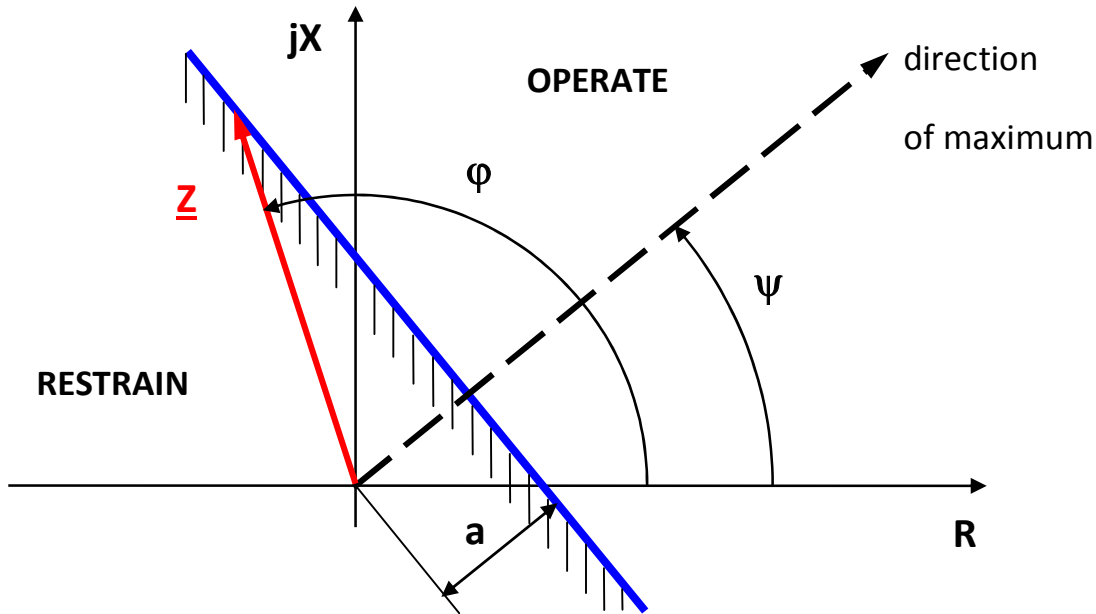

Fig. 8 Directional relay characteristic on impedance plane

Explanation of the dead zone can be performed on the basis of Fig 9. The directional relay installed in substation A controls direction of the flow of short circuit power. It is provided by short circuit current I and residual voltage U (voltage drop of short circuit) that depends on the ratio of source impedance Z_S and line impedance Z_L as follows:

$$\underline{U} = \underline{I} \cdot \underline{Z}_L = \frac{\underline{E}}{\underline{Z}_S + \underline{Z}_L} \cdot \underline{Z}_L \tag{6}$$

If short circuit point draws to A substation, contribution of line impedance \underline{Z}_L is decreased and residual voltage \underline{U} lessens significantly. As a result, at same distance from substation A the residual voltage is not sufficient to polarize directional relay (delivered power is less than minimum operating value P_{op}) and will neither operate nor restrain.



THE DEVELOPMENT OF THE POTENTIAL AND ACADEMIC PROGRAMMES OF WROCLAW UNIVERSITY OF TECHNOLOGY

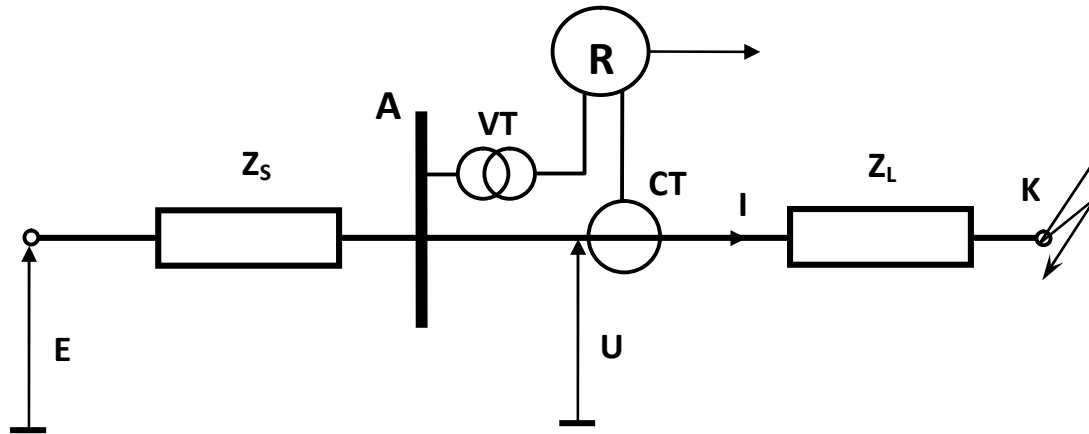

Fig 9. Explanation of operation conditions of directional relay under short circuit in feeder; A – source substation, Z_s – source impedance (behind relay location), Z_L – line impedance (in front of relay location), VT, CT – voltage and current transformers respectively, I, U – short circuit current and voltage (residual)

3. Test and measurement procedures

3.1. Evaluation of relay characteristic angle (RCA)

Schematic diagram for evaluation of RCA value is shown in Fig 10.

The relay current circuit is energized by means of autotransformer AT2 connected directly to low voltage source while this of voltage – from AT1 autotransformer supplied via phase shifter respectively. Wattmeter is used only to determine zero displacement angle between current and voltage. At the output terminals one can use either light bulb indicator or any auxiliary relay.

First zero displacement angle (for the phase shifter handle location) must be determined. Therefore, rated current value of the relay is setted while, voltage is increased up to about 50 V rms. Next, by variation of the phase shifter handle location, indicating needle of the wattmeter has to be reduced to zero position. It means that the applied current is displaced from the applied voltage by 90° . Thus, moving pointer of the phase shifter must be fixed to indicate 90° and locked mechanically. (One has to check if for 0° adjustment of the phase shifter, the wattmeter indicates maximum value).

THE DEVELOPMENT OF THE POTENTIAL AND ACADEMIC PROGRAMMES OF WROCLAW UNIVERSITY OF TECHNOLOGY

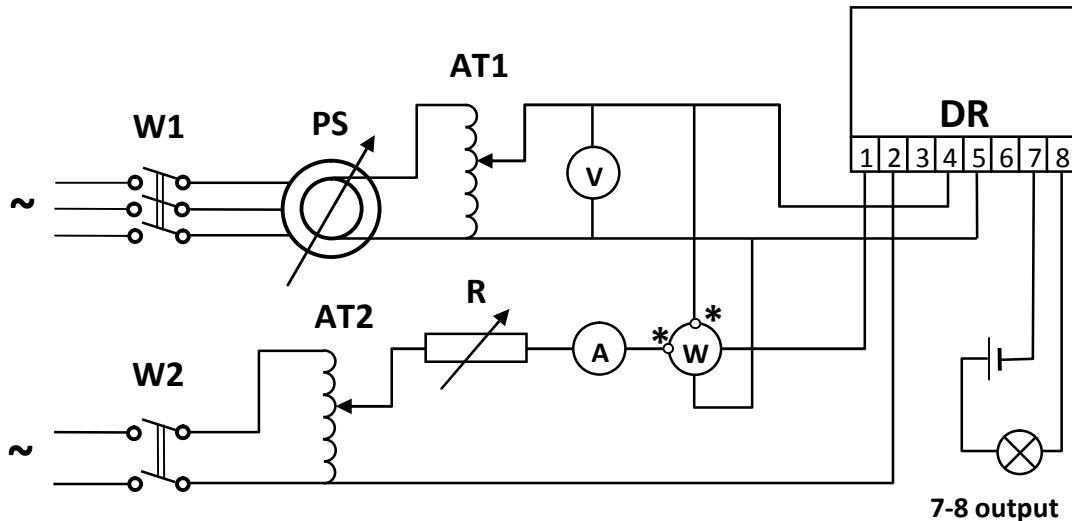

Fig. 10. Typical circuit for the measurement of RCA; PS – phase shifter, AT1, AT2 – autotransformers, DR – directional relay.

When the phase shifter is setted to 90^0 (wattmeter indicates zero) one must shunt momentarily current input terminals of the wattmeter while observing needle movement. If it is to the left (anticlockwise) its indicates inductive loading (current lag) on the contrary, when swing of pointer is opposite (to the right) – load is capacitive and current lead voltage vector respectively.

During the test current must be fixed constant and equal to rated value of the relay. Next for zero displacement ($\varphi=0^0$) voltage is slowly increased up to the relay operation. Operating power value is then recorded for any other displacement angle being changed with resolution from 5^0 up 20^0 . The resolution of course should be highest at areas close to asymptotes. (Attention: to avoid overheating of voltage circuit of the electromagnetic relay, the measurements have to be stopped if voltage value exceeds 50 V).

Results of measurements must be listed in Table 1 and used for drawing a curve $U_{opa}=f(\varphi)$, where U_{opa} is average value of operating voltage. On the basis of the obtained angular characteristic the relay characteristic angle ψ can be easily evaluated.

Table 1. Results of measurements of angular characteristic $U_{op}=f(\varphi)$ of directional relay

Directional relay: type....., No.....				
$I_r = \dots\dots\dots$, $U_r = \dots\dots\dots$, $\psi = \dots\dots\dots$, $\psi_{setted} = \dots\dots\dots$				
Current value in current circuit: $I = \dots\dots\dots A = const$				
No	φ	U_{op}	U_{opa}	notes
1				

THE DEVELOPMENT OF THE POTENTIAL AND ACADEMIC PROGRAMMES OF WROCLAW UNIVERSITY OF TECHNOLOGY

3.2. Evaluation of characteristic $U_{op}=f(I)$ and $S_{op}=f(I)$

As results from eq. (2) the $U_{op}=f(I)$ characteristic should be hyperbolic in shape however, for electromagnetic directional relay due to saturation of magnetic circuit applied it is deformed as illustrated in Fig 11 (operating power S_{op} of the relay increases). The measurements are performed in circuit as in Fig 10 however, for constant value of resistor R used in current circuit.

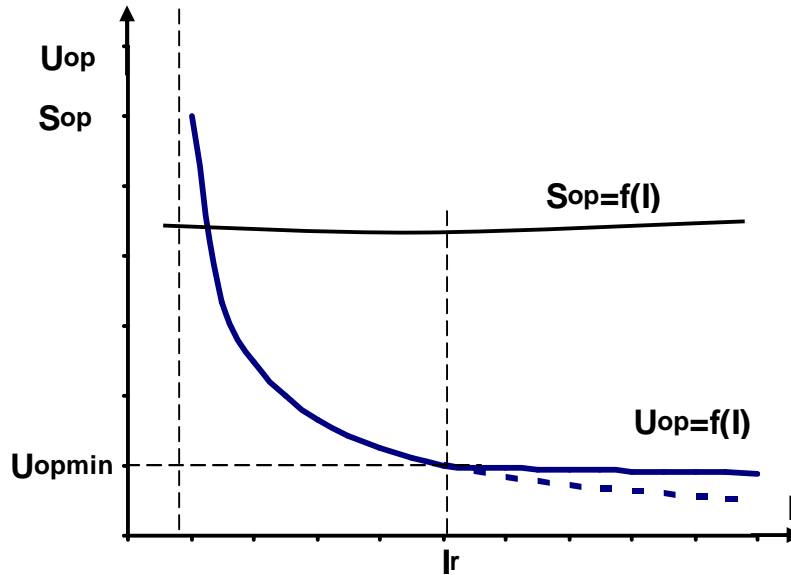

Fig. 11. Characteristic $U_{op}=f(I)$ and $S_{op}=f(I)$ for electromechanical directional relay as an example

These for $U_{op}=f(I)$ should be carried out immediately after having evaluated $U_{op}=f(\varphi)$ characteristic to avoid double scaling of the phase shifter. Under the test displacement angle between voltage and current should be kept constant and equal to RCA value (ψ) of the relay. First, relay should be energized by rated current value I_r and voltage must be increased slowly up by means of AT1 to the relay operation. The measurements must be performed 5-time and repeated for another current values. They have to be stopped for current at which operating voltage exceeds 50 V.

Table 2. Results of measurements of $U_{op}=f(I)$ characteristic

Directional relay: type....., No.....							
$I_r = \dots\dots\dots, U_r = \dots\dots\dots, \psi = \dots\dots\dots, \psi_{setted} = \dots\dots\dots$							
I	[A]						
U_{op} [V]	1						
	:						
	5						
U_{opa} [V]							
$S_{opa}=IU_{opa}$	[VA]						



THE DEVELOPMENT OF THE POTENTIAL AND ACADEMIC PROGRAMMES OF WROCLAW UNIVERSITY OF TECHNOLOGY

where: S_{opa} , U_{opa} – arithmetic average of operating apparent power and operating voltage respectively

Having determined characteristics $U_{op}=f(I)$ and $S_{op}=f(I)$ one can evaluate so called directional sensitivity of the relay $U_{s\%}$ according following formula:

$$U_{s\%} = \frac{U_{op\min}}{U_r} \cdot 100 \quad (7)$$

where: $U_{op\min}$ – minimum operating voltage for $I=I_r$ and $\varphi=\psi$,

U_r – rated voltage of the relay.

The smallest S_{op} value and directional sensitivity factor $U_{s\%}$ determine dead zone of a directional protection. They also allow for estimation a distance from location of a relay and 3-phase metallic short-circuit point in given network for which the directional relay does not operate.

3.3. Testing requirements for MiCOM P127 relay

3.3.1. Basic information

Modern digital relays of series MiCOM P127 (AREVA Company) are overcurrent directional relays of general-purpose application. They are multifunctional designed for 3-phase systems together with power and energy measurements. They provide protection for various supplying systems independently on neutral point grounding of transformers, and back-up function for the highest voltage networks as well. Due to application of microprocessor MiCOM P127 relays provide a high degree of flexibility and wide range of settings along with a variety of setting options (e.g. 3 independent functions for overcurrent and short-circuit protections, 3 different setting of ground fault protection, 12 different types of inverse time (dependent) characteristics (flexible selected by user, overload undercurrent negative sequence current, power, frequency as well as voltage functions). This relay can easy communicate with superordinated system by means of implemented protocols (MODBUS RTV or IEC 60970-5-103). Recorded data are stored in the relay memory (setting, measurements, events faults and its variation with time) and can be therefore easily transmitted to display event reports for analyzing the nature of disturbances and related performance of protection and interrupting devices. MiCOM P127 measures 3-phases currents and frequency. Data are accessible through as local as well remote program and displayed. Outputs and inputs are digital configurable and combination of operation thresholds are programmable independently for particular output.

3.3.2. Connection of MiCOM P127 as overcurrent directional relay

MiCOM P127 relay uses general recommendation if about relationship between current being measured and voltage. It is referred to as 90^0 connection what is illustrated in Fig 2.

THE DEVELOPMENT OF THE POTENTIAL AND ACADEMIC PROGRAMMES OF WROCLAW UNIVERSITY OF TECHNOLOGY

Before conduct the test one has to check if all output as well as input terminals are correct connected and supplied.

Therefore:

- provide auxiliary DC voltage of 110 V to terminals 33 and 34,
- current input (terminals 41 and 42) supply from current transformer and do not exceed acceptable short-circuit loading that is follows:

- continuous $4 \times I_n$
- 1 s $100 \times I_n$
- 2 s $40 \times I_n$

where $I_n = 5 \text{ A}$ is rated current

- voltage input (terminals 71 and 72) connect to phase shifter through autotransformer,
- relay output (terminals 8 and 10) connect to signaling light bulb and supply from DC source.

3.3.4. Test and measurement procedure

Typical circuit for testing of MiCOM P127 relay is quite similar for another directional relays and is presented in Fig 12. Before the test is carried out one has to read-out relay setting. Both reading and change of setting value is able to be performed by means of RS 232 port combined with PC or/and using screen and control panel of the relay.

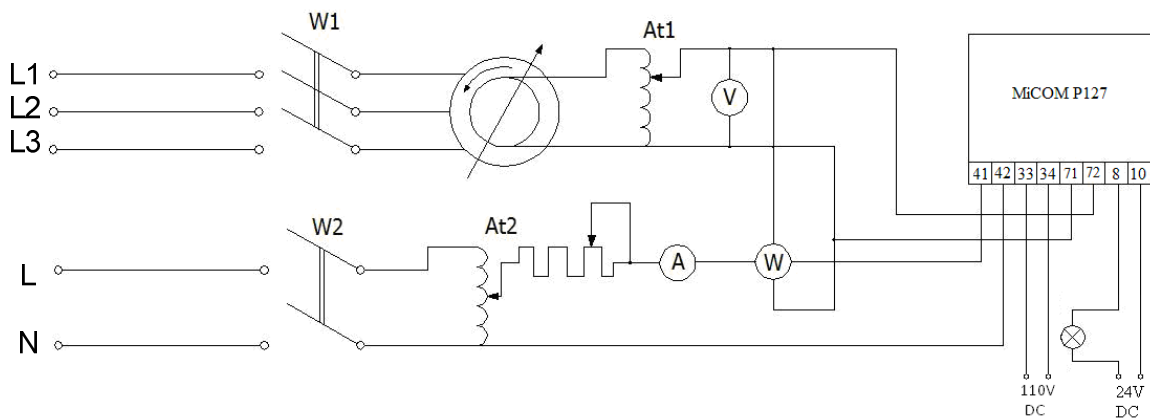

Fig. 12. Scheme of connections for testing of MiCOM P127 relay

To change, for example, time delay value use first “down” arrow (↓) next press arrow to “right” (→) until “Zabezpieczenie Grupa 1” (“Protection Group 1”) appears and next touch again “down” arrow (↓) to display $tI>$. Then, press “enter” confirm passwords with “enter” (AAAA), change the time setting in seconds and confirm with “enter” finally.

The measurement procedure of operating voltage versus current and angular characteristic are the same as for another electromagnetic relays selected for testing. However, for digital MiCOM P127



THE DEVELOPMENT OF THE POTENTIAL AND ACADEMIC PROGRAMMES OF WROCLAW UNIVERSITY OF TECHNOLOGY

relay each value of the phase shift between voltage and current can be observed on line on the screen. To do it one has install free “MiCOM S1” programs, connect with PC through RS 232 port using communication channel. Interface of software is sufficiently simple in use; contact the relay and select option either measurement or setting.

TASK No 6

INVESTIGATION OF DIFFERENTIAL RELAYS

Concise specification (manual)

1. Introduction – differential principle

Differential protection is one of the best protection techniques for more than 60 years. It is universally applicable to all parts of the power systems like: motors, generators, bar buses, transformers, lines and combination of these (like generator-transformer unit). The electrical quantities (mostly currents) entering and leaving protected area are compared by current transformers (CTs). If the net between all the various circuit is zero, it is assumed that no fault or intolerable disturbance exist. While, if it is not an internal problem exist and the difference current value can operate the associated relays or output measuring elements. In general, internal faults provide significant operating current, even for fairly light faults.

There are two types of differential protections in use: longitudinal (lengthwise) and transverse (crosswise). However, this last one is rather seldom employed and in this text is omitted. Principle of the current differential systems is shown in Fig 1, where for simplicity only two circuits in the protection zone are visible (for multiple current as well as voltage circuits the principle is the same).

For normal operation and all external faults, the secondary current in the protective relay (R) is the difference in secondary currents of the differentially connected current transformers:

$$I_p = I_a - I_b = \frac{I_A}{\mathcal{G}_{ia}} - \frac{I_B}{\mathcal{G}_{ib}} \approx 0 \quad (1)$$

where: \mathcal{G}_{ia} , \mathcal{G}_{ib} – rated turn ratio of CTs

THE DEVELOPMENT OF THE POTENTIAL AND ACADEMIC PROGRAMMES OF WROCLAW UNIVERSITY OF TECHNOLOGY

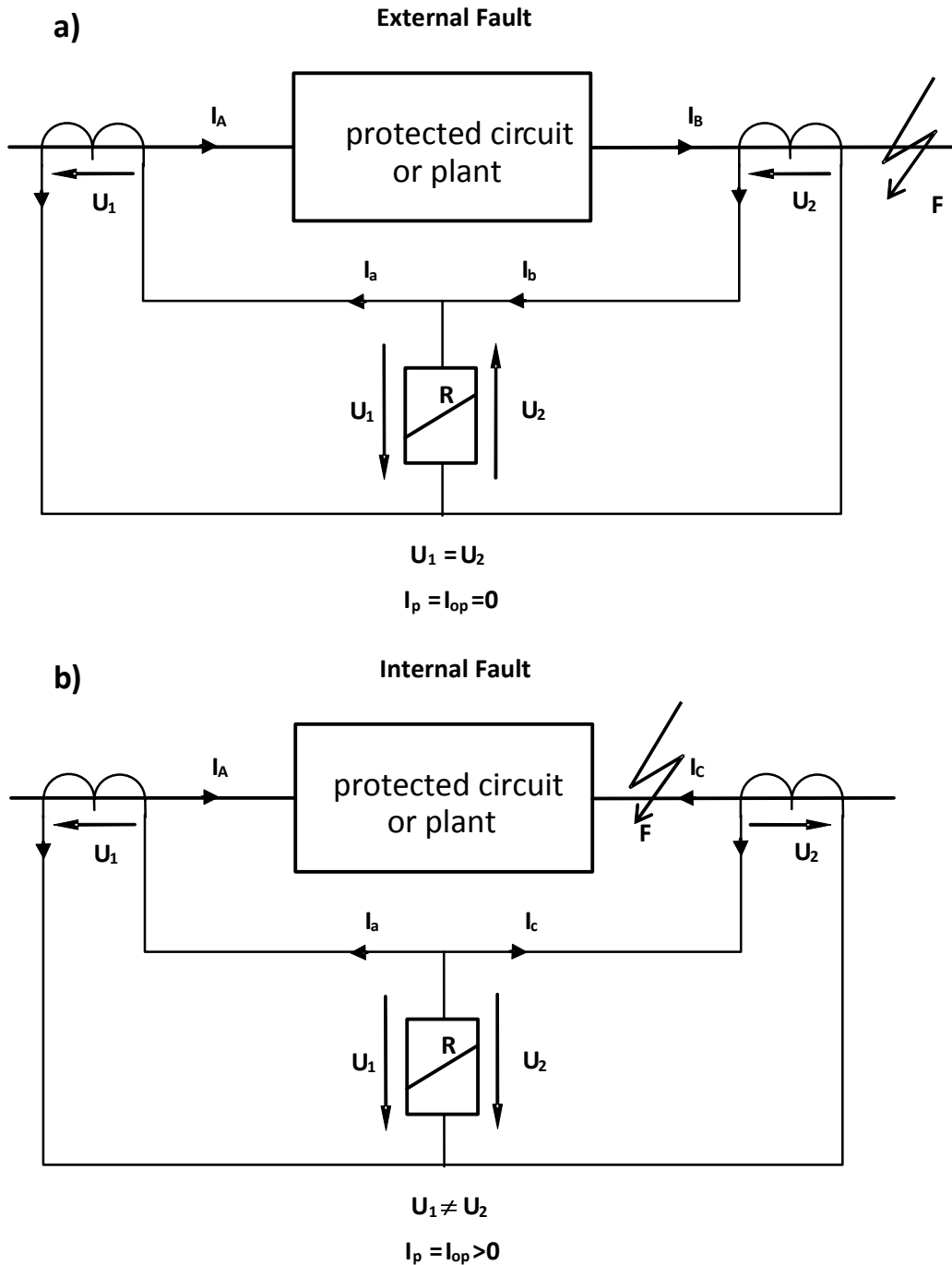

Fig. 1. Basic current differential scheme illustrated for the protection of a zone with two circuits: a) normal state or/and external fault, b) internal fault

However, one has to know that even with exactly the same ratio and type of current transformer, the relay current I_p will be small but never zero. This is because of the losses within protected area and small differences in magnetizing characteristics between the same CTs. With different CTs and ratios, larger differences will arise that must be minimized or the pickup of the relay



THE DEVELOPMENT OF THE POTENTIAL AND ACADEMIC PROGRAMMES OF WROCLAW UNIVERSITY OF TECHNOLOGY

(R) must be set so that it does not operate in any trough condition. Therefore, to decrease spill current value ($I_p \approx 0$) as much as possible a following requirement has to be met:

$$\frac{I_A}{g_{ia}} = I_a \approx \frac{I_B}{g_{ib}} = I_b \quad (2)$$

For equipments such as lines, generators, motors and so on, the current transformers usually are of the same ratio and of the same magnetic parameters so that:

$$\frac{g_{ia}}{g_{ib}} = 1 \quad (3)$$

Therefore, it is not too difficult to interconnect their secondary's with the relay. While for transformers one has to balance the secondary currents either by correction carried out numerically inside the relay (if modern digital relays are used) or by use so called interposing current transformers, it provides ratio correction for line CTs, transformer vector group (phase shift) correction and zero sequence trap to ensure stability for external earth faults.

During external disturbances (faults) the transient performance of the CTs due to the sudden increase in current and the DC component can involve large transient – operation currents. Therefore, an instantaneous relay (R) is not recommended. Even time-delay relays can be used with care.

For internal faults, in Fig 1b one can see that the differential relay operating current (I_{op}) is basically the sum of the input currents (I_A, I_C) feeding the fault, however, on a secondary ampere basis. Therefore, good discrimination is available to detect faults (problems) within the protected (differential) zone. To provide high sensitivity to internal faults of a small currents with a high security (high restraint) for external faults, most differential relays are of the percentage differential type (biased differential protection) – see Fig 2.

THE DEVELOPMENT OF THE POTENTIAL AND ACADEMIC PROGRAMMES OF WROCLAW UNIVERSITY OF TECHNOLOGY

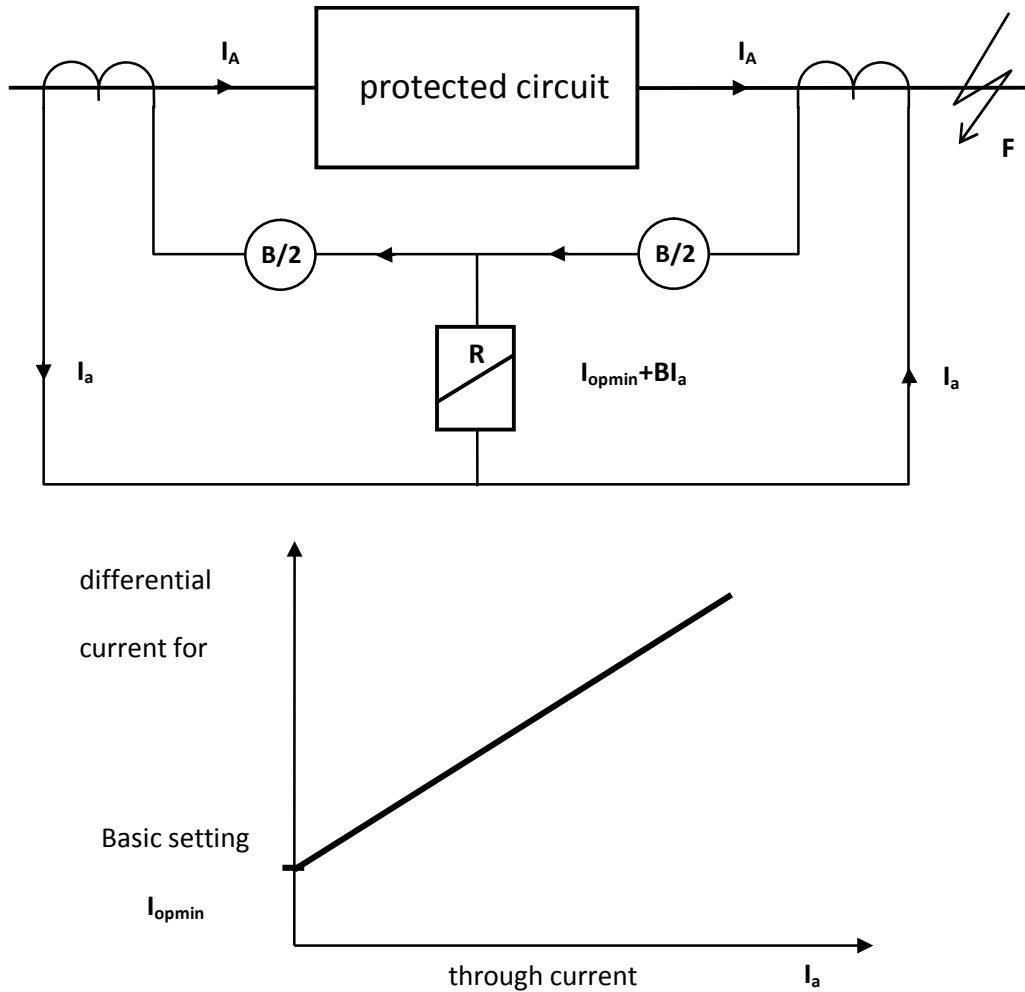

Fig. 2. Principle of operation of biased differential protection and operating characteristic

In this case at low through currents the slope (percentage bias) of the operating characteristic is low because at these levels the current transformer performance is usually quite reliable. At high through-fault currents, where the CT performance may not be as dependable, a high-percentage characteristic is provided. Therefore, bias characteristic compensates for mismatch between CTs secondary currents. Minimum operating currents increased in proportion to the level of through current what results in increased sensitivity with higher security. Usually the percentage bias exist between 10% and 50% and may have taps to change the percentage. Therefore, with a 50% characteristic, an external (or through) current of 10A requires a difference (or operating) current of 5A or more for the relay to operate. However, with a 10% for the same 10A current 1A already will produce relay operation.

Differential electromagnetic relays are equipped with three windings - two restraint and one operating respectively. The secondary of the CTs are connected to restraint windings and currents in these inhibits operation. The operating winding is associated with these restraint windings and current in this tends to operate the relay. This relays are calibrated with current through one restraint and the

THE DEVELOPMENT OF THE POTENTIAL AND ACADEMIC PROGRAMMES OF WROCLAW UNIVERSITY OF TECHNOLOGY

operating windings with no current through the other restraint. Typical pickup currents for differential relays are in the range of 0.14-0.3A depending on the type and application. However, in modern digital protection the operational characteristic is programmable.

The differential principle is also used for transmission lines at higher voltages. However, in these cases due to considerable distances between terminal and CTs a communication channel (pilot wire fiber-optic cable or wireless link) is used for information comparison between the various terminals.

Differential protection, however applicable, provides the best protection performance for both phase and ground faults, except in ungrounded systems or in conditions where the faults current is limited by high-impedance grounding.

Generally, differential protection is employed to transformer units of a higher power ($\geq 10\text{MVA}$). However, the key factor is the importance of the transformer in the system, so this protection may be desirable for smaller units to limit potential damages.

Application of differential protection to transformers requires special consideration for the effect of:

- magnetizing inrush current,
- differences in CTs ratios and performance characteristics,
- transformer vector grouping,

In a three-phase circuit some inrush will always occur, generally in all three phases, with the voltages at 120° apart when energized. The transient currents flow on one side, therefore produce a differential current. Peaks can be up to 30 x rated current value and it can take several seconds to decay completely (5-10s). As one can see from Fig 3, the magnetizing inrush current contains high degree of high harmonics: 30-70% of second, 10-30% of third and 40-60% DC component respectively. Therefore, the differential relay must include some feature to ensure stability when transformer is energized:

- “time delay”, undesirable since operation for genuine internal faults is also delayed (e.g. RQS-2, RQS-3 relays),
- “second harmonic restraint”, most common method,
- “wave recognition techniques” e.g. so called “gap detection”



THE DEVELOPMENT OF THE POTENTIAL AND ACADEMIC PROGRAMMES OF WROCLAW UNIVERSITY OF TECHNOLOGY

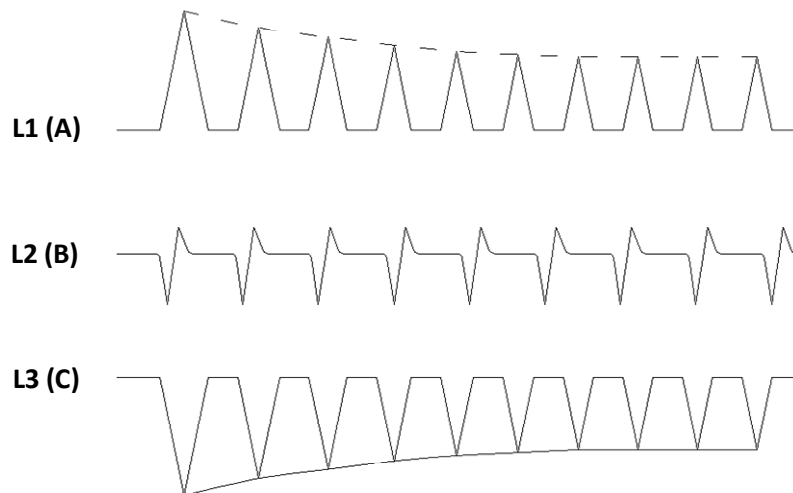

Fig. 3. Illustration of magnetizing inrush current when switch on transformer under out of load operation

However, differential protection can undesirable operate under overexcitation. The flux level within a transformer is proportional to the voltage applied (except saturation region) and inversely proportional to the frequency of the applied voltage.

Therefore, under overexcitation the transformer core becomes saturated resulting in a buildup of heat with eventual damage to the transformer. Overvoltage and underfrequency conditions can occur especially during startup of the generator. However, it can occur anywhere on the power system, especially when disturbances cause portions of the system to operate as isolated islands. Harmonic content of transformer excitation current is predominantly odd harmonic. Therefore, for example a fifth harmonic component is employed in some relay structure (like blocking feature in relay type RRTT-6, RRTT-7) to effective stabilization of the differential protection performance, or mechanical resonance as in TG type relays.

Modern microprocessor based transformer differential relays provide a high degree of flexibility for incorporating a multitude of design features (like easy communication link, fault recording etc). that were not formally possible with electromechanical devices.

Differential relays are designed among others with saturation discrimination to lower possibility of operation when current transformer saturation occurs during faults that are external to the zone protected. As a result differential current appears simultaneously with restraint current for internal faults. While, under external problems with increased current magnitude (resulting in saturation of current transformer) the differential current flows only when saturation occurs (e.g. MiCOM P631).



THE DEVELOPMENT OF THE POTENTIAL AND ACADEMIC PROGRAMMES OF WROCLAW UNIVERSITY OF TECHNOLOGY

2. Examination of electromechanical differential relays

Investigations are conducted for relay selected by responsible supervising person and involve:

- checking of current scale of a relay,
- determination of operating characteristics $I_{op}=f(I_h)$

2.1. Laboratory stand

General View of laboratory stand for testing of differential relays is seen in Fig 4.

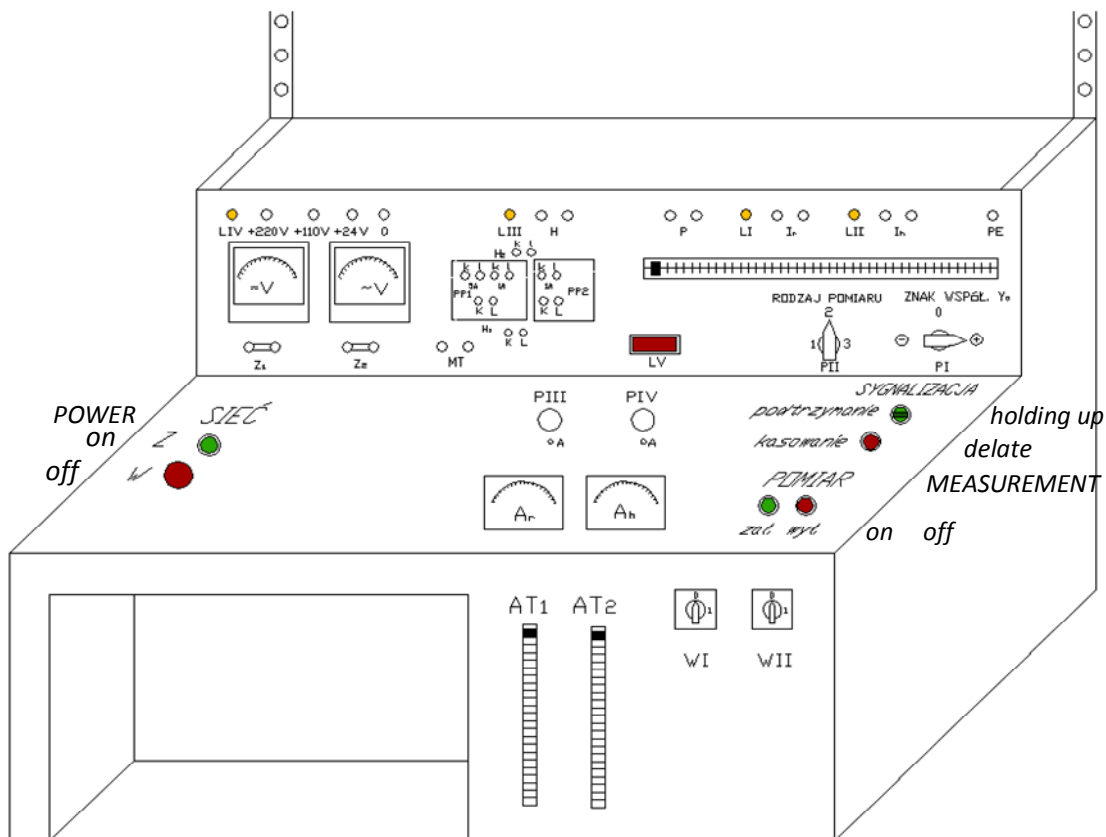

Fig. 4. General view of laboratory stand for testing differential relays

Electric power AC is delivered by two independent lines through autotransformers AT1 and AT2 to current value control. Each track is equipped with multi-range measuring current transformer with moving-iron ammeters (A_r – operation) and (A_h – restraint) respectively. The required current range of the ammeters is adapted by means of measuring transformers PIII and PIV. Respective output terminals are located on frontal part of a table and marked as I_r (operation current I_{op}) and I_h (restraint). A special system is also included to provide second harmonic of current of regulated magnitude (using Y_0 slider one can control relationship between magnitudes of DC and AC components energizing relay under test). Therefore, efficiency of blocking function of the relay when energizing the transformer can be checked successfully. Modern transformer differential relays incorporate microprocessor based

THE DEVELOPMENT OF THE POTENTIAL AND ACADEMIC PROGRAMMES OF WROCLAW UNIVERSITY OF TECHNOLOGY

testers and provide additional operational improvements. Such designs are able to provide reliable operation with sensitivities down to about 0.75A or less and with operating time within one cycle.

Basic technical data:

- rated currents (both restraint I_h and operation I_{op}) – 20A rms,
- rated current for relays under test – 5A or 1A,
- maximum value of DC load – 13A,
- maximum value of AC load – 40A

Using the laboratory stand following tests are able to be performed:

- a) Verification of energization values of relays (current-carrying scale),
- b) Operating differential characteristics $I_{op}=f(I_h)$,
- c) Immunity to magnetizing inrush current when energizing the transformer.

For functional tests three types of differential relays were selected and are mounted on the stand table:

- electromechanical: RQS-2 (AEG Company) and TG-3 (Brown Boveri Company),
- microprocessor based: MiCOM P631 (AREVA Company).

2.2. Selected differential relays

2.2.1. Electromechanical relay RQS-2 type

It is designed basically for differential protection of generators, however, conditionally for transformers as well. Both coils (operation and restraint) of the relay are of three phase type providing unilateral stabilization. Movable parts of magnetic systems are fixed on the same axis of rotation. Currents in restraint windings (coils) inhibit operation together with breaking torsional moment due to pull spring. If resultant moment due to currents in operating windings is larger then this generated by restraint currents the movable mechanical system is out of balance what results of its rotation and closure of output electrical contact. It gives operation of an auxiliary relay as a result. Operation current value is adjusted by control of the pull spring tension. Stabilizing coefficient value is fixed and equal to $k=0.45$. Internal connection for the RQS-2 type relay is indicated in Fig 5. Its technical data are as follows:

- rated current: $I_n = 5A$,
- operational current value: $I_{op} = (1.5 - 3)A$,
- power consumption
 - operating coil: 4 VA,
 - restraint coil: 2.5 VA.

THE DEVELOPMENT OF THE POTENTIAL AND ACADEMIC PROGRAMMES OF WROCLAW UNIVERSITY OF TECHNOLOGY

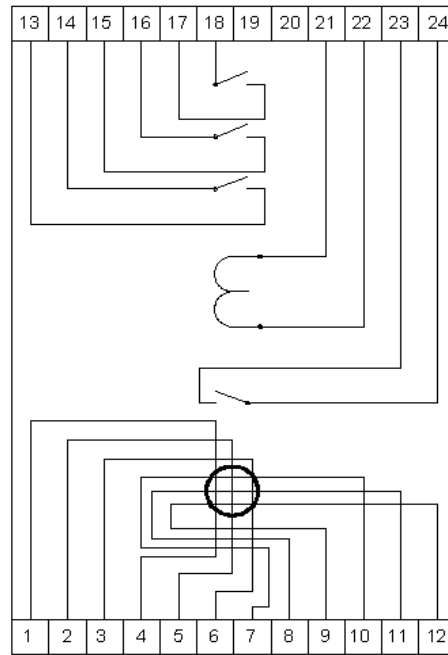

Fig. 5. Internal connection of RQS-2 relay

2.2.2. Electromechanical relay TG-3 type

It provides differential protection only for transformers. It is equipped with three phase separate mechanical systems with double-sided stabilization and blocking function for magnetizing inrush current effect. Restraint activity under transformer energization is performed by use of resonance phenomena of differential mechanical systems which are of rotational type. Schematic diagram of the TG-3 relay is presented in Fig 6.

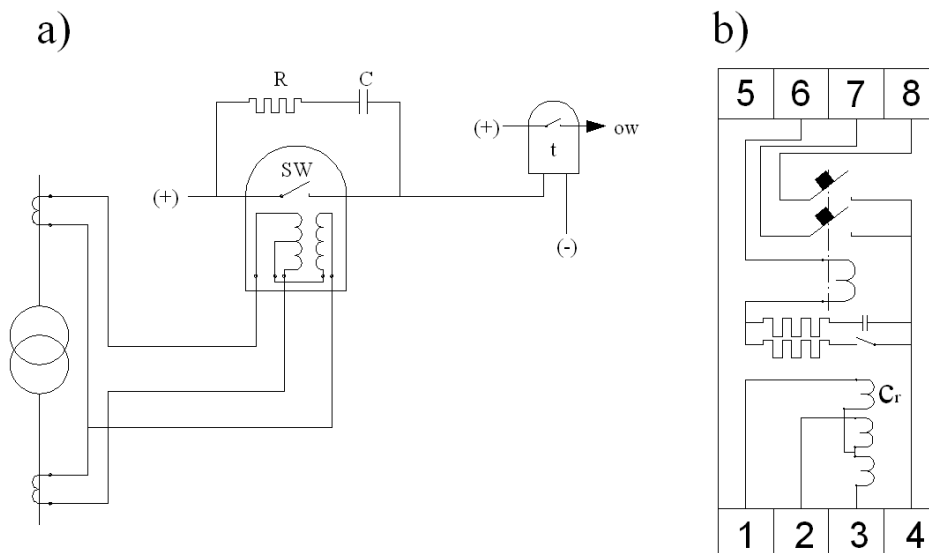

Fig 6. Schematic diagram of the TG-3 relay (a), SW – vibrating contact, R, C – elements of contact protection circuit, b) internal connection



THE DEVELOPMENT OF THE POTENTIAL AND ACADEMIC PROGRAMMES OF WROCLAW UNIVERSITY OF TECHNOLOGY

Each differential measuring movable system is composed of two identical armatures fasted to common axis of rotation. However, they are under influence of oppositely directed magnetic fields due to current flowing in operation and restraint windings respectively. The stabilizing factor value can be calibrated by respective taping of the restraint coil. While, the operate current is controlled by regulation of return spring tension. The mechanical rotational systems are designed to be in resonance state under influence of resultant driving magnetic moment of 50Hz. Therefore, during energization of the transformer due to influence of DC component the resultant driving moment varies in time with frequency of 50 Hz resulting in periodic opening and closure of electrical output contact. Because, of selected delay time value in order to operate out-put definite time relay (see Fig 6) the differential protection does not work under magnetic inrush current.

While for internal faults because of bidirectional flow of a short circuit current the resultant magnetic moment acting for the movable mechanic system is of 100 Hz (it is proportional to i^2). Thus, the output contact is reliable closed what provide reliable performance of the differential protection.

Basic technical data of the TG-3 relay are as follows:

- rated current: $I_n=5A,$
- operational current value: $I_{op}=(0.2-0.4)I_n,$
- stabilizing coefficient: $k_n=0.1-0.5,$
- delay time of definite time relay: $(0.05-0.3)s.$

2.2.3. Microprocessor based relay (MiCOM P631 – AREVA)

Provides quick and selective differential protection of transformers, motors, generators and other installations with two windings. Differential protection MiCOM P631 is of modular construction. Its schematic diagram is seen in Fig 7.

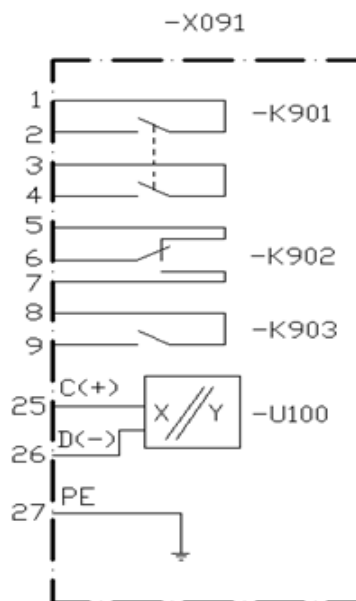

Fig. 7. Schematic diagram of the MiCOM P631 relay (internal wiring diagram of module contacts)

THE DEVELOPMENT OF THE POTENTIAL AND ACADEMIC PROGRAMMES OF WROCLAW UNIVERSITY OF TECHNOLOGY

The relay has the following functions:

- Three-system differential protection for protected objects with two windings,
- Amplitude and vector group matching,
- Zero-sequence current filtering for each winding, may be deactivated,
- Triple-slope tripping characteristic,
- Inrush restraint with second harmonic, optionally with or without global effects; may be deactivated,
- Overfluxing restraint with fifth harmonic component, may be,
- Through-stabilization with saturation discriminator,
- Definite-time overcurrent protection (three stages, phase-selective, separate measuring systems for phase currents, negative-sequence current and residual current),
- Inverse-time overcurrent protection (single-stage, phase-selective, separate measuring systems for phase currents, negative-sequence current and residual current),
- Thermal overload protection, choice of relative or absolute thermal replica,
- Limit value monitoring,
- Programmable logic.

Technical data of MiCOM P631 relay are as follows:

- Measurement inputs:

Current:

Rated current:	$I_n = 1$ or 5 A AC (adjustable),
Rated power consumption per phase:	<0.1 VA at I_n ,
Rated load:	
continuous:	$4I_n$
for 10s:	$30I_n$

Voltage:

Rated voltage:	$U_n = 48$ to 130 V AC (adjustable),
Rated power consumption per phase:	<0.3 VA at $U_n=130$ V AC,
Rated load continuous:	150 V AC

Frequency:

Rated value:	$f_n = 50$ Hz and 60 Hz (adjustable),
Operating range	
protection function:	40 to 70 Hz
another function:	$(0.95$ to $1.05)f_n$

- Binary input signals:

THE DEVELOPMENT OF THE POTENTIAL AND ACADEMIC PROGRAMMES OF WROCLAW UNIVERSITY OF TECHNOLOGY



Rated auxiliary voltage: $U_{dn} = 48$ to 250 V DC,

Operating range: $(0.8$ to $1.1)U_{dn}$ with a residual ripple
of up to $12\%U_{dn}$,

Before turning on the power supply voltage, the following items must be checked:

- a) Is the device connected to the protective ground at the specified location?
- b) Does the nominal voltage of the battery agree with the nominal auxiliary voltage of the device?
- c) Are the current and voltage transformer connections, grounding, and phase sequences correct?

Once all checks have been made, the power supply voltage may be turned on. After voltage has been applied, the device starts up. During startup various startup tests are carried out. The LED indicators for operation (H1) and Blocked/Faulty (H2) will light up. After approximately 15 s the P631 is ready for operation. This is indicated by the display "P631" in the first line of the LCD display.

Before testing of MiCOM P631 one has to made its settings according to requirements of supervising person. The steps and sequence for adjusting are presented in Table 1. Any disruption indicates inflammation of the red LED labeled "Trip". Before each measurement, the state must reset the device a combination of buttons  → .



THE DEVELOPMENT OF THE POTENTIAL AND ACADEMIC PROGRAMMES OF WROCLAW UNIVERSITY OF TECHNOLOGY

Table 1. Entering the security settings for the differential protection MiCOM P631

Steps	Menu item	Position	Value
1	Parameters → Config.parameters → DIFF	Function group DIFF	1 or [+] (= With)
2	Parameters → FunctionParameters → Global → PSS	Control via USER	Yes
		Param.subs.sel. USER	Parametr subset 1
3	Parameters → FunctionParameters → PSS → DIFF	Enable	Yes
		Idiff>	$a \cdot I_{ref}$
		Idiff>>	$a \cdot I_{ref}$
		Idiff>>>	$a \cdot I_{ref}$
		IR,m2	$a \cdot I_{ref}$
		RushI(2f0)/I(f0)	%
		Ov. I(5f0)/I(f0)	%
Op.del.,trip sig.	s		
4	Parameters → FunctionParameters → General Functions → DIFF	General enable USER	Yes
5	Parameters → Config.parameters → MEASO	Function group MEASO	1 or [+] (= With)
		General enable USER.	Yes
6	Parameters → Config.parameters → OUTP	Fct. assignm. K 901	DIFF trip signal
7	Parameters → FunctionParameters → Global → MAIN	Device on-line	Yes (=on)

THE DEVELOPMENT OF THE POTENTIAL AND ACADEMIC PROGRAMMES OF WROCLAW UNIVERSITY OF TECHNOLOGY

Description of items:

1) Step 1

- a) Function group DIFF - Canceling function group DIFF or including it in the configuration.

If the function group is cancelled, then all associated settings and signals are hidden, with the exception of this setting.

2) Step 2

- a) Control via USER– control device settings from the *parameter subset*,
b) Param.subs.sel. USER - Selection of the parameter subset from the local control panel.

3) Step 3

- a) Enable – This setting specifies the parameter subset to be enabled for differential protection.

Idiff> - Operate value of the differential protection function as referred to the reference current of the relevant transformer,

- b) Idiff>> - Threshold value of the differential current for deactivation of the inrush stabilization function (harmonic restraint) and of the overfluxing restraint,

- c) Idiff>>> - Threshold value of the differential current for tripping by the differential protection function independent of restraining variable, harmonic restraint, overfluxing restraint and saturation detector,

- d) IR,m2 – This setting defines the second knee of the tripping characteristic. Above this knee, the gradient is m2,

- e) RushI(2f0)/I(f0)- Operate value of the inrush stabilization function (harmonic restraint) of differential protection, as ratio of the second harmonic component to the fundamental wave for the differential current, in,

- f) Ov. I(5f0)/I(f0)- Operate value of the overfluxing restraint of differential protection as ratio of the fifth harmonic component to the fundamental wave for the differential current, in percent,

- g) Op.del.,trip sig.– delay of the signal off.

4) Step 4

- a) General enable USER - Disabling and enabling the differential protection function..

5) Step 5

- a) Function group MEASO – configuration or removal of functional groups,
b) General enable USER- Disabling and enabling the differential protection function.

6) Step 6

- a) Fct. assignm. K901– assign a signal to the relay output configuration.

7) Step 7



THE DEVELOPMENT OF THE POTENTIAL AND ACADEMIC PROGRAMMES OF WROCLAW UNIVERSITY OF TECHNOLOGY

a) Device on-line – discontinuation or switching device.

2.3. Method of testing

Prior to measurement connect input terminals of operation winding with I_r (I_{op}) terminals and restraint winding terminals of the relay with I_h terminals of the table respectively according to schematic in Fig 8. Next supply relay with auxiliary voltage (DC), connect a made contact of the relay output to “P” terminals (on the table) to have signalling of operation and switch on main breakers marked as WI and WII> For DC supply lamp LIV will light up as well as voltmeter “V” will indicate it by swinging of a pointer while, for AC energization an engage pressbutton marked “off” (“wył”) will signal it (visual signalling) together with one of lamps LI, LII, LIII (depends on switch PII position). Voltmeter “~V” starts to be sensitive for AT1 regulation.

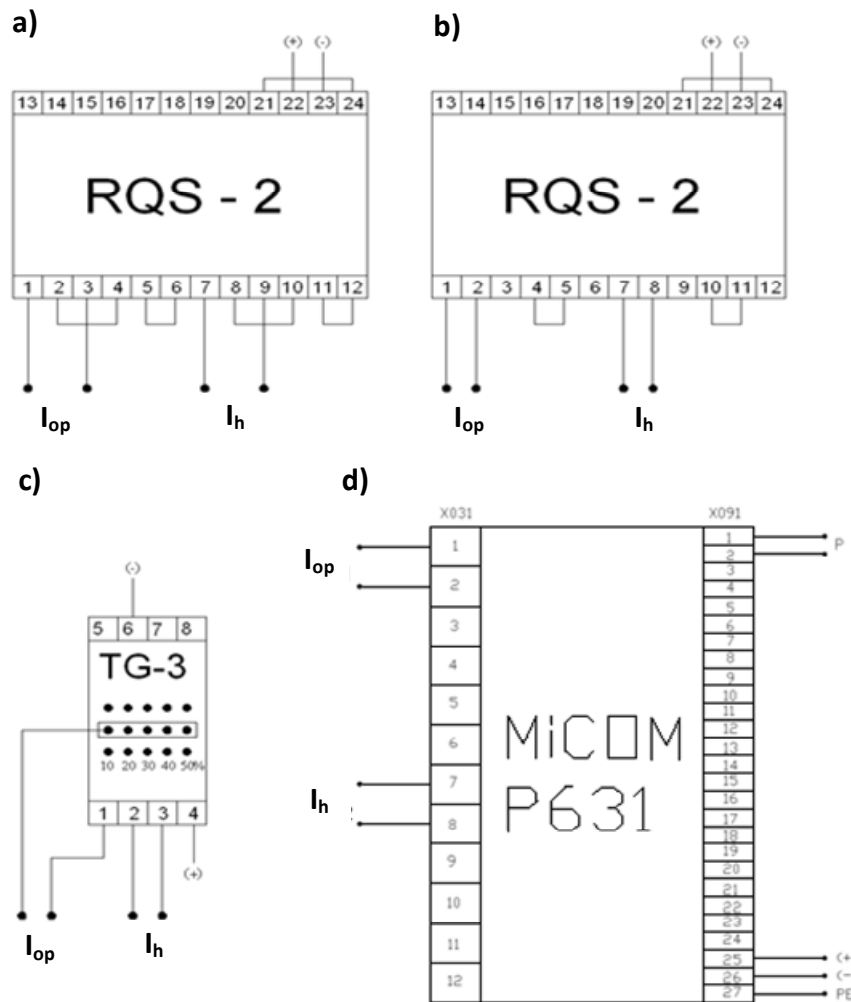

Fig. 8. Schematic diagram of measuring systems for testing differential relays: a) relay RQS-2 supply of three phases, b) relay RQS-2 (two phases supply), c) relay TG-3, d) relay MiCOM P631



THE DEVELOPMENT OF THE POTENTIAL AND ACADEMIC PROGRAMMES OF WROCLAW UNIVERSITY OF TECHNOLOGY

2.3.1. Verification of scale of current-carrying capacity of a relay

Set-up a change-over switch PII in position 1. It indicates selection of an operation winding (I_{op}) I_r of the relay only (lamp L1 will light up). After zero setting of autotransformer AT1 press button (“on”) “zał” to supply measuring current. It will be indicated by lighting up of this pressbutton (“on”) “zał”. Next, using switch PIII select required measuring range of ammeter (A_{op}) A_R and by means of the AT1 autotransformer adjust in turn necessary rms values of current (I_{op}) I_r in operation winding to check the scale of current-carrying capacity of relay under test. Operation of the relay is signaled by lamp LV. Verification of the scale must be performed for all operational values marked numerically. For TG-3 relay each phase has to be checked independently. To switch off the supply press button “wył” (off)

Attention: under optional variation of current value in measuring circuits it is recommended to perform testing for switched off holding up function in signalling circuit. On the contrary, the holding up should be activated when use step way current variation (short time operation of the relay under test is easily detected). Therefore, one has to press button (hold on) “podtrz” what is indicated by signalling of both buttons (hold up) “podtrz” and (“clearance”) “kas” respectively. After each operation of the relay (lamp LV lights up) to clear signaling press button (“clearance”) “kas”. It does not deenergize the hold up function. However, to clear it pressing (“clearance”) “kas” has to be repeated.

It must be noted that RQS-2 relay has to be tested under three phase supply (resultant moment of movable electromechanical system is due to three phases). Since, the lab stand is equipped only with one phase therefore, one has connect in series either all three phases of the relay (two coils in series, one in opposing connection I_{op3} – see Fig 8a) or only two coils (in opposing I_{op2} as in Fig 8b) under test respectively. However, the obtained investigated results for RQS-2 relay have to be referred to 3-phase supply I_{3op} as follows:

$$- I_{3op} = \frac{I_{op3}}{1.06} \quad \text{for 3 coils in series}$$

$$- I_{3op} = \frac{I_{op2}}{1.22} \quad \text{for only 2 coils}$$

On the basis of measuring results respective values must be listed in Table with indication of operate values I_{opn} (fixed on the scale), measured values I_{op} as well mean values (I_{opmean}) and calculated scale error.

2.3.2. Derivation of operation characteristics $I_{op}=f(I_h)$

Set up change-over switch PII in position 2 to supply both operation as well as restraint winding of the relay. Both lamps LI and LII will light up. Operational characteristic is verified for only one, selected operational current value. However, the operational current I_{op} must be measured



THE DEVELOPMENT OF THE POTENTIAL AND ACADEMIC PROGRAMMES OF WROCLAW UNIVERSITY OF TECHNOLOGY

for at least six different values of restraint current I_h selected from the range $I_h=0$ up to 3 rated value of the relay under test.

For RQS-2, as before, the operational value is measured for one phase supply therefore, it must be respectively referred to 3-phase value (I_{3op}). Having measured the operation characteristics, value of stabilizing factor can be derived.

TASK No 7

INVESTIGATION OF DISTANCE RELAYS

Concise specification (manual)

1. Introduction

1.1. General information

Distance relays provide protection against both phase-to-phase and ground faults for lines at 110 kV and higher. They compare the power system voltage and current operating when the ratio is less than its preset value. Since this ratio of the voltage to current applied to the relay is the impedance Z_m of the circuit ($Z_m = \frac{U}{I}$) thus, these relays are set as a function of the given impedance of the power system for the zone they should protect. To assure selectivity of the distance protection its time operation depends on distance to the faulty place (measured impedance Z_m mostly is reactance X). It is illustrated for example in Fig 1 for distance protection utilizing plain impedance relay, main impedance and directional elements which are combined to provide 3 stages of measurements. For a stage III (fault point F) the directional element operates, removes the control from the measuring relay and energizes two timing relays (stage II and stage III time lags).

THE DEVELOPMENT OF THE POTENTIAL AND ACADEMIC PROGRAMMES OF WROCLAW UNIVERSITY OF TECHNOLOGY

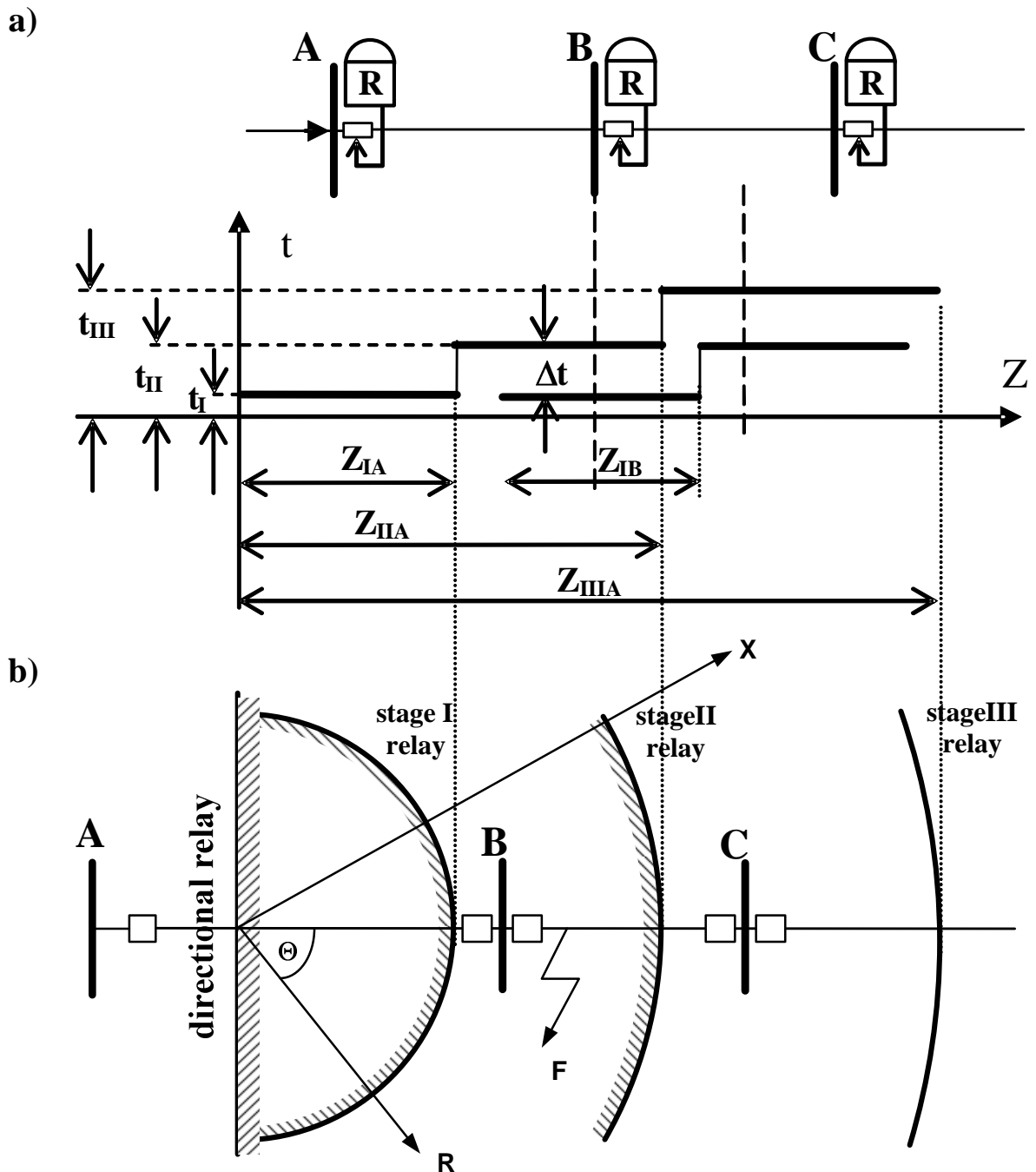

Fig. 1. Distance protection utilizing plain impedance relays; a) time-impedance characteristics, b) plain impedance characteristics, Z_r – impedance stages range, Δt – time lag,

Because the fault is beyond the reach of stage I relay no operation occurs. When the stage II time lag runs out, the setting of the impedance element is also beyond this reach. Only when stage III time lag runs out and the setting adjusted to the stage III reach does relay operation occur and tripping of the breaker at A takes place (It assumes that the fault is not cleared by the protection at B otherwise, the distance protection installed at B would clear this fault with t_I time by switching off the circuit

THE DEVELOPMENT OF THE POTENTIAL AND ACADEMIC PROGRAMMES OF WROCLAW UNIVERSITY OF TECHNOLOGY

breaker at B). It is possible to have not only more stages of measurement but also separate measuring elements for each stage. Usually t_I is fixed to be zero thus, it is so called “fast stage” (operates immediately). For two-sided power supply additional distance relays at B and C must be applied respectively. They can have the same characteristics but at reverse direction. Typically stage I (zone I) is set for around 90% (range 80 – 95 %) of the positive-sequence line impedance, stage II (zone II) approximately 30 – 50 % into the next adjacent line and stage III (zone III) approximately 25% into the adjacent line beyond. The possible zones II and III provide backup for all the adjacent lines at operating times of t_{II} and t_{III} respectively.

1.2. Structure and characteristics of the distance relays

1.2.1. General structure

The distance relay is composed of many different elements (functional units) among others of:

- operational threshold sensing unit,
- measuring unit,
- directional-sensing element,
- timing unit,
- logic function system,
- external as well internal signaling elements,
- tripping unit (contact output),
- setting unit,
- convertors of measuring quantities,
- self-reclosing system,
- power swing blocking unit (balanced conditions),
- coupling system with high frequency channel.

Modern microprocessor based distance relays provide greater flexibility, more adjustable characteristics, increased range of sensitivity, high accuracy, reduced size, lower costs and another functions (like control logic, event recording, fault location data, remote setting, self-monitoring etc) with compare to electromechanical relays. The protection function is available using microprocessor technology, however, the basic protection characteristics are essentially the same for both electromechanical and microprocessor relays.

Simplified block diagram of one measurement system distance relay is presented in Fig 2.

Under faults within protection zone of the line the operational units (UR) start to operate due to the increased (short-circuit) current as well as decreased voltage values of the faulty phases. They provide energization of the logical-selection elements (ULWI, ULWU) what in turn result in adjustment of voltage as well as current value suitable for the measuring (UM) and directional-sensing

THE DEVELOPMENT OF THE POTENTIAL AND ACADEMIC PROGRAMMES OF WROCLAW UNIVERSITY OF TECHNOLOGY

(UQ) element. Simultaneously, the time and setting unit (T+B) starts to perform time-impedance characteristics for the time being (particular stage selection). For the setting adjusted to the faulty point the output unit (UE) provides tripping of the circuit breaker and switching-off the faulty line as a result. Information of the distance protection operation is also displayed and signaled respectively. For any faults behind the relay location its operation is blocked automatically by the directional-sensing element (UQ).

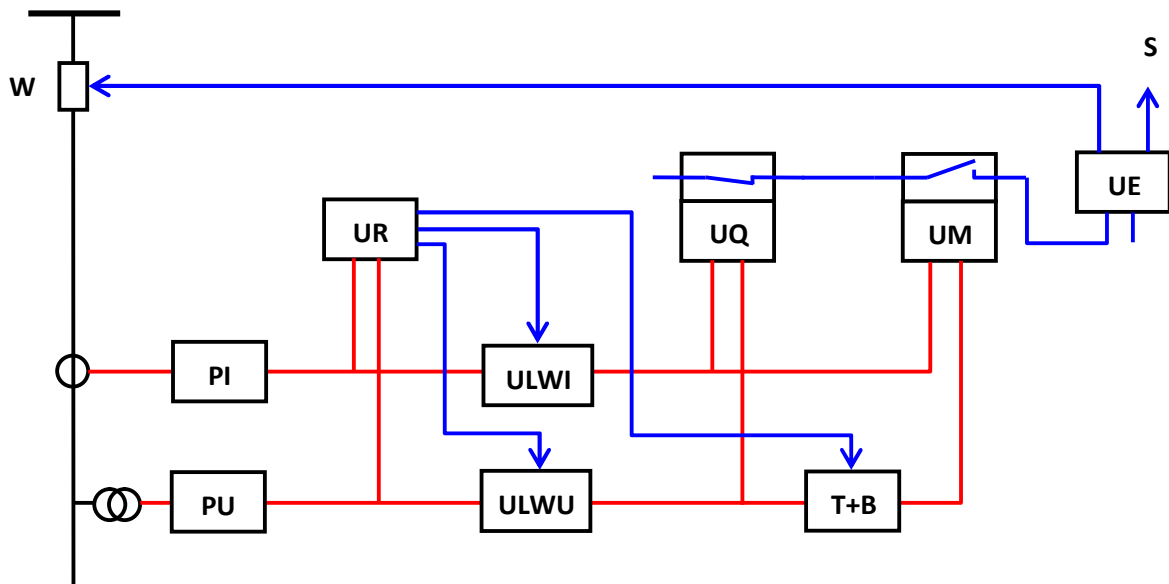

Fig. 2. Block diagram of one measurement system distance relay; PI, PU – current and voltage convertors, UR – operational unit (over-current or under-impedance), ULWI, ULWU – logical function-selection elements, T+B – time setting unit (voltage and impedance zone), UQ = directional-sensing-element, UM – measuring unit, UE – output and tripping block

1.2.2. Operational threshold sensing unit

It can be over-current (for middle voltage networks) or impedance (under-impedance) (for transmission and transmission-distribution lines) type.

The over-current threshold is not recommended for only use in MV transmission and/or distribution lines since minimum short-circuit value is comparable with this under maximum loading. However, for particular cases the instantaneous current energizing elements can be employed successfully. Their setting is the same as for time-over-current relays. The operational threshold sensing units should meet following requirements:

- reliable operation under faults at any point of the line being protected as well as at faults in adjacent line,
- high resistivity for unbalanced conditions of the line (power swing, etc),
- operate and identify correctly type of the fault for distance relays with one measuring system.



THE DEVELOPMENT OF THE POTENTIAL AND ACADEMIC PROGRAMMES OF WROCLAW UNIVERSITY OF TECHNOLOGY

Impedance (under-impedance) operational threshold sensing units control (and measure) the line impedance value on line. Their reliability (assurance that the protection will perform correctly) however is much lower to this of measuring units of the distance relay. In the relay with one system unit the threshold element is equipped with 3 impedance systems (separate for each phase) completed with zero-sequence detecting element. It changes over the impedance units for phase-voltage measurements in case of ground faults.

Characteristics of the impedance unit as well as the measuring system for the distance relay are displayed usually on complex plane. They represent curves that indicate (restrict) operation zone of a given measuring element. The location of the impedance characteristic on the complex plane as well as shape should be selected depending on so called characteristic impedance (Z_r). It can not coincide also with area of nominal line impedances (Z_n). The main purpose of the characteristic impedance Z_r is to ensure correct orientation of the impedance measuring characteristic in relation to the short-circuit impedance Z_1 of the protected circuit. Best performance, particularly in terms of operating speed is achieved at characteristic angle Θ indicating location of the impedance vector of the protected circuit. This phase-shifting affects the dynamic properties of the distance relay therefore, type and location of the impedance on the complex plain is important. Typical characteristics are selected in Fig 3, where prohibited areas depicting possible location of the nominal line impedance vector Z_n are indicated by dotted lines. The zone of the measuring characteristic (towards to nominal line value Z_n) is not allowed to be over the impedance for healthy phase (under phase-to ground faults) when taking into account so called “unbalanced current” I_w . Z_r thus can be calculated from following formula:

$$Z_r < \frac{U_{n.min}}{\sqrt{3}(I_{m.max} + I_w)} \quad (1)$$

where: U_{nmin} – minimum value of the healthy phases under the phase to ground “close” faults (about $0.85 U_n$).



THE DEVELOPMENT OF THE POTENTIAL AND ACADEMIC PROGRAMMES OF WROCLAW UNIVERSITY OF TECHNOLOGY

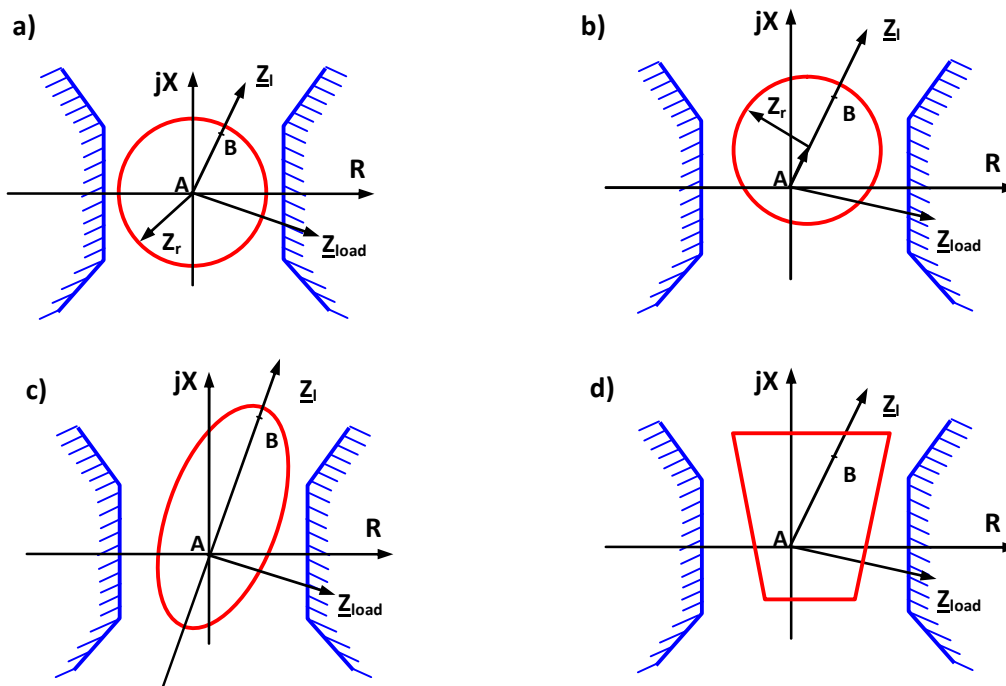

Fig. 3. Distance relay characteristics on the R-X diagram; Z_r – characteristic impedance, Z_i – short-circuit impedance, a) for lines below 100km, b) for lines of around 100km, c) d) – lines over 100km

1.2.3. Measuring unit

The operating circles (curves) must be set such that they do not operate on any system swings from which the system can recover. They should be also resistive to influence of factors that can make the impedance measurements not correct. It is particularly important under single-phase-to-ground faults since fault resistance R_p is non-linear especially during fault arcs. Therefore, there have been several HV and MV lines for which the ground distance relays did not respond properly (influence of the ground fault resistance R_p on result of the measured impedance Z_m is illustrated in Fig 4).

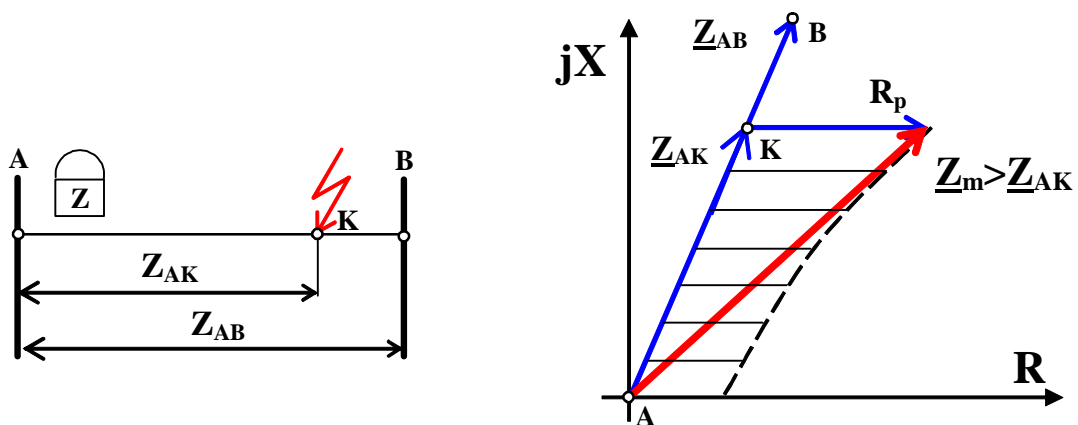

Fig. 4. Variation of the measured impedance Z_m due to ground fault resistance R_p

THE DEVELOPMENT OF THE POTENTIAL AND ACADEMIC PROGRAMMES OF WROCLAW UNIVERSITY OF TECHNOLOGY

Thus, ground distance protection should be supplemented with directional over-current ground relays. The influence of the ground-fault resistance can also be reduced by proper selection of the impedance characteristic shape to be extended along the R axis. The most useful is this case quadrilateral and/or reactance characteristic which are shown in Fig 5.

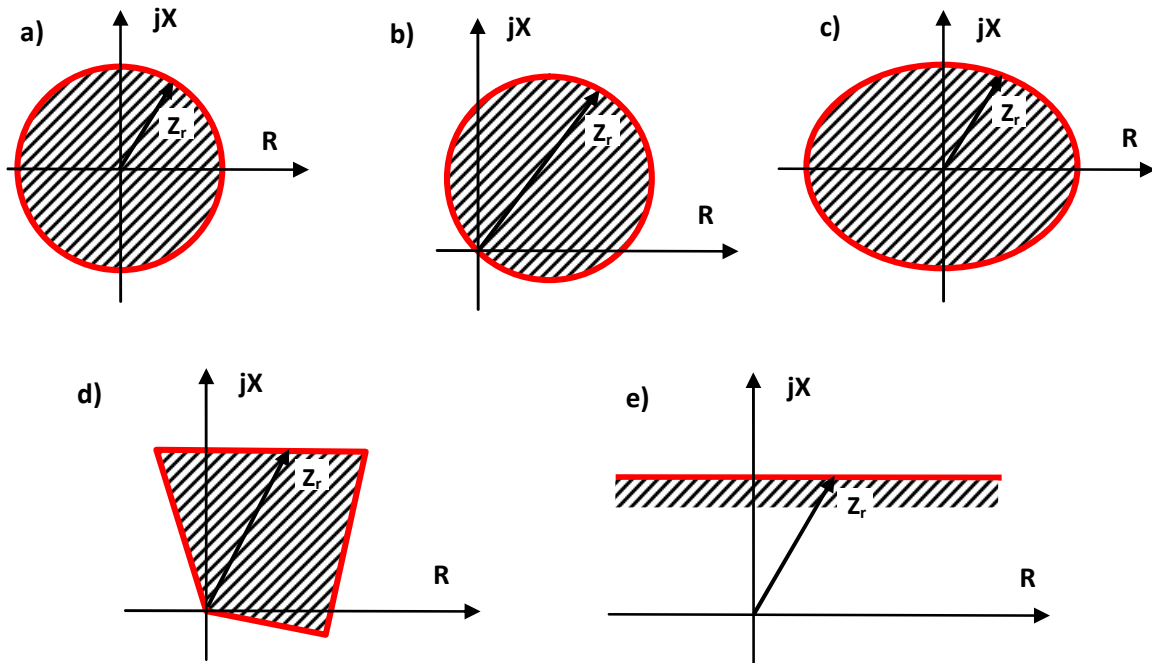

Fig. 5. Selected distance characteristics: a) plain impedance, b) mho, c) elliptical, d) quadrilateral, e) reactance

To make results of measurements to be independent on type of faults one has to provide such voltage and short-circuit current values to get as a result positive sequence line impedance ($Z_m = Z_l$). It will be fulfilled if during the phase-to-phase faults one applies phase-to-phase voltages and currents of the faulty phases while, for the ground-faults – the phase voltage and the short-circuit current together with respective contribution of the ground fault current respectively.

1.2.4. Directional sensitive element

To avoid mal-operation of the distance protection for faults located “behind” the relay a directional unit must be used to block tripping in case of the reverse short-circuit power flow from the line to the busbar. It is necessary for the protections that display non-directional characteristic like the plain impedance (see Fig 6).

THE DEVELOPMENT OF THE POTENTIAL AND ACADEMIC PROGRAMMES OF WROCLAW UNIVERSITY OF TECHNOLOGY

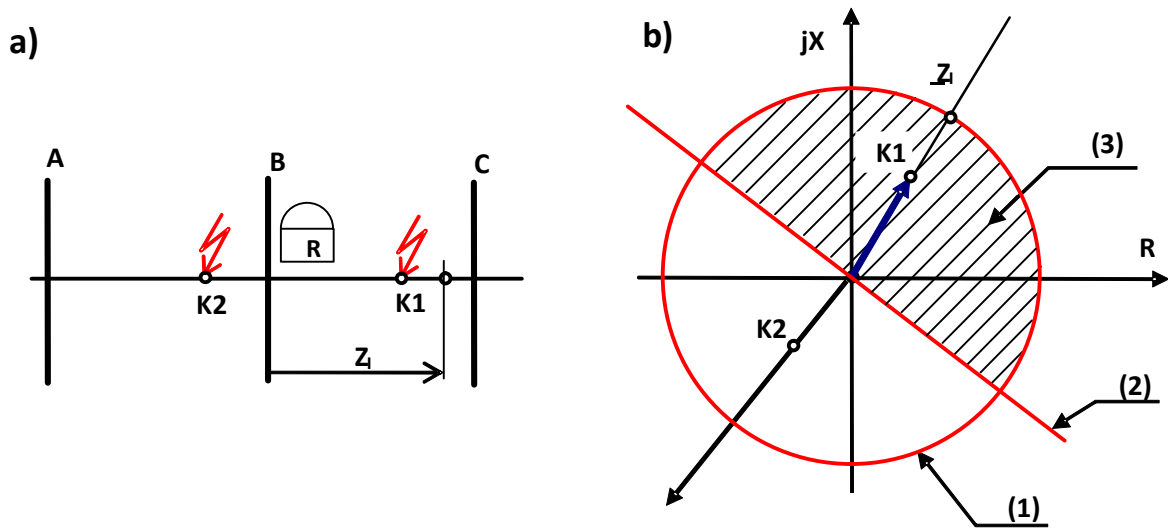

Fig. 6. Explanation of role of a directional-sensing unit; a) scheme of line being protected (R – distance relay to protect BC line distance, K1, K2 – fault locations), b) operational threshold characteristic (1 – plain impedance characteristic, 2 – directional characteristic, 3 – zone of operation)

The distance protection installed at the station B (Fig 6a) should provide reliable protection of the line for faults within BC area (e.g. fault at K1 point). On the complex plane diagram (Fig 6b) these faults are found as K1 vector location within first quarter, what results in correct operation of the relay. However, to avoid maloperation at K2 point (no protected are behind the relay) one has to apply additional directional-sensing element. Its characteristic is indicated by straight line (2) in Fig 6. As a result the protection will be blocked for all external faults depicted by location of the measured impedance vector to left of the characteristic. Very good results are obtained when replace the plain impedance by MHO characteristic (see Fig 5b). The admittance (MHO) is inherently directional and the offer MHO provides the best fault coverage and it is relatively immune to high load conditions and power swings.

1.2.5. Timing unit

Timing unit provides operation of the distance protection with the step way variation of the time-impedance dependent characteristics of particular stages (Z_I, Z_{II}, Z_{III}). It removes the control from the measuring relay and energizes respective timing relays with selected time-lag. The time grading Δt is in range 0.3 – 0.5s. Usually t_I is fixed to be 20 – 50 ms (instantaneous operation).

THE DEVELOPMENT OF THE POTENTIAL AND ACADEMIC PROGRAMMES OF WROCLAW UNIVERSITY OF TECHNOLOGY

2. Investigation of distance relays

2.1. Electromechanical relay type R1KZ4

2.1.1. Structure, principle of operation and basic parameters

The distance relay (R1KZ4, Siemens) provides protection for compensated as well as isolated MV networks. It uses measuring over-current detectors (relays) as operational threshold sensing units to trip circuit of the distance relay. Since, selection of impedance characteristic is available (like; plain impedance, conductance or mixed) therefore, the relay may be applied both for overhead and cable lines. General view of the R1KZ4 is seen in Fig 7, while its functional block diagram in Fig 8 respectively.

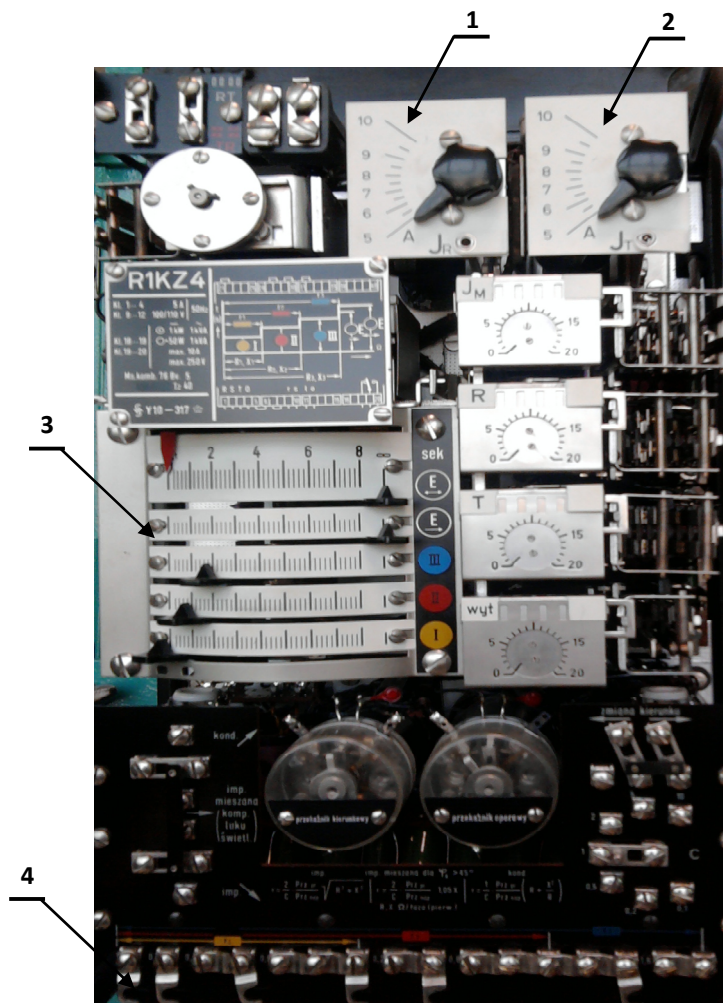

Fig. 7. General view of the R1KZ4 type relay (Siemens); 1, 2 - over-current threshold sensing units I_R and I_T , 3 – scale for timing unit, 4 – shunting clamps

Fault current will cause the over-current relays (I_R or/and I_T depends on the fault type) to operate what, in turn will energize the timing element and auxiliary relays of the logical function-selector (ULWU) unit. The (ULWU) unit is responsible for logical tripping of measuring circuits



THE DEVELOPMENT OF THE POTENTIAL AND ACADEMIC PROGRAMMES OF WROCLAW UNIVERSITY OF TECHNOLOGY

(voltage and current at secondary windings of intermediate transformers) to provide right (selected depending on the fault type) signals to the measuring (UM) and directional-sensing (UQ) unit. Simultaneously, the timing unit controls energization of the measuring unit to provide the required time-impedance characteristic according to setting. The directional-sensing element operates with so called inherent initial selectivity being equipped with normally closed (NC) output contact, what permit the circuit breaker (W – Fig 8) tripping for the (UQ) no-energized state.

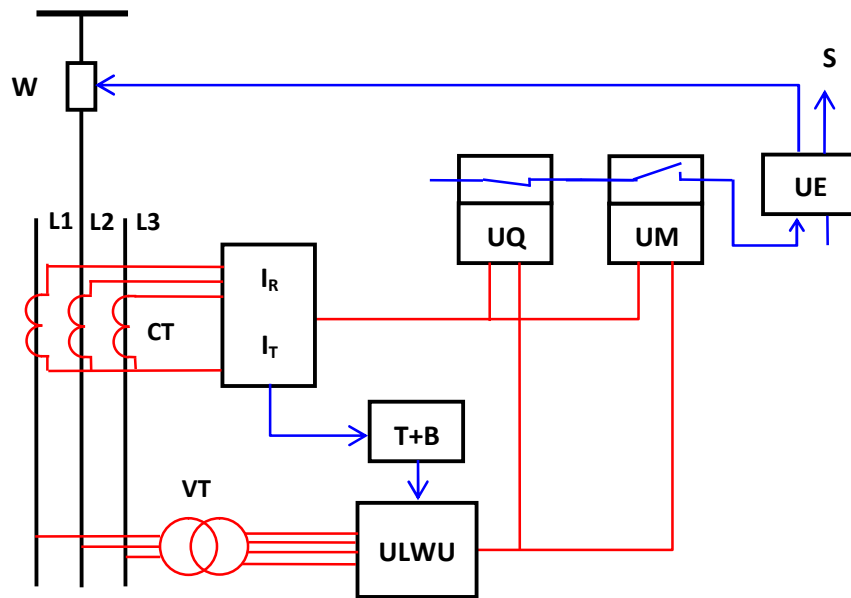

Fig. 8. Functional block diagram of the R1KZ4 relay; I_R , I_T , I_M – over-current sensing units, UM – measuring unit, UQ – directional-sensing element, T+B – timing and setting unit, ULWU – logical function-selection element, UE – output and tripping block.

Likewise, the output contact of the measuring unit (UM) caused to open for faults beyond this reach and will reclose after selected time lag for setting adjusted to the stage of the fault location. Therefore, for the short-circuit power flow towards the line and in case when the output contact of measuring unit (UM) is closed, the output block (UE) will cause to operate and clear the fault as a result.

The R1KZ4 relay does not require external supply for auxiliary circuits. It is provided by means of special designed saturated transformers which are energized (in case of the fault) from secondary CTs. Thus, for normal conditions of the line operation the R1KZ4 relay is in neutral (standstill) state.

For the faults behind the relay (short-circuit power direction is reversed i.e. - to busbars) the directional unit (UQ) will block however tripping of the breaker takes place as well but after so called final time (t_f) being set with coordinated delay time.

In case of the poly-phase faults the measuring (UM) and directional (UQ) units are provided with phase-to-phase voltage value of the faulted phases and with one line fault current respectively



THE DEVELOPMENT OF THE POTENTIAL AND ACADEMIC PROGRAMMES OF WROCLAW UNIVERSITY OF TECHNOLOGY

(e.g. at L1-L2 fault: U_{L12} and I_{L1}). For double phase-to-ground faults the additional (except I_R and/or I_T) ground over-current relay will cause to operate that usually provide quite sensitive and satisfactory protection. It makes the (UM) and (UQ) to measure the phase quantities (e. g. for L1-L2 short-circuit through the ground – U_{L1} and $(I_{L1} + 3kI_0)/2$, where $k = \frac{1}{3} \left(\frac{X_0}{X_1} - 1 \right)$ is a compensation factor). The relay setting is fixed (I_M).

Basic technical parameters

• rated voltage U_n	100V
• rated current I_n	5A
• regulation range of I_R and I_T	5 – 10A
• tripping of ground fault relay I_M	5A
• inherent delay time of the relay	0.08 – 0.1s
• directional sensitivity	1% U_N at $I=5A$
• minimum setting value for stage I	$2Z_I = 0.1\Omega$
• maximum setting value for stage III	$2Z_{III} = 0.1\Omega$
• internal phase shift of directional-sensing element	$(40 - 50)^\circ$ lead

2.1.2. Setting of the R1KZ4 relay

To select the proper operational characteristic of the relay (which is dependent on characteristic angle value of the line impedance to be protected) one has to adjust position of respective shunting clamps located at the left bottom corner of the relay face plate. The stage of impedance to be measured is adapted by setting of required resistance value (r) of the resistor and tapped (c) auxiliary transformer. Therefore, the regulation resistors are connected to bottom terminals of the relay and are setted according to so called dual system. Their values are labeled on the face plate. First group, marked as r_I , uses for the I zone (stage I) setting. Likewise – resistors r_{II} and r_{III} – for stage II and stage III respectively. To achieve more precise setting of the particular stage limit one has to use tapping (c – coefficient). Therefore, having selected primary impedance values of particular stages (X_I , R_I , X_{II} , R_{II} etc) to perform the relay setting it is necessary to calculate their equivalent values of r_I , r_{II} etc. They are derived from following formulas depending of the characteristic required:

a) for plain impedance relay

$$r = \frac{2}{c} \frac{n_i}{n_u} \sqrt{R^2 + X^2} \quad (2)$$

b) for mixed impedance relay

$$r = \frac{2}{c} \frac{n_i}{n_u} \cdot 1.05X \quad (3)$$



THE DEVELOPMENT OF THE POTENTIAL AND ACADEMIC PROGRAMMES OF WROCLAW UNIVERSITY OF TECHNOLOGY

c) for conductance relay

$$r = \frac{1}{c} \frac{n_i}{n_u} \cdot \left(R + \frac{X^2}{R} \right) \tag{4}$$

where: n_i, n_u – turn ratio of measuring current and voltage transformers providing the relay

2.1.3. Circuit for laboratory testing

Schematic diagram of the circuit for laboratory investigation of the R1KZ4 relay is presented in Fig 9.

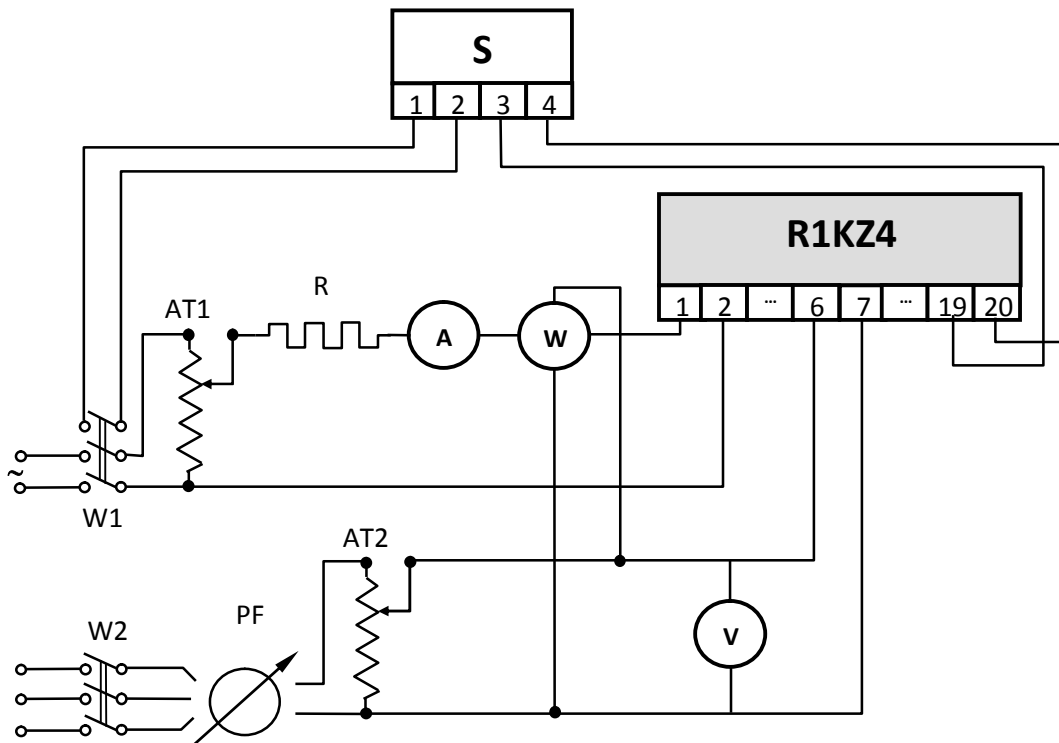

Fig 9. Schematic diagram of measuring circuit for testing R1KZ4 relay(A – ammeter, V – voltmeter, W – wattmeter, W1, W2 – switches, S – stop watch, AT1, AT2 – autotransformers, PF – phase shifter

Indicated (in this figure) connection of input voltage and current measuring circuits to terminal 1,2 and 6,7 of the relay is equivalent to phase-to-phase A-B (L1-L2) simulation.

Required values of current (I) and voltage (U_{L12}) are controlled by means of autotransformers AT1 and AT2 respectively. While, the phase shifter (PF) uses for setting the phase displacement between I and U_{L12} (output – zero – position of the PF is adjusted with the use of wattmeter (W)). As one can see to verify the relay performance no auxiliary energy source is needed.

2.1.4. Determination of the impedance circular characteristic

Before enter for testing one has to derive the relay setting basing on of following data (delivered by supervising person):



THE DEVELOPMENT OF THE POTENTIAL AND ACADEMIC PROGRAMMES OF WROCLAW UNIVERSITY OF TECHNOLOGY

- reactance and resistance value of the protected line,
- turn ratios of measuring voltage and current transformers applied,
- range of I, II and III stage (zone),
- time lag of particular stages.

Basing on careful consideration of the above mentioned data one has to:

- select proper characteristic of the measuring element,
- calculate the relay setting according to p. 2.2.2.

The circular characteristic is determined for the I zone (stage I), therefore, sliding contact of the timing unit (t_1) set to zero, and all others for $t=\infty$. Next, according to calculations adjust “r” values for particular stages.

First step is to make scalling of the phase shifter (PF). Therefore, using AT1 provide current value $I=I_n$, and by means of AT2 select the U_{AB} to be equal to half of its rated value ($U_{AB}=0,5U_n$). Next, by changing rotor position of the phase shifter make wattmeter measurement to be zero (it means that the phase shift (φ) between \underline{I} and \underline{U}_{AB} phasors is equal to $\pi/2$). For detecting lag or lead position one has to short-circuit the input current terminals of the wattmeter being fixed to zero. If the pointer tends to moves to the left it means that \underline{U}_{AB} leads current \underline{I} (inductive load), if reverse – it lags (capacitive load).

To derive particular points of the $Z_m=f(\varphi)$ characteristic one has to switch on the button switch (W1) and at $U_{AB}=0.5U_n$ adjust current (I) value for $2I_n$ that must be kept constant during measurements. Start the measure procedure at the phase shift equal to zero ($\varphi=0^0$) and follow it for each 10^0 for both leading and lagging conditions. Next decrease (using AT2) slowly and fluently U_{AB} value until the relay operates. Note this operational U_{rAB} value in Table 1. Having completed the measurements plot the $Z_r=f(\varphi)$ circle, where Z_r is calculated from formula (5):

$$Z_r = \frac{U_{rAB}}{2I} \tag{5}$$

Table 1. Results of measurements under derivation of impedance characteristic

Distance relay:					$I_n = \dots\dots\dots$
Type.....	No.....			$U_n = \dots\dots\dots$	
Lp	I	φ	U_r	Z_r	Comments
-	A	1^0	V	Ω	-
1					
2					
3					



THE DEVELOPMENT OF THE POTENTIAL AND ACADEMIC PROGRAMMES OF WROCLAW UNIVERSITY OF TECHNOLOGY

and compare it with theoretical one being drawn as well.

2.1.5. Determination of the time-impedance dependent characteristic

Before enter for measuring one has to:

- set the timing element (T) according to time lag for particular stages (zones),
- adjust the phase angle (using the phase shifter) for value equal to its of the line impedance,
- set up current to be $I=2I_n$ and hold this value constant under the measurements.

Start the measuring for $U_{AB}=0$. Next by switching on (W1) provide the current flow what results in the relay tripping. Record this tripping time value by the stop watch (S). Repeat this procedure however, for different U_{AB} value which must be increased gradually by 5V. Each measuring point should be calculated as the medium value time (t_{sr}) for three following measurements. The results set up in Table 2.

Table 2. Measuring results of time –impedance dependent characteristic

Distance relay:								
Type.....		No		$I_n =$		$U_n =$		
Lp	I	U	Z_m	3t	t_{sr}	Setting		
	A	V	Ω	s	s	stage	X	t
						-	Ω	s
1						I		
2						II		
3						III		
4						IV		

Basing on the obtained results plot the $t_{sr}=f(Z_m)$ curve, where Z_m is calculated according to eq. (5). Compare the measured characteristic with the theoretical (set up) one on the same diagram.

2.2. Microprocessor based distance relay

Solid state units provide greater flexibility, more adjustable characteristics, higher accuracy and range of setting as well as reduced size and hope, in a future lower costs. Besides, realization of different function such a control logic, event recording etc. The capability and flexibility inherent in microprocessor relays have increased the availability and utilization of distance units with

THE DEVELOPMENT OF THE POTENTIAL AND ACADEMIC PROGRAMMES OF WROCLAW UNIVERSITY OF TECHNOLOGY

quadrilateral characteristics. It makes the operating area of a distance element almost ideal. It is especially useful for ground faults that are often restricted.

2.2.1. Investigation procedure

However the microprocessor based distance relays offer tremendous variety of functions but the principle of operation is based on the same ideas as used in electromechanical relays. Therefore, the testing procedure is similar to that presented for the R1KZ4 relay.

For testing the distance relay will be selected by supervising person. The characteristic to be verified will be also recommended by him.

TASK No 8

ACCEPTANCE AND RELIABILITY COMPLIANCE TEST

AND SETTING OF GENERATOR PROTECTION

Concise manual

1. Introduction

Automated electrical power system (AEPS) is the science, skill and art of applying and setting protective devices (relays, fuses, microprocessor – based measuring and decisive systems) to provide operation with maximum sensitivity at the first sign of faults and undesirable conditions to minimize the potential catastrophic problems that can result in the power system. However, any operations under all permissible or tolerable conditions have to be avoided. Both failure to operate and incorrect operation can result in upset involving increased equipment damage, increased personnel hazards and possible long interruption of service. Therefore, all the AEPS-s have to meet requirements concerning both electrical power systems and power plants reliable operation as well as save conditions of work for servicing personnel. According to formal specifications the AEPS has to be undergone various testing procedures under operation. We distinguish here:

- **acceptance test** before involve the protection to service
- **routine test** for the protection being in operation. Its frequency depends on exploitation conditions (e.g. humidity contaminations, vibrations) and is in range of a half year to two years.
- **reliability compliance test** (current). It is simplified testing (e.g. once during a day or a week) to check for example operation of movable elements and/or continuity of communication and output signaling and tripping circuits.

The acceptance test consists in:

- a) inspection and control of mechanical state (assembling, fastening, moving parts freedom, screwing, state of casting, marking etc),
- b) investigation of current and voltage circuitry of the protections (continuity, proper selection as well as connecting and assembling of current and voltage measuring transformers),
- c) examination of scale of measuring as well as timing relays (elements), determination of selected (basic) points of operational characteristics (routine test) and adjustment of these elements,
- d) examination of reliable operation of the protections (continuity of output both control and acoustic or optical blocks),
- e) examination of communication parts for central signaling systems.

THE DEVELOPMENT OF THE POTENTIAL AND ACADEMIC PROGRAMMES OF WROCLAW UNIVERSITY OF TECHNOLOGY

On the basis of the investigated results respective reports should be made. They must include following data:

- description of the object being protected, supply system specification characteristics of the protection, testing method and list of metering instruments,
- rated data of the protected object as well as circuit breakers, measuring transformers and relaying devices,
- data necessary for the protection adjustment,
- tables with listed investigated results,
- results of functional tests,
- conclusions on state and performance of particular elements as well as the whole protection system with statement on permission for further application.

Procedure methods of testing as well as measuring instruments and systems should be selected the same as for the laboratory investigations provided the control-measuring sets are portable. However, it is necessary to provide conditions of the protection operation under real short circuits. Therefore, during the short circuit testing either respective currents in transient, in primary circuit must be provided by means of selected high power current transformers or the faults must be simulated.

2. Protection systems of synchronous generator

Protection requirements need to relate to the value of the generator protected. As such, these requirements for large units differ from those for smaller units. Besides, connection of a generator and its location in the power system can create site-specific hazard to the generator as well as the power system. Protective systems that need to be applied depend therefore on the types of generation placed in service and the manner in which they are connected to the power grid (direct and/or unit connected generators). Now combined Heat and Power (CHP) schemes are being installed to achieve greater fuel efficiency. The generators can be classified, in general, as bulk power generators (BPG) and distributed generators (DG).

BPG are typically above 20 MVA in size (usually are in the 100 MVA to 1200 MVA). They are synchronous machines being interconnected into the bulk power transmission system. These generators are often located in power plants that in turn are selected on the basis of factors such as for example proximity to fuel supply. Most of such generating plants are steam plants fueled by coal, oil, gas and uranium (hydro-driven generators are limited to availability of large-scale hydropower). BPG are usually connected to the power system through a high voltage switchyard located at the plant area or may tap into a bulk power transmission line, creating a three terminal line (smaller units). Distributed generators (DG) are made up of induction or synchronous machines. Induction generators (that are simply induction motors driven by a prime mover above synchronous speed) require a source



THE DEVELOPMENT OF THE POTENTIAL AND ACADEMIC PROGRAMMES OF WROCLAW UNIVERSITY OF TECHNOLOGY

of excitation, which is typically obtained from the power system to which it is connected. Different types of distributed generators (also with self-excitation) are powered from a variety of sources such as solar, biomass, wind, geothermal, urban waste as well as conventional fossil fuel. They size can vary from very small single-phase units at several kVA to units exceeding 100 MVA (large units are usually connected to a subtransmission system). Distributed generators connected to distribution system are usually of about (10-15) MVA in size.

However, independently on the generator type, protection requirements are similar (of course for smaller generators the protection is less sophisticated). Generating plant can be affected by a mix of mechanical and electrical conditions like:

- failure of winding insulation,
- prime mover failure,
- loss of excitation,
- under/over frequency,
- under/over voltage,
- overload,
- unbalanced loading.

Small power generator (around 10 kVA) located in lab represents model of turbogenerator of rated power from few to over a dozen of MVA direct connected to a common bus bar. It is wye-grounded through resistance. For such generators required protection package is as follows:

fundamental protection

- a) current differential protection (longitudinal) – against internal faults in primary and backup phase in the stator and associated areas,
- b) zero-sequence overcurrent protection – against ground faults in the stator and associated area,
- c) overcurrent protection with ac current source (to force leakage current in measuring circuit) – against single ground faults in the rotor (first ground on the field)
- d) 1-phase overcurrent definite time protection – against thermal overload of the stator.

backup protection

- e) overcurrent definite time voltage controlled protection – against uncleared system phase to phase faults,
- f) double-points ground faults in the rotor (second ground on the field),
- g) unbalanced loading,
- h) loss-of-field excitation,
- i) over voltage conditions (hydrogenerators),
- j) prime mover failure (motor operation of generator).

The laboratory generator model is equipped with protection mentioned above in a) to e) points.

THE DEVELOPMENT OF THE POTENTIAL AND ACADEMIC PROGRAMMES OF WROCLAW UNIVERSITY OF TECHNOLOGY

In general, the synchronous generators have to be properly coordinated with other power system protections and control devices. Therefore, both overexcitation and field underexcitation should be carefully controlled. The maximum and minimum excitation limiters should be set such that limiting action occurs before operation of the associated over and/or loss-of-field relaying (field forcing or damping). However, in modern solutions, when operating with the fast voltage regulator in the automatic model (AVR), the strength of the field is automatically and constantly changed, based on a feedback signal that reflects a system voltage level.

Typical connections for the protection of the model generator is shown in Fig 1.

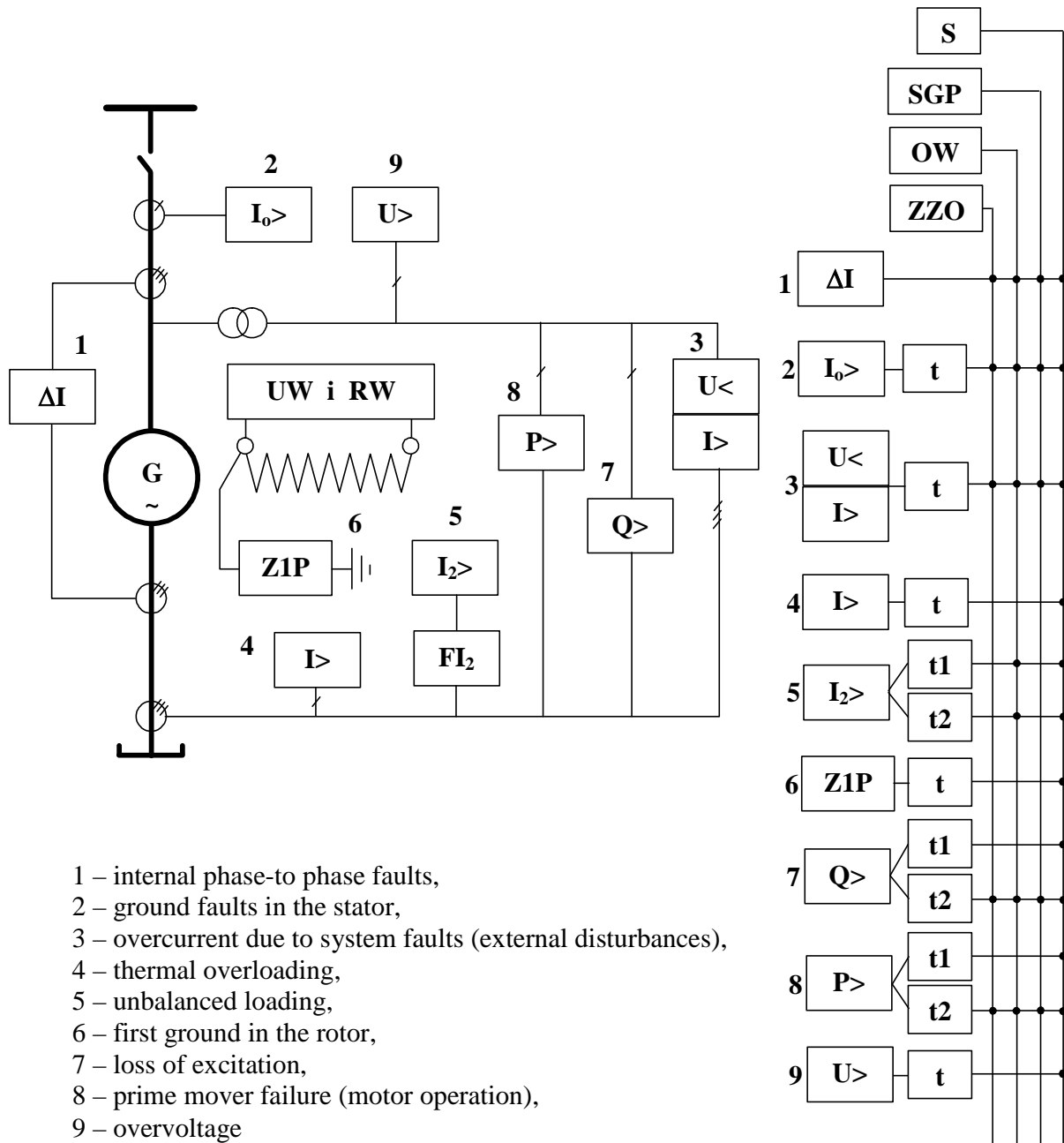

Fig. 1. Schematic of the protection for the synchronous generator model

3. Particular protection and its setting

3.1. Stabilized current differential protection (longitudinal)

Protection should be indicated by respective reliability of operation. However reliability has two aspects: dependability and security. Dependability indicates the ability of the protection system to perform correctly (with high sensitivity) when required, whereas security is its ability to avoid unnecessary operation during normal performance (e.g. residual current and voltage) and faults outside the designed zone of operation. Therefore, the current operating threshold (i_{ro}) is calculated from formula:

$$i_{ro} = k_b \frac{I_{ng}}{n_i} \quad (1)$$

where: I_{ng} – rated current value of generator,

n_i – turns ratio of current transformers,

k_b – safety factor (0.2 ÷ 0.4)

Value of stabilization coefficient k_b should be equal to 0.2 – 0.4. Differential protection provides immediate operation under internal phase-to phase faults tripping the generator breaker, tripping of the field and turbine and providing acoustic as well as optical alarms.

3.2. Stator ground-fault protection

Protection is operated by zero-sequence current value and in the laboratory model is energized from current transformer located in grounding conductor of neutral point of the generator. It should be insensitive to residual current due to unbalanced loading. The current operating threshold (i_{ro}) is equal:

$$i_{ro} = k_b \frac{I_{ng}}{n_i} \quad (2)$$

where: safety factor $k_b=0.5 \div 1$.

The protection provides similar immediate tripping as the differential protection.

3.3. Protection of single ground fault in the rotor

A single ground on the field does not cause any problem. A second ground, however causes a portion of the field winding to be shorted what can result, first of all, in damaging vibration and increased temperatures. Therefore, protective systems are applied to detect field ground and deteriorating field insulation. There are various types of field ground detection systems (often provided by the generator manufacturer). One such scheme connects the rotor DC circuit through a separate capacity to the auxiliary AC source. The capacity value can be selected from resonance conditions (for 50 Hz) with inductance of a relay. The relay detects any field leakage current to



THE DEVELOPMENT OF THE POTENTIAL AND ACADEMIC PROGRAMMES OF WROCLAW UNIVERSITY OF TECHNOLOGY

ground. It provides alarm with fixed time-delay trip to permit operator action or immediate tripping the generator breaker for turbogenerators with hydrogen cooling.

3.4. Overload protection

If temperature detectors are not available an overcurrent relay supplied by stator current (CT in one phase) may be applied. Its setting is selected for 10% acceptable thermal overloading of the stator. The recommended setting (i_r) is:

$$i_r = \frac{k_b}{k_p} \frac{I_{ng}}{n_i} \quad (3)$$

where: $k_b=1.05$ and release coefficient $k_p=0.9$.

Protection provides alarm with fixed time-delay trip ranged from 4s to 10s.

3.5. Back-up protection from harm caused by external faults

It provides back-up protection for external faults in elements of a network supplied by generator as well as for internal faults (phase – to phase) in the stator.

Current setting (i_r) is related to permissible maximum overload of generator ($I_{ov.max}$) and is fixed as follows:

$$i_r = \frac{k_b}{k_p} \frac{I_{ov.max}}{n_i} \quad (4)$$

where: $k_b=1.1 \div 1.2$,

$$k_p=0.9,$$

while, time delay adjustment (t): $t = t_{max} + 2\Delta t$, where:

t_{max} – maximum delay time of protection for feeders supplied from the generator busbar,

Δt – margin (0.4 ÷ 0.5 s)

To improve safety the protection sensitivity and make easier differentiation of faults from overloads it is voltage controlled. Under-voltage (u_r) threshold is equal:

$$u_r = \frac{k_b}{k_p} \frac{U_{min}}{n_u} \quad (5)$$

where: $U_{min} = 0.95U_{ng}$ (U_{ng} – rated voltage of generator),

$$k_b = 0.9,$$

$$k_p = 1.05 \div 1.2 \text{ (release coefficient),}$$

n_u – turn ratio of voltage transformer.

Protection tripping is the same like of the current differential protection.

THE DEVELOPMENT OF THE POTENTIAL AND ACADEMIC PROGRAMMES OF WROCLAW UNIVERSITY OF TECHNOLOGY

3.6. Field forcing

Generator fields are designed with short-term overload capability. This is important so that the field can be forced for short periods of time to provide high level of reactive power output to support the power system during disturbances that make voltage to decay. Field forcing can help the power system to go through such disturbances easily. Originally, particular resistors in the field circuit were respectively shunted by under-voltage relays for force required magnetic flux value. Under-voltage (u_r) threshold for relays is defined as:

$$u_r = k_b \frac{U_{ng}}{n_u} \quad (6)$$

where: $k_b = 0.6 \div 0.85$,

U_{ng} – rated voltage of generator

Currently, the field forcing is provide by means of automatic voltage regulator system (ARV).

4. Investigation of the generator protections

4.1. Laboratory test stand

Acceptance test of the generator protections is performed on the stand number V which is composed of a generator model, a table and an adjustment switch box number 1 respectively.

The generator model of type Gce64a is characterized by following rating:

$S_n=10$ kVA, $U_n=400$ V, $I_n=15.2$ A, $n=1500$ rev/min,

with field exciter: type DGM 8712, $P_n=600$ W, $U_w=40$ V.

The generator is driven by means of a DC shunt motor with automatic speed regulation both below and above rated velocity (n). On the stand table there are located following relays of particular protections:

- RRTG-6s (13P2) relay with stabilizing unit (13P1) – for differential protection,
- RI-3 (14P) relay – for stator ground fault protection,
- RIT-113 (11P) relay – for overload protection,
- RIT-313 (10P) relay and Rep-3 (1P, 2P, 3P) relays – for field forcing,
- Rep-3 (4P, 5P, 6P) under voltage relays – for field forcing.

Respective resistors and reactors unit for modeling of required as active as well as reactive power load of the generator are located inside the adjustment switch box No 1. Therefore, on a door plate of the switch there are located control buttons (to select required load), signaling lamps (indicating selected loading) and terminals marked as “R, S, T, 0” for short circuits modeling.

THE DEVELOPMENT OF THE POTENTIAL AND ACADEMIC PROGRAMMES OF WROCLAW UNIVERSITY OF TECHNOLOGY

Actuation of the generator

- first switch on power supply onto the stand No V. Red signaling lamp “220V” (on left hand side of the table plate) starts burning.
- next switch on control voltage pressing a green button “220V”. The remaining signaling red lamps will indicate it.
- follow pressing green buttons: “generator unit” (zespół prądowórczy) 380/220V and “generator load” (obciążenie generatora) to perform automatic starting of the generator.
- adjust rated voltage (400V) by means of a manually controlled resistor in the field circuit of the generator and setup next a rated frequency using respective buttons “up” (góra) and “down” (dół),
- select required load of the generator using buttons of the adjustment (switch box No 1).

Short circuits modeling (simulation)

- to simulate of both phase-to-phase and ground faults one has to use terminals “R, S, T, 0” located on the front part of the box No 1,
- the fault location (internal, external) is selected by means of the button on the left hand side (of the table plate). While the external fault distance is able to be fixed using respective change-over switch (also located on the left side),
- ground fault on the field is performed in turn when the “W-Z” short-circuited terminals are at the right side of the table plate.

4.2. Goal and range of the test

The goal is to acquaint student with range and way of the acceptance test of the generator protections for industrial power plant.

The test range includes:

- 1) Calculation of the generator protection setting (according to technical data delivered by supervising person),
- 2) Respective setting of the protections,
- 3) Investigation of the differential protection unit. Correctness of the secondary circuits connection is performed basing on currents measurement (in protection circuits as indicated in Fig 2) for simulated as internal as well as external faults. One has to employ respective vector diagrams of currents in longitudinal conductors at both sides of the differential bridge,
- 4) Investigation of the protections performance (functional test). Examination of reliable operation during various faults and estimation of the influence of the field forcing on operational characteristics of the selected protections,
- 5) Data handling and preparation of the respective report according to principles mentioned in chapter 1.



THE DEVELOPMENT OF THE POTENTIAL AND ACADEMIC PROGRAMMES OF WROCLAW UNIVERSITY OF TECHNOLOGY

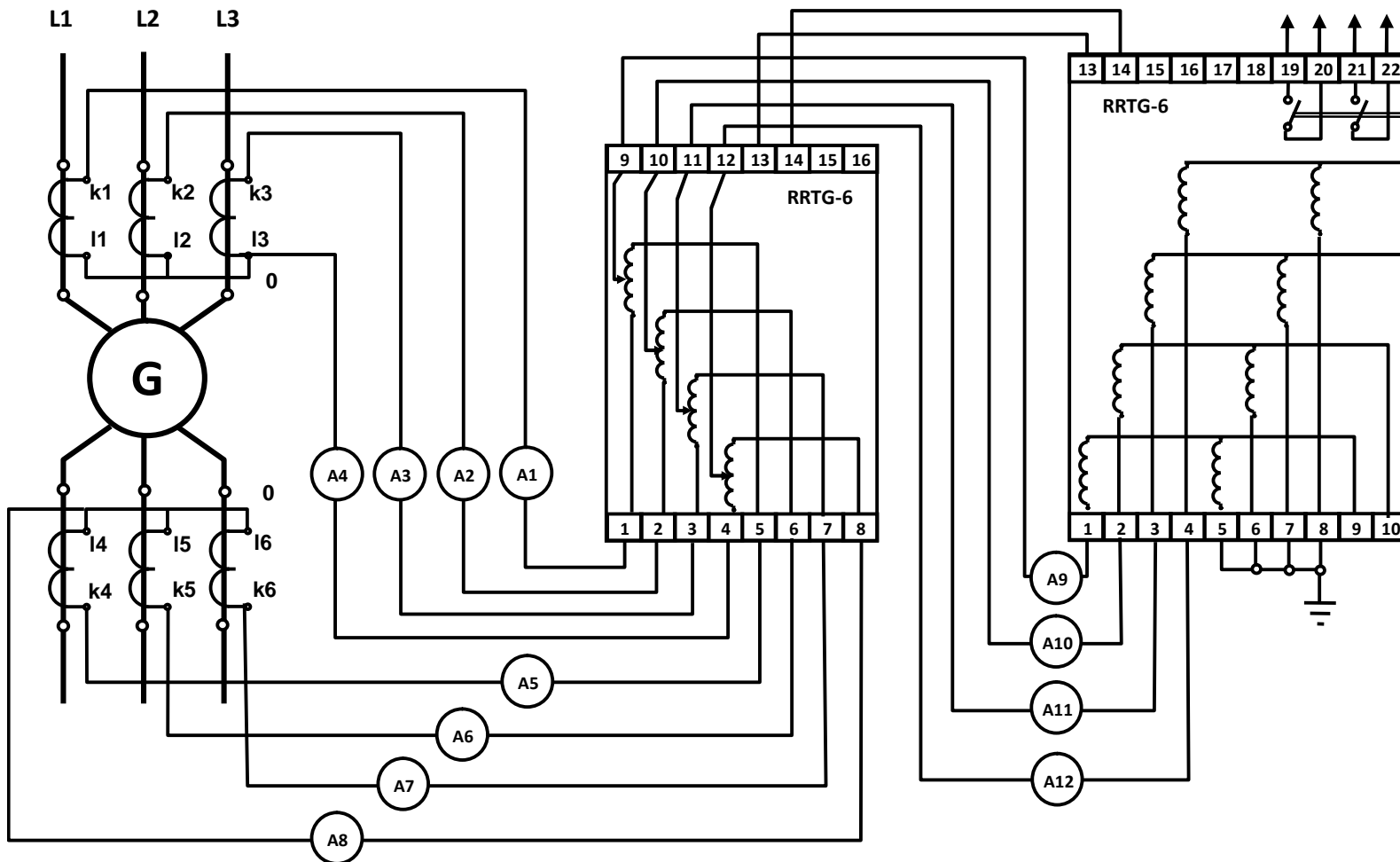

Fig. 2. Circuit diagram of the differential protection of RRTG-6 type of the generator